

**DRAFT RED HERRING PROSPECTUS**

December 5, 2018

Please read Section 32 of the Companies Act, 2013

(This Draft Red Herring Prospectus will be updated upon filing with the RoC)

**Book Built Offer**



**UNIPARTS INDIA LIMITED**

Our Company was incorporated as "Uniparts India Limited" under the Companies Act, 1956 at Delhi, pursuant to a certificate of incorporation dated September 26, 1994 issued by the Registrar of Companies, National Capital Territory of Delhi and Haryana at Delhi ("RoC"). Our Company received a certificate of commencement of business on September 7, 1998 from the RoC. For details of change in the Registered Office, see "History and Certain Corporate Matters - Changes in the Registered Office" on page 136.

**Registered Office:** Griplw House, Block - 5, Sector C 6 & 7, Vasant Kunj, New Delhi 110 070, India; **Tel:** +91 11 2613 7979

**Corporate Office:** Ground Floor, SB Tower, Plot 1A/1, Sector 16 A, Film City, Noida 201 301, India; **Tel:** +91 120 458 1400

**Contact Person:** Mukesh Kumar, Company Secretary, Compliance Officer and Associate Vice President - Legal; **Tel:** +91 120 458 1400; **E-mail:** compliance.officer@unipartsgroup.com

**Website:** www.unipartsgroup.com; **Corporate Identity Number:** U74899DL1994PLC061753

**OUR PROMOTERS: GURDEEP SONI AND PARAMJIT SINGH SONI**

**INITIAL PUBLIC OFFERING OF [●] EQUITY SHARES OF FACE VALUE OF ₹ 10 EACH ("EQUITY SHARES") OF UNIPARTS INDIA LIMITED ("OUR COMPANY" OR THE "ISSUER") FOR CASH AT A PRICE OF ₹ [●] PER EQUITY SHARE ("OFFER PRICE") AGGREGATING UP TO ₹ [●] MILLION, COMPRISING A FRESH ISSUE OF [●] EQUITY SHARES AGGREGATING UP TO ₹ 1,000 MILLION ("FRESH ISSUE") AND AN OFFER FOR SALE OF 13,060,770 EQUITY SHARES AGGREGATING UP TO ₹ [●] MILLION, COMPRISING 2,154,192 EQUITY SHARES BY AMBADEVI MAURITIUS HOLDING LIMITED ("AMBADEVI") AGGREGATING UP TO ₹ [●] MILLION AND 7,180,642 EQUITY SHARES BY ASHOKA INVESTMENT HOLDINGS LIMITED ("ASHOKA") AGGREGATING UP TO ₹ [●] MILLION, ("AMBADEVI" AND "ASHOKA" ARE TOGETHER REFERRED TO AS THE "INVESTOR SELLING SHAREHOLDERS") AND 177,378 EQUITY SHARES BY ANDREW WARREN CODE AGGREGATING UP TO ₹ [●] MILLION AND 16,366 EQUITY SHARES BY BRADLEY LORENZ MILLER AGGREGATING UP TO ₹ [●] MILLION AND 5,010 EQUITY SHARES BY CRAIG A JOHNSON AGGREGATING UP TO ₹ [●] MILLION AND 57,420 EQUITY SHARES BY DENNIS FRANCIS DEDECKER AGGREGATING UP TO ₹ [●] MILLION AND 8,340 EQUITY SHARES BY DIANA LYNN CRAIG AGGREGATING UP TO ₹ [●] MILLION AND 177,378 EQUITY SHARES BY JAMES NORMAN HALLENE AGGREGATING UP TO ₹ [●] MILLION AND 1,444,280 EQUITY SHARES BY KEVIN JOHN CODE AGGREGATING UP TO ₹ [●] MILLION AND 7,710 EQUITY SHARES BY MARC CHRISTOPHER DORAU AGGREGATING UP TO ₹ [●] MILLION AND 20,870 EQUITY SHARES BY MARK LOUIS DAWSON AGGREGATING UP TO ₹ [●] MILLION AND 10,440 EQUITY SHARES BY MARY LOUISE ARP AGGREGATING UP TO ₹ [●] MILLION AND 1,444,280 EQUITY SHARES BY MEHER SONI\* AGGREGATING UP TO ₹ [●] MILLION AND 41,730 EQUITY SHARES BY MELVIN KEITH GIBBS AGGREGATING UP TO ₹ [●] MILLION AND 826 EQUITY SHARES BY MISTY MARIE GARCIA AGGREGATING UP TO ₹ [●] MILLION AND 1,534,548 EQUITY SHARES BY PAMELA SONI\* AGGREGATING UP TO ₹ [●] MILLION AND 24,706 EQUITY SHARES BY WALTER JAMES GRUBER AGGREGATING UP TO ₹ [●] MILLION AND 21,556 EQUITY SHARES BY WENDY REICHAARD HAMMEN AGGREGATING UP TO ₹ [●] MILLION (TOGETHER, THE "INDIVIDUAL SELLING SHAREHOLDERS"), (THE INDIVIDUAL SELLING SHAREHOLDERS, AND THE INVESTOR SELLING SHAREHOLDERS ARE COLLECTIVELY, THE "SELLING SHAREHOLDERS") (THE "OFFER FOR SALE", AND TOGETHER WITH THE FRESH ISSUE, THE "OFFER"). THE OFFER WILL CONSTITUTE [●]% OF OUR POST-OFFER PAID-UP EQUITY SHARE CAPITAL.**

**THE FACE VALUE OF EACH EQUITY SHARE IS ₹10. THE OFFER PRICE IS [●] TIMES THE FACE VALUE OF THE EQUITY SHARES. THE PRICE BAND AND THE MINIMUM BID LOT WILL BE DECIDED BY OUR COMPANY AND THE INVESTOR SELLING SHAREHOLDERS IN CONSULTATION WITH THE BRLMS AND WILL BE ADVERTISED IN [●] EDITIONS OF [●] (A WIDELY CIRCULATED ENGLISH NATIONAL DAILY NEWSPAPER) AND [●] EDITIONS OF [●] (A WIDELY CIRCULATED HINDI NATIONAL DAILY NEWSPAPER, HINDI ALSO BEING THE REGIONAL LANGUAGE OF NEW DELHI WHERE OUR REGISTERED OFFICE IS LOCATED), AT LEAST TWO WORKING DAYS PRIOR TO THE BID/OFFER OPENING DATE AND SHALL BE MADE AVAILABLE TO THE BSE LIMITED ("BSE") AND THE NATIONAL STOCK EXCHANGE OF INDIA LIMITED ("NSE"), TOGETHER WITH BSE, THE "STOCK EXCHANGES") FOR UPLOADING ON THEIR RESPECTIVE WEBSITES.**

In case of any revision in the Price Band, the Bid/ Offer Period will be extended by at least three additional Working Days after such revision in the Price Band, subject to the Bid/ Offer Period not exceeding 10 Working Days. In cases of force majeure, banking strike or similar circumstances, our Company may, for reasons to be recorded in writing, extend the Bid / Offer Period for a minimum of three Working Days, subject to the Bid/ Offer Period not exceeding 10 Working Days. Any revision in the Price Band and the revised Bid/ Offer Period, if applicable, shall be widely disseminated by notification to the Stock Exchanges, by issuing a press release, and also by indicating the change on the respective websites of the BRLMs and at the terminals of the Syndicate Members and by intimation to Designated Intermediaries.

This Offer is being made in terms of Rule 19(2)(b) of the Securities Contracts (Regulation) Rules, 1957, as amended ("SCRR") read with Regulation 31 of the Securities and Exchange Board of India (Issue of Capital and Disclosure Requirements) Regulations, 2018, as amended (the "SEBI ICDR Regulations"). This Offer is being made through the Book Building Process in accordance with Regulation 6(1) of the SEBI ICDR Regulations wherein not more than 50% of the Offer shall be available for allocation on a proportionate basis to Qualified Institutional Buyers ("QIBs") (the "QIB Portion"), provided that our Company and the Investor Selling Shareholders in consultation with the BRLMs may allocate up to 60% of the QIB Portion to Anchor Investors on a discretionary basis. One-third of the Anchor Investor Portion shall be reserved for domestic Mutual Funds, subject to valid Bids being received from the domestic Mutual Funds at or above the Anchor Investor Allocation Price. 5% of the QIB Portion (excluding the Anchor Investor Portion) shall be available for allocation on a proportionate basis to Mutual Funds only, and the remainder of the QIB Portion shall be available for allocation on a proportionate basis to all QIB Bidders (other than Anchor Investors), including Mutual Funds, subject to valid Bids being received at or above the Offer Price. Further, not less than 15% of the Offer shall be available for allocation on a proportionate basis to Non-Institutional Bidders and not less than 35% of the Offer shall be available for allocation to Retail Individual Bidders in accordance with the SEBI ICDR Regulations, subject to valid Bids being received from them at or above the Offer Price. All Bidders, other than Anchor Investors, are mandatorily required to participate in the Offer through the Application Supported by Blocked Amount ("ASBA") process by providing details of their respective bank accounts which will be blocked by the Self Certified Syndicate Banks ("SCSBs"). Anchor Investors are not permitted to participate in the Anchor Investor Portion through the ASBA Process. For details, see "Offer Procedure" beginning on page 277.

**RISKS IN RELATION TO THE FIRST OFFER**

This being the first public offer of our Company, there has been no formal market for the Equity Shares of our Company. The face value of the Equity Shares is ₹ 10 each. The Floor Price, Cap Price and Offer Price as determined and justified by our Company and the Investor Selling Shareholders, in consultation with the BRLMs, in accordance with the SEBI ICDR Regulations and on the basis of the assessment of market demand for the Equity Shares by way of the Book Building Process, as stated under "Basis for Offer Price" beginning on page 82 should not be taken to be indicative of the market price of the Equity Shares after the Equity Shares are listed. No assurance can be given regarding an active and/or sustained trading in the Equity Shares nor regarding the price at which the Equity Shares will be traded after listing.

**GENERAL RISK**

Investments in equity and equity-related securities involve a degree of risk and investors should not invest any funds in the Offer unless they can afford to take the risk of losing their investment. Investors are advised to read the risk factors carefully before taking an investment decision in the Offer. For taking an investment decision, investors must rely on their own examination of our Company and the Offer, including the risks involved. The Equity Shares in the Offer have not been recommended or approved by the Securities and Exchange Board of India ("SEBI"), nor does SEBI guarantee the accuracy or adequacy of the contents of this Draft Red Herring Prospectus. Specific attention of the investors is invited to "Risk Factors" beginning on page 21.

**ISSUER'S AND SELLING SHAREHOLDERS' ABSOLUTE RESPONSIBILITY**

Our Company, having made all reasonable inquiries, accepts responsibility for and confirms that this Draft Red Herring Prospectus contains all information with regard to our Company and the Offer, which is material in the context of the Offer, that the information contained in this Draft Red Herring Prospectus is true and correct in all material aspects and is not misleading in any material respect, that the opinions and intentions expressed herein are honestly held and that there are no other facts, the omission of which makes this Draft Red Herring Prospectus as a whole or any of such information or the expression of any such opinions or intentions misleading in any material respect. Each of the Selling Shareholders, severally and not jointly, accepts responsibility for and confirms only the statements made or confirmed by such Selling Shareholder in this Draft Red Herring Prospectus to the extent of information specifically pertaining to itself and its portion of the Equity Shares offered in the Offer for Sale and assume responsibility that such statements are true and correct in all material respects and not misleading in any material respect. The Investor Selling Shareholders assumes no responsibility for any other statements, including, *inter alia*, any of the statements made by or relating to our Company or its business or by any other person in this Draft Red Herring Prospectus.

**LISTING**

The Equity Shares offered through the Red Herring Prospectus are proposed to be listed on the Stock Exchanges. Our Company has received "in-principle" approvals from the BSE and the NSE for the listing of the Equity Shares pursuant to letters dated [●] and [●], respectively. For the purposes of the Offer, the Designated Stock Exchange shall be [●]. A copy of the Red Herring Prospectus and the Prospectus shall be delivered for registration to the RoC in accordance with Section 26(4) of the Companies Act, 2013. For details of the material contracts and documents available for inspection from the date of the Red Herring Prospectus until the Bid/ Offer Closing Date, see "Material Contracts and Documents for Inspection" beginning on page 292.

**BOOK RUNNING LEAD MANAGERS**

**REGISTRAR TO THE OFFER**

<p><b>Axis Capital Limited</b> Axis House, Level 1 C-2 Wadia International Centre P. B. Marg, Worli Mumbai 400 025 India Tel: +91 22 4325 2183 E-mail: ul.ipo@axiscap.in Investor Grievance E-mail: complaints@axiscap.in Website: www.axiscapital.co.in Contact Person: Bhumika Gangar SEBI Registration No.: INM000012029</p>	<p><b>Motilal Oswal Investment Advisors Limited</b> Motilal Oswal Tower Rahimtullah Sayani Road Opposite Parel ST Depot, Prabhadevi Mumbai 400 025 India Tel: +91 22 3846 4200 E-mail: uniparts.ipo@motilaloswal.com Investor grievance E-mail: moiapredressal@motilaloswal.com Website: www.motilaloswalgroup.com Contact Person: Keyur Desai / Kristina Dias SEBI Registration No.: INM000011005</p>	<p><b>SBI Capital Markets Limited</b> 202, Market Tower 'E' Cuffe Parade Mumbai 400 005 India Tel: +91 22 2217 8300 E-mail: uniparts.ipo@sbicaps.com Investor Grievance E-mail: investor.relations@sbicaps.com Website: www.sbicaps.com Contact Person: Karan Savardekar/ Janardhan Wagle SEBI Registration No.: INM000003531</p>	<p><b>Link Intime India Private Limited</b> C-101, 1<sup>st</sup> Floor, 247 Park, L.B.S Marg, Vikhroli (West) Mumbai 400 083 India Tel: +91 22 4918 6200 Email: uniparts.ipo@linkintime.co.in Investor Grievance E-mail: uniparts.ipo@linkintime.co.in Website: www.linkintime.co.in Contact Person: Shanti Gopalkrishnan SEBI Registration No.: INR000004058</p>

**BID/OFFER PROGRAMME**

<b>BID/OFFER OPENS ON</b>	[●]***
<b>BID/OFFER CLOSES ON</b>	[●]****

\* The Individual Selling Shareholders, Meher Soni and Pamela Soni, form part of our Promoter Group.  
 \*\* Our Company and the Investor Selling Shareholders may, in consultation with the BRLMs, consider participation by Anchor Investors in accordance with the SEBI ICDR Regulations. The Anchor Investor Bid/Offer Period shall be one Working Day prior to the Bid/Offer Opening Date.  
 \*\*\* Our Company and the Investor Selling Shareholders may, in consultation with the BRLMs, consider closing the Bid/Offer Period for QIBs one Working Day prior to the Bid/Offer Closing Date in accordance with the SEBI ICDR Regulations.

*(This page is intentionally left blank)*

## TABLE OF CONTENTS

<b>SECTION I: GENERAL</b> .....	<b>1</b>
DEFINITIONS AND ABBREVIATIONS .....	1
PRESENTATION OF FINANCIAL, INDUSTRY AND MARKET DATA .....	14
FORWARD-LOOKING STATEMENTS .....	16
SUMMARY OF THE OFFER DOCUMENT .....	17
<b>SECTION II: RISK FACTORS</b> .....	<b>21</b>
<b>SECTION III: INTRODUCTION</b> .....	<b>50</b>
THE OFFER .....	50
SUMMARY OF FINANCIAL INFORMATION .....	52
GENERAL INFORMATION .....	57
CAPITAL STRUCTURE.....	64
OBJECTS OF THE OFFER .....	76
BASIS FOR OFFER PRICE .....	82
STATEMENT OF SPECIAL TAX BENEFITS.....	84
<b>SECTION IV: ABOUT OUR COMPANY</b> .....	<b>87</b>
INDUSTRY OVERVIEW .....	87
OUR BUSINESS .....	113
KEY REGULATIONS AND POLICIES IN INDIA .....	133
HISTORY AND CERTAIN CORPORATE MATTERS .....	136
OUR MANAGEMENT .....	143
OUR PROMOTERS AND PROMOTER GROUP .....	158
DIVIDEND POLICY .....	161
<b>SECTION V: FINANCIAL INFORMATION</b> .....	<b>162</b>
FINANCIAL STATEMENTS .....	162
OTHER FINANCIAL INFORMATION .....	236
CAPITALISATION STATEMENT .....	237
FINANCIAL INDEBTEDNESS.....	238
MANAGEMENT'S DISCUSSION AND ANALYSIS OF FINANCIAL CONDITION AND RESULTS OF OPERATIONS.....	241
<b>SECTION VI: LEGAL AND OTHER INFORMATION</b> .....	<b>254</b>
OUTSTANDING LITIGATION AND MATERIAL DEVELOPMENTS .....	254
GOVERNMENT AND OTHER APPROVALS .....	257
OUR GROUP COMPANY .....	259
OTHER REGULATORY AND STATUTORY DISCLOSURES .....	261
<b>SECTION VII: OFFER INFORMATION</b> .....	<b>271</b>
TERMS OF THE OFFER .....	271
OFFER STRUCTURE.....	275
OFFER PROCEDURE .....	277
RESTRICTIONS ON FOREIGN OWNERSHIP OF INDIAN SECURITIES.....	286
<b>SECTION VIII: MAIN PROVISIONS OF ARTICLES OF ASSOCIATION</b> .....	<b>287</b>
<b>SECTION IX: OTHER INFORMATION</b> .....	<b>292</b>
MATERIAL CONTRACTS AND DOCUMENTS FOR INSPECTION .....	292
DECLARATION .....	295

## SECTION I: GENERAL

### DEFINITIONS AND ABBREVIATIONS

*This Draft Red Herring Prospectus uses certain definitions and abbreviations which, unless the context otherwise indicates or implies, or unless otherwise specified, shall have the meaning as provided below. References to any legislation, act, regulation, rules, guidelines or our Articles of Association, Memorandum of Association, policies shall be to such legislation, act or regulation, as amended from time to time and any reference to a statutory provision shall include any subordinate legislation made from time to time under that provision.*

*The words and expressions used in this Draft Red Herring Prospectus but not defined herein, shall have, to the extent applicable, the meanings ascribed to such terms under the Companies Act, the SEBI ICDR Regulations, the SCRA, the Depositories Act or the rules and regulations made thereunder.*

*Notwithstanding the foregoing, terms used in “Statement of Special Tax Benefits”, “Financial Information”, “Main Provisions of Articles of Association”, “Outstanding Litigation and Material Developments” and “Key Regulations and Policies in India” beginning on pages 84, 162, 287, 254 and 133, respectively, shall have the meaning ascribed to such terms in these respective sections.*

#### General Terms

Term	Description
“our Company”, “the Company” or “the Issuer”	Uniparts India Limited, a company incorporated under the Companies Act, 1956, and having its registered office at Gripwel House, Block – 5, Sector C 6 & 7, Vasant Kunj, New Delhi 110 070, India
“we”, “us”, or “our”	Unless the context otherwise indicates or implies, our Company together with its Subsidiaries, on a consolidated basis

#### Company Related Terms

Term	Description
Ambadevi	Ambadevi Mauritius Holding Limited
“Articles of Association” or “AoA”	Articles of Association of our Company, as amended
Ashoka	Ashoka Investment Holdings Limited
Audit Committee	The audit committee of our Board, as described in “Our Management” beginning on page 143
“Auditors” or “Statutory Auditors”	Statutory auditors of our Company, namely, Rakesh Banwari & Co., Chartered Accountants
“Board” or “Board of Directors”	Board of directors of our Company or a duly constituted committee thereof
Chief Financial Officer	Chief financial officer of our Company
Company Letter Agreement	The Letter Agreement dated September 22, 2014, entered into by and amongst our Promoters, Ambadevi, Ashoka and our Company.
Corporate Office	The corporate office of our Company located at Ground Floor, SB Tower, Plot 1A/1, Sector 16 A, Film City, Noida 201 301, India
Corporate Social Responsibility Committee	The corporate social responsibility committee of our Board, as described in “Our Management” beginning on page 143
Director(s)	Director(s) on the Board
Equity Shares	Equity shares of our Company of face value of ₹10 each
ESOP	Employee Stock Option Plan
ESOP 2007	Uniparts Employee Stock Option Plan – 2007, as amended from time to time
Executive Directors	Executive Directors of our Company
GFPL	The wholly-owned subsidiary of our Company, namely Gripwel Fasteners Private Limited

<b>Term</b>	<b>Description</b>
Group Company	Companies (other than our Promoters and Subsidiaries) with which there were related party transactions as disclosed in the Restated Financial Statements as covered under the applicable accounting standards, and as disclosed in “ <i>Our Group Company</i> ” beginning on page 259
Individual Selling Shareholders	Together, Andrew Warren Code, Bradley Lorenz Miller, Craig A Johnson, Dennis Francis DeDecker, Diana Lynn Craig, James Norman Hallene, Kevin John Code, Marc Christopher Dorau, Mark Louis Dawson, Mary Louise Arp, Meher Soni, Melvin Keith Gibbs, Misty Marie Garcia, Pamela Soni, Walter James Gruber and Wendy Reichard Hammen
Investor Selling Shareholders	Together, Ashoka and Ambadevi
Independent Directors	Independent Directors on our Board, and eligible to be appointed as independent directors under the provisions of the Companies Act, 2013 and the SEBI Listing Regulations. For details of the Independent Directors, see “ <i>Our Management</i> ” beginning on page 143
Investment Agreement	Investment Agreement dated September 13, 2007, entered into by and amongst our Promoters, Ambadevi, Ashoka and our Company. For details, see “ <i>History and Certain Corporate Matters</i> ” beginning on page 136
Kavee	Uniparts Kavee B.V., our Company’s erstwhile joint venture with Kramp
Key Managerial Personnel	Key managerial personnel of our Company in terms of Regulation 2(1)(bb) of the SEBI ICDR Regulations as disclosed in “ <i>Our Management</i> ” beginning on page 143
Kramp	Kramp Groep B.V., our erstwhile joint venture partner
“Memorandum of Association” or “MoA”	Memorandum of Association of our Company, as amended
Nomination and Remuneration Committee	The nomination and remuneration committee of our Board, as described in “ <i>Our Management</i> ” beginning on page 143
Nominee Director	Nominee Director of our Company
Olsen Investors	Collectively, Kevin John Code, Dennis Francis DeDecker, Andrew Warren Code, James Norman Hallene, Mark Louis Dawson, Melvin Keith Gibbs, Marc Christopher Dorau, Bradley Lorenz Miller, Walter James Gruber, Mary Louise Arp, Diana Lynn Craig, Wendy Reichard Hammen, Craig A Johnson and Misty Marie Garcia
Promoter Group	The persons and entities constituting the promoter group of our Company in terms of Regulation 2(1)(pp) of the SEBI ICDR Regulations, as disclosed in “ <i>Our Promoters and Promoter Group</i> ” beginning on page 158
Promoters Letter Agreement	The Letter Agreement dated September 22, 2014, entered into by and amongst our Promoters, Ambadevi, Ashoka and our Company.
Promoters	The promoters of our Company, namely, Gurdeep Soni and Paramjit Singh Soni
Registered Office	The registered office of our Company located at Gripwel House, Block – 5, Sector C 6 & 7, Vasant Kunj, New Delhi 110 070, India
“Registrar of Companies” or “RoC”	Registrar of Companies, National Capital Territory of Delhi and Haryana at Delhi
Restated Financial Statements	Restated consolidated financial statements of our Company as at and for the six month period ended September 30, 2018 and for the Fiscals ended March 31, 2018, 2017 and 2016 (prepared in accordance with Ind AS read with Section 133 of the Companies Act, 2013) which comprises the restated Ind AS consolidated statement of assets and liabilities, the restated Ind AS consolidated statement of profit and loss and the restated Ind AS consolidated statement of cash flows and notes thereto
Selling Shareholders	Together, the Individual Selling Shareholders and the Investor Selling Shareholders
SHA	Shareholders’ agreement dated September 25, 2007, entered into by and amongst our Promoters, Ambadevi, Ashoka and our Company, as amended by agreements dated September 7, 2010 and February 18, 2013 read along with the deed of accession dated May 31, 2012 by which Karan Soni became a party to the said shareholders’ agreement dated September 25, 2007 and two separate deeds of accession, each dated July 4,

<b>Term</b>	<b>Description</b>
	2012, by which Meher Soni became a party to the said shareholders' agreement dated September 25, 2007, a supplemental deed dated January 30, 2014 to the said shareholder's agreement dated September 25, 2007 amongst our Promoters, Ambadevi, Ashoka, Karan Soni, Meher Soni and our Company (together, the " <b>SHA Parties</b> "), and an amendment and termination agreement dated December 3, 2018 entered into between SHA Parties. For details, see " <i>History and Certain Corporate Matters</i> " beginning on page 136
Shareholders	Equity shareholders of our Company, from time to time
SKG	The Group Company of our Company, namely, SKG Engineering Private Limited
Stakeholders' Relationship Committee	The stakeholders' relationship committee of our Board, as described in " <i>Our Management</i> " beginning on page 143
Subsidiaries	Subsidiaries of our Company, namely, GFPL, UUL, UEBV, UIG and UOI
UEBV	The wholly-owned subsidiary of our Company, namely, Uniparts Europe B.V.
UIG	The wholly-owned subsidiary of our Company, namely, Uniparts India GmbH
Uniparts Group	The Company along with its Subsidiaries
UOI	The wholly-owned subsidiary of UUL, namely, Uniparts Olsen Inc.
UUL	The wholly-owned subsidiary of our Company, namely, Uniparts USA Limited

#### **Offer Related Terms**

<b>Term</b>	<b>Description</b>
Acknowledgement Slip	The slip or document issued by a Designated Intermediary to a Bidder as proof of registration of the Bid cum Application Form
"Allot", "Allotment" or "Allotted"	Unless the context otherwise requires, allotment of Equity Shares pursuant to the Fresh Issue and transfer of Equity Shares offered by the Selling Shareholders pursuant to the Offer for Sale to the successful Bidders
Allotment Advice	Note or advice or intimation of Allotment sent to the Bidders who have been or are to be Allotted the Equity Shares after the Basis of Allotment has been approved by the Designated Stock Exchange
Allottee	A successful Bidder to whom the Equity Shares are Allotted
Anchor Investor	A Qualified Institutional Buyer, applying under the Anchor Investor Portion in accordance with the requirements specified in the SEBI ICDR Regulations and the Red Herring Prospectus
Anchor Investor Allocation Price	The price at which Equity Shares will be allocated to Anchor Investors in terms of the Red Herring Prospectus, which will be decided by our Company and the Investor Selling Shareholders, in consultation with the BRLMs during the Anchor Investor Bid/Offer Period
Anchor Investor Application Form	The form used by an Anchor Investor to make a Bid in the Anchor Investor Portion and which will be considered as an application for Allotment in terms of the Red Herring Prospectus and Prospectus
Anchor Investor Bid/Offer Period	The day, being one Working Day prior to the Bid/Offer Opening Date, on which Bids by Anchor Investors shall be submitted, prior to and after which the BRLMs will not accept any bids from Anchor investors, and allocation to Anchor Investors shall be completed
Anchor Investor Offer Price	Final price at which the Equity Shares will be issued and Allotted to Anchor Investors in terms of the Red Herring Prospectus and the Prospectus, which price will be equal to or higher than the Offer Price but not higher than the Cap Price. The Anchor Investor Offer Price will be decided by our Company and the Investor Selling Shareholders, in consultation with the BRLMs

<b>Term</b>	<b>Description</b>
Anchor Investor Portion	Up to 60% of the QIB Portion which may be allocated by our Company and the Investor Selling Shareholders in consultation with the BRLMs, to Anchor Investors on a discretionary basis, in accordance with the SEBI ICDR Regulations.  One-third of the Anchor Investor Portion shall be reserved for domestic Mutual Funds, subject to valid Bids being received from domestic Mutual Funds at or above the Anchor Investor Allocation Price
Application Supported by Blocked Amount or ASBA	An application, whether physical or electronic, used by ASBA Bidders to make a Bid and authorize an SCSB to block the Bid Amount in the ASBA Account
ASBA Account	A bank account maintained with an SCSB and specified in the ASBA Form submitted by Bidders for blocking the Bid Amount mentioned in the ASBA Form
ASBA Bidders	All Bidders except Anchor Investors
ASBA Form	An application form, whether physical or electronic, used by ASBA Bidders which will be considered as the application for Allotment in terms of the Red Herring Prospectus and the Prospectus
Axis	Axis Capital Limited
Banker(s) to the Offer	Collectively, the Escrow Collection Bank(s), Refund Bank(s) and Public Offer Account Bank(s)
Basis of Allotment	Basis on which Equity Shares will be Allotted to successful Bidders under the Offer, as described in “Offer Procedure” beginning on page 277
Bid	An indication to make an offer during the Bid/Offer Period by an ASBA Bidder pursuant to submission of the ASBA Form, or during the Anchor Investor Bid/Offer Period by an Anchor Investor pursuant to submission of the Anchor Investor Application Form, to subscribe to or purchase the Equity Shares of our Company at a price within the Price Band, including all revisions and modifications thereto as permitted under the SEBI ICDR Regulations. The term “Bidding” shall be construed accordingly
Bid Amount	The highest value of optional Bids indicated in the Bid cum Application Form and payable by the Bidder or blocked in the ASBA Account of the Bidder, as the case may be, upon submission of the Bid
Bid cum Application Form	The Anchor Investor Application Form or the ASBA Form, as the context requires
Bid Lot	[●] Equity Shares
Bid/Offer Closing Date	Except in relation to any Bids received from the Anchor Investors, the date after which the Designated Intermediaries will not accept any Bids, being [●], which shall be published in [●] editions of [●] (a widely circulated English national daily newspaper), and [●] editions of [●] (a widely circulated Hindi national daily newspaper, Hindi also being the regional language of New Delhi, where our Registered Office is located). In case of any revisions, the extended Bid/Offer Closing Date shall also be notified on the websites and terminals of the Syndicate Members, as required under the SEBI ICDR Regulations. Our Company and the Investor Selling Shareholders may, in consultation with the BRLMs, consider closing the Bid/Offer Period for the QIB Category one Working Day prior to the Bid/Offer Closing Date in accordance with the SEBI ICDR Regulations
Bid/Offer Opening Date	Except in relation to any Bids received from the Anchor Investors, the date on which the Designated Intermediaries shall start accepting Bids, being [●], which shall be published in [●] editions of [●] (a widely circulated English national daily newspaper), and [●] editions of [●] (a widely circulated Hindi national daily newspaper, Hindi also being the regional language of New Delhi, where our Registered Office is located)
Bid/Offer Period	Except in relation to Anchor Investors, the period between the Bid/Offer Opening Date and the Bid/Offer Closing Date, inclusive of both days, during which prospective Bidders can submit their Bids, including any revisions thereof, in accordance with the SEBI ICDR Regulations

<b>Term</b>	<b>Description</b>
Bidder	Any prospective investor who makes a Bid pursuant to the terms of the Red Herring Prospectus and the Bid cum Application Form and unless otherwise stated or implied, includes an Anchor Investor
Bidding Centers	Centers at which at the Designated Intermediaries shall accept the ASBA Forms, i.e, Designated SCSB Branches for SCSBs, Specified Locations for Syndicate, Broker Centres for Registered Brokers, Designated RTA Locations for RTAs and Designated CDP Locations for CDPs
Book Building Process	Book building process, as provided in Schedule XIII of the SEBI ICDR Regulations, in terms of which the Offer is being made
Book Running Lead Managers or BRLMs	The book running lead managers to the Offer namely, Axis Capital Limited, Motilal Oswal Investment Advisors Limited and SBI Capital Markets Limited
Broker Centres	Broker centres notified by the Stock Exchanges where Bidders can submit the ASBA Forms to a Registered Broker  The details of such Broker Centres, along with the names and contact details of the Registered Broker are available on the respective websites of the Stock Exchanges (www.bseindia.com and www.nseindia.com)
“CAN” or “Confirmation of Allocation Note”	Notice or intimation of allocation of the Equity Shares sent to Anchor Investors, who have been allocated the Equity Shares, after the Anchor Investor Bid/Offer Period
Cap Price	The higher end of the Price Band, above which the Offer Price and the Anchor Investor Offer Price will not be finalised and above which no Bids will be accepted
Cash Escrow Agreement	Agreement to be entered into by our Company, the Selling Shareholders, the Registrar to the Offer, the BRLMs and the Bankers to the Offer for collection of the Bid Amounts from Anchor Investors, transfer of funds to the Public Offer Account and where applicable, refunds of the amounts collected from Bidders, on the terms and conditions thereof
Client ID	Client identification number maintained with one of the Depositories in relation to demat account
“Collecting Depository Participant” or “CDP”	A depository participant as defined under the Depositories Act, 1996, registered with SEBI and who is eligible to procure Bids at the Designated CDP Locations as per the list available on the websites of BSE and NSE
Cut-off Price	Offer Price, finalised by our Company and the Investor Selling Shareholders, in consultation with the BRLMs, which shall be any price within the Price Band  Only Retail Individual Bidders are entitled to Bid at the Cut-off Price. QIBs and Non-Institutional Bidders are not entitled to Bid at the Cut-off Price
Demographic Details	Details of the Bidders including the Bidder’s address, name of the Bidder’s father/husband, investor status, occupation and bank account details
Designated CDP Locations	Such locations of the CDPs where Bidders can submit the ASBA Forms. The details of such Designated CDP Locations, along with names and contact details of the Collecting Depository Participants eligible to accept ASBA Forms are available on the respective websites of the Stock Exchanges (www.bseindia.com and www.nseindia.com)
Designated Date	The date on which funds are transferred from the Escrow Account and the amounts blocked by the SCSBs are transferred from the ASBA Accounts, as the case may be, to the Public Offer Account or the Refund Account, as appropriate, in terms of the Red Herring Prospectus and the Prospectus, following which the Board may Allot Equity Shares to successful Bidders in the Offer
Designated Intermediaries	Syndicate, sub-syndicate/agents, SCSBs, Registered Brokers, CDPs and RTAs, who are authorized to collect ASBA Forms from the ASBA Bidders, in relation to the Offer



<b>Term</b>	<b>Description</b>
Designated RTA Locations	Such locations of the RTAs where Bidders can submit the ASBA Forms to RTAs. The details of such Designated RTA Locations, along with names and contact details of the RTAs eligible to accept ASBA Forms are available on the respective websites of the Stock Exchanges (www.bseindia.com and www.nseindia.com)
Designated SCSB Branches	Such branches of the SCSBs which shall collect the ASBA Forms, a list of which is available on the website of SEBI at www.sebi.gov.in/sebiweb/other/OtherAction.do?doRecognised=yes Intermediaries or at such other website as may be prescribed by SEBI from time to time
Designated Stock Exchange	[●]
“Draft Red Herring Prospectus” or “DRHP”	This draft red herring prospectus dated December 5, 2018 issued in accordance with the SEBI ICDR Regulations, which does not contain complete particulars of the price at which the Equity Shares will be Allotted and the size of the Offer including any addenda or corrigenda thereto
Eligible NRI(s)	NRI(s) from jurisdictions outside India where it is not unlawful to make an offer or invitation under the Offer and in relation to whom the ASBA Form and the Red Herring Prospectus will constitute an invitation to subscribe to or to purchase the Equity Shares
Escrow Account	Account opened with the Escrow Collection Bank(s) and in whose favour the Anchor Investors will transfer money through direct credit/NEFT/RTGS/NACH in respect of the Bid Amount when submitting a Bid
Escrow Collection Bank(s)	Banks which are clearing members and registered with SEBI as bankers to an issue and with whom the Escrow Accounts will be opened, in this case being [●]
First Bidder	Bidder whose name shall be mentioned in the Bid cum Application Form or the Revision Form and in case of joint Bids, whose name shall also appear as the first holder of the beneficiary account held in joint names
Floor Price	The lower end of the Price Band, subject to any revision thereto, at or above which the Offer Price and the Anchor Investor Offer Price will be finalised and below which no Bids will be accepted
Fresh Issue	The fresh issue of [●] Equity Shares aggregating up to ₹ 1,000 million by our Company
Maximum RIB Allottees	Maximum number of RIBs who can be allotted the minimum Bid Lot. This is computed by dividing the total number of Equity Shares available for Allotment to RIBs by the minimum Bid Lot
Motilal Oswal	Motilal Oswal Investment Advisors Limited
Mutual Fund Portion	5% of the QIB Portion (excluding the Anchor Investor Portion), or [●] Equity Shares which shall be available for allocation to Mutual Funds only on a proportionate basis, subject to valid Bids being received at or above the Offer Price
Mutual Funds	Mutual funds registered with SEBI under the Securities and Exchange Board of India (Mutual Funds) Regulations, 1996
Net Proceeds	Proceeds of the Fresh Issue less our Company’s share of the Offer related expenses. For further information about use of the Offer Proceeds and the Offer related expenses, see “ <i>Objects of the Offer</i> ” beginning on page 76
Net QIB Portion	The portion of the QIB Portion less the number of Equity Shares Allotted to the Anchor Investors
“Non-Institutional Bidder” or “NIBs”	All Bidders that are not QIBs or Retail Individual Bidders and who have Bid for Equity Shares for an amount more than ₹ 200,000 (but not including NRIs other than Eligible NRIs)
Non-Institutional Portion	The portion of the Offer being not less than 15% of the Offer consisting of [●] Equity Shares which shall be available for allocation on a proportionate basis to Non-Institutional Bidders, subject to valid Bids being received at or above the Offer Price

Term	Description
Non-Resident	A person resident outside India, as defined under FEMA and includes NRIs, FPIs and FVCIs
Offer	The public issue of [●] Equity Shares of face value of ₹10 each for cash at a price of ₹ [●] each, aggregating up to ₹ [●] million comprising the Fresh Issue and the Offer for Sale
Offer Agreement	The agreement dated December 5, 2018 amongst our Company, the Selling Shareholders and the BRLMs, pursuant to which certain arrangements are agreed to in relation to the Offer
Offer for Sale	The offer for sale of 13,060,770 Equity Shares aggregating up to ₹ [●] million, comprising 2,154,192 Equity Shares by Ambadevi aggregating up to ₹ [●] million and 7,180,642 Equity Shares by Ashoka aggregating up to ₹ [●] million, and 177,378 Equity Shares by Andrew Warren Code aggregating up to ₹ [●] million and 16,366 Equity Shares by Bradley Lorenz Miller aggregating up to ₹ [●] million and 5,010 Equity Shares by Craig A Johnson aggregating up to ₹ [●] million and 57,420 Equity Shares by Dennis Francis DeDecker aggregating up to ₹ [●] million and 8,340 Equity Shares by Diana Lynn Craig aggregating up to ₹ [●] million and 177,378 Equity Shares by James Norman Hallene aggregating up to ₹ [●] million and 177,378 Equity Shares by Kevin John Code aggregating up to ₹ [●] million and 7,710 Equity Shares by Marc Christopher Dorau aggregating up to ₹ [●] million and 20,870 Equity Shares by Mark Louis Dawson aggregating up to ₹ [●] million and 10,440 Equity Shares by Mary Louise Arp aggregating up to ₹ [●] million and 1,444,280 Equity Shares by Meher Soni aggregating up to ₹ [●] million and 41,730 Equity Shares by Melvin Keith Gibbs aggregating up to ₹ [●] million and 826 Equity Shares by Misty Marie Garcia aggregating up to ₹ [●] million and 1,534,548 Equity Shares by Pamela Soni aggregating up to ₹ [●] million and 24,706 Equity Shares by Walter James Gruber aggregating up to ₹ [●] million and 21,556 Equity Shares by Wendy Reichard Hammen aggregating up to ₹ [●] million
Offer Price	The final price at which Equity Shares will be Allotted to successful Bidders, other than Anchor Investors. Equity Shares will be Allotted to Anchor Investors at the Anchor Investor Offer Price in terms of the Red Herring Prospectus. The Offer Price will be decided by our Company and the Investor Selling Shareholders, in consultation with the BRLMs on the Pricing Date, in accordance with the Book-Building Process and in terms of the Red Herring Prospectus
Offer Proceeds	The proceeds of the Fresh Issue which shall be available to our Company and the proceeds of the Offer for Sale which shall be available to the Selling Shareholders. For further information about use of the Offer Proceeds, see “ <i>Objects of the Offer</i> ” beginning on page 76
Price Band	Price band of a minimum price of ₹ [●] per Equity Share (Floor Price) and the maximum price of ₹ [●] per Equity Share (Cap Price) including any revisions thereof. The Price Band and the minimum Bid Lot for the Offer will be decided by our Company and the Investor Selling Shareholders in consultation with the BRLMs, and will be advertised, in [●] editions of the [●] (a widely circulated English national daily newspaper) and [●] editions of [●] (a widely circulated Hindi national daily newspaper, Hindi also being the regional language of New Delhi where our Registered Office is located), at least two Working Days prior to the Bid/Offer Opening Date, with the relevant financial ratios calculated at the Floor Price and at the Cap Price, and shall be made available to the Stock Exchanges for the purpose of uploading on their respective websites
Pricing Date	The date on which our Company and the Investor Selling Shareholders in consultation with the BRLMs, will finalise the Offer Price
Prospectus	The Prospectus to be filed with the RoC after the Pricing Date in accordance with Section 26 of the Companies Act, 2013, and the SEBI ICDR Regulations containing, <i>inter alia</i> , the Offer Price that is determined at the end of the Book Building Process, the size of the Offer and certain other information, including any addenda or corrigenda thereto

<b>Term</b>	<b>Description</b>
Public Offer Account	Bank account to be opened with the Public Offer Account Bank under Section 40(3) of the Companies Act, 2013, to receive monies from the Escrow Account and ASBA Accounts on the Designated Date
Public Offer Account Bank	The bank with which the Public Offer Account is opened for collection of Bid Amounts from Escrow Account and ASBA Account on the Designated Date, in this case being [●]
“QIB Category” or “QIB Portion”	The portion of the Offer (including the Anchor Investor Portion) being not more than 50% of the Offer consisting of [●] Equity Shares which shall be Allotted to QIBs (including Anchor Investors)
“Qualified Institutional Buyers” or “QIBs” or “QIB Bidders”	Qualified institutional buyers as defined under Regulation 2(1)(ss) of the SEBI ICDR Regulations
“Red Herring Prospectus” or “RHP”	The red herring prospectus to be issued in accordance with Section 32 of the Companies Act, 2013 and the provisions of the SEBI ICDR Regulations, which will not have complete particulars of the price at which the Equity Shares will be offered and the size of the Offer including any addenda or corrigenda thereto  The Red Herring Prospectus will be registered with the RoC at least three days before the Bid/Offer Opening Date and will become the Prospectus upon filing with the RoC after the Pricing Date
Refund Account(s)	The account(s) opened with the Refund Bank(s), from which refunds, if any, of the whole or part of the Bid Amount to the Anchor Investors shall be made
Refund Bank(s)	The Banker(s) to the Offer with whom the Refund Account(s) will be opened, in this case being [●]
Registered Brokers	Stock brokers registered with the stock exchanges having nationwide terminals, other than the BRLMs and the Syndicate Members and eligible to procure Bids
Registrar Agreement	The agreement dated December 3, 2018 among our Company, the Selling Shareholders and the Registrar to the Offer in relation to the responsibilities and obligations of the Registrar to the Offer pertaining to the Offer
“Registrar and Share Transfer Agents” or “RTAs”	Registrar and share transfer agents registered with SEBI and eligible to procure Bids at the Designated RTA Locations as per the lists available on the websites of BSE and NSE
“Registrar to the Offer” or “Registrar”	Link Intime India Private Limited
“Retail Individual Bidder(s)” or “RIB(s)”	Individual Bidders who have Bid for the Equity Shares for an amount not more than ₹200,000 in any of the bidding options in the Offer (including HUFs applying through their karta and Eligible NRIs and does not include NRIs other than Eligible NRIs)
Retail Portion	The portion of the Offer being not less than 35% of the Offer consisting of [●] Equity Shares which shall be available for allocation to Retail Individual Bidders in accordance with the SEBI ICDR Regulations, subject to valid Bids being received at or above the Offer Price
Revision Form	Form used by the Bidders to modify the quantity of the Equity Shares or the Bid Amount in any of their ASBA Form(s) or any previous Revision Form(s)  QIB Bidders and Non-Institutional Bidders are not allowed to withdraw or lower their Bids (in terms of quantity of Equity Shares or the Bid Amount) at any stage. Retail Individual Bidders can revise their Bids during the Bid/Offer Period and withdraw their Bids until Bid/Offer Closing Date.
SBICAP	SBI Capital Markets Limited
“Self Certified Syndicate Bank(s)” or “SCSB(s)”	The banks registered with SEBI, offering services in relation to ASBA, a list of which is available on the website of SEBI at <a href="http://www.sebi.gov.in/sebiweb/other/OtherAction.do?doRecognised=yes">www.sebi.gov.in/sebiweb/other/OtherAction.do?doRecognised=yes</a> and updated from time to time and at such other websites as may be prescribed by SEBI from time to time

Term	Description
Share Escrow Agent	Escrow agent appointed pursuant to the Share Escrow Agreement, namely, [●]
Share Escrow Agreement	Agreement to be entered into amongst the Selling Shareholders, our Company and the Share Escrow Agent in connection with the transfer of Equity Shares under the Offer for Sale by such Selling Shareholders and credit of such Equity Shares to the demat account of the Allottees
Specified Locations	Bidding centres where the Syndicate shall accept ASBA Forms from Bidders
Syndicate Agreement	Agreement to be entered into among our Company, the Registrar to the Offer, the Selling Shareholders, the BRLMs and the Syndicate Members in relation to collection of Bid cum Application Forms by Syndicate
Syndicate Members	Intermediaries registered with SEBI who are permitted to carry out activities as an underwriter, namely, [●]
Syndicate	Together, the BRLMs and the Syndicate Members
Systemically Important Non-Banking Financial Company	Systemically important non-banking financial company as defined under Regulation 2(1)(iii) of the SEBI ICDR Regulations
Underwriters	[●]
Underwriting Agreement	The agreement among the Underwriters, our Company and the Selling Shareholders to be entered into on or after the Pricing Date, but prior to the filing of the Prospectus with the RoC
Working Day	All days on which commercial banks in Mumbai are open for business; provided however, with reference to (a) announcement of Price Band; and (b) Bid/Offer Period, “Working Day” shall mean all days, excluding all Saturdays, Sundays and public holidays, on which commercial banks in Mumbai are open for business; (c) the time period between the Bid/Offer Closing Date and the listing of the Equity Shares on the Stock Exchanges, “Working Day” shall mean all trading days of Stock Exchanges, excluding Sundays and bank holidays, as per the circulars issued by SEBI

#### Technical / Industry Related Terms

Term	Description
3PL	3-Point Linkage systems
CAD	Computer-aided design
CFM	Construction, forestry and mining
CNC	Computer numerical control
CNH	CNH Global N.V.
CRISIL Report	Report titled “ <i>Global market assessment of 3PL and PMP products in Agriculture and Construction Equipments</i> ” dated November 29, 2018 prepared by CRISIL Research
Direct Exports	Our export sales from Indian locations directly to overseas customers
EDI	Electronic data interchange
FIFO	First-in-first-out
GKN	GKN Walterscheid GmbH
F&S Report	Report titled “ <i>Global Mobile Hydraulic Equipment Market, Forecast to 2023 – Renewed Investments in Infrastructure, Logistics, and Energy to Support the Recovery in the Mobile Hydraulic Equipment Sector</i> ” dated July 2018 prepared by Frost & Sullivan
HYD Cylinder	Hydraulic cylinder
International Sales	Our sales in regions outside India
John Deere	Deere & Company
Kubota	Kubota Manufacturing of America Corporation
Local Deliveries	Sales from our manufacturing facilities in their respective domestic markets
MIG	Metal inert gas
OEM(s)	Original equipment manufacturer(s)
OHVs	Off-highway vehicles
PCFC	Pre-shipment credit in foreign currency(ies)
PMP	Precision machined parts
PTO	Power take off
SPM	Special purpose machinery

TAFE	Tractors and Farm Equipment Limited
VMC	Vertical machining center
Warehouse Sales	Sales from our warehousing facilities in their respective domestic markets
Yanmar	Yanmar Company Limited

### Conventional and General Terms / Abbreviations

Term	Description
“₹”, “Rs.”, “Rupees” or “INR”	Indian Rupees
AGM	Annual general meeting
AIF	Alternative Investment Fund as defined in and registered with SEBI under the SEBI AIF Regulations
Air Act	Air (Prevention and Control of Pollution) Act, 1981
“AS” or “Accounting Standards”	Accounting Standards issued by the ICAI
“Bn” or “bn”	Billion
BSE	BSE Limited
CAGR	Compound Annual Growth Rate, which is computed by dividing the value of an investment at the year-end by its value at the beginning of that period, raise the result to the power of one divided by the period length, and subtract one from the subsequent result : $((\text{End Value}/\text{Start Value})^{(1/\text{Periods})} - 1)$
Category I FPI(s)	FPIs who are registered as “Category I foreign portfolio investors” under the SEBI FPI Regulations
Category II FPI(s)	FPIs who are registered as “Category II foreign portfolio investors” under the SEBI FPI Regulations
Category III FPI(s)	FPIs who are registered as “Category III foreign portfolio investors” under the SEBI FPI Regulations
CDSL	Central Depository Services (India) Limited
Companies Act	Companies Act, 1956 and the Companies Act, 2013, as applicable
Companies Act, 1956	Companies Act, 1956 (without reference to the provisions thereof that have ceased to have effect upon notification of the sections of the Companies Act, 2013) along with the relevant rules made thereunder
Companies Act, 2013	Companies Act, 2013, to the extent in force pursuant to the notification of the Notified Sections, along with the relevant rules, regulations, clarifications, circulars and notifications issued thereunder
“CRISIL” or “CRISIL Research”	CRISIL Limited
CY	Calendar Year
Depositories	Together, NSDL and CDSL
Depositories Act	Depositories Act, 1996
DIN	Director Identification Number
DP ID	Depository Participant’s Identification
“DP” or “Depository Participant”	A depository participant as defined under the Depositories Act
EBITDA	Earnings before Interest, Taxes, Depreciation and Amortization, which is calculated by adding finance cost and depreciation and amortization expense to Profit before exceptional items
EGM	Extraordinary General Meeting
Environment Protection Act	The Environment Protection Act, 1986
EPS	Earnings per Share
Factories Act	Factories Act, 1948

<b>Term</b>	<b>Description</b>
FDI	Foreign Direct Investment
FEMA	Foreign Exchange Management Act, 1999, read with rules and regulations thereunder
FEMA Regulations	Foreign Exchange Management (Transfer or Issue of Security by a Person Resident Outside India) Regulations, 2017
“Financial Year”, “Fiscal”, “fiscal”, “Fiscal Year” or “FY”	Unless stated otherwise, the period of 12 months ending March 31 of that particular year
FIPB	The erstwhile Foreign Investment Promotion Board
FPI(s)	Foreign Portfolio Investors as defined under the SEBI FPI Regulations
Frost & Sullivan	Frost & Sullivan (India) Private Limited
FVCI	Foreign Venture Capital Investors as defined and registered under the SEBI FVCI Regulations
GDP	Gross domestic product
“GoI” or “Government”	Government of India
GST	Goods and services tax
Hazardous Waste Rules	Hazardous and Other Wastes (Management and Transboundary Movement) Rules, 2016
ICAI	The Institute of Chartered Accountants of India
IMF	International Monetary Fund
“Income Tax Act” or “IT Act”	Income Tax Act, 1961
Ind AS	Indian Accounting Standards as referred to in and notified by the Ind AS Rules
Ind AS Rules	The Companies (Indian Accounting Standard) Rules, 2015
India	Republic of India
Indian GAAP	Generally Accepted Accounting Principles in India
IPO	Initial public offering
IRDAI	Insurance Regulatory and Development Authority of India
ISO	International Organization for Standardization
IST	Indian Standard Time
MCLR	Marginal cost of funds based lending rate
MCA	Ministry of Corporate Affairs, Government of India
“Mn” or “mn”	Million
MT	Metric Tonne
“N.A.” or “NA”	Not Applicable
NACH	National Automated Clearing House
NAV	Net Asset Value
NEFT	National Electronic Fund Transfer
No.	Number
Notified Sections	The sections of the Companies Act, 2013 that were notified by the Ministry of Corporate Affairs, Government of India
NR	Non-resident
NRE Account	Non Resident External Account
NRI	A person resident outside India, who is a citizen of India as defined under the Foreign Exchange Management (Deposit) Regulations, 2016 or an ‘Overseas Citizen of India’

<b>Term</b>	<b>Description</b>
	cardholder within the meaning of Section 7(A) of the Citizenship Act, 1955
NRO Account	Non Resident Ordinary Account
NSDL	National Securities Depository Limited
NSE	National Stock Exchange of India Limited
“OCB” or “Overseas Corporate Body”	A company, partnership, society or other corporate body owned directly or indirectly to the extent of at least 60% by NRIs including overseas trusts, in which not less than 60% of beneficial interest is irrevocably held by NRIs directly or indirectly and which was in existence on October 3, 2003 and immediately before such date had taken benefits under the general permission granted to OCBs under FEMA. OCBs are not allowed to invest in the Offer
p.a.	Per annum
P/E Ratio	Price/Earnings Ratio
PAN	Permanent Account Number
RBI	Reserve Bank of India
Regulation S	Regulation S under the U.S. Securities Act
RTGS	Real Time Gross Settlement
SCRA	Securities Contracts (Regulation) Act, 1956
SCRR	Securities Contracts (Regulation) Rules, 1957
SEBI	Securities and Exchange Board of India constituted under the SEBI Act, 1992
SEBI Act	Securities and Exchange Board of India Act 1992
SEBI AIF Regulations	Securities and Exchange Board of India (Alternative Investments Funds) Regulations, 2012
SEBI FPI Regulations	Securities and Exchange Board of India (Foreign Portfolio Investors) Regulations, 2014
SEBI FVCI Regulations	Securities and Exchange Board of India (Foreign Venture Capital Investors) Regulations, 2000
SEBI Listing Regulations	Securities and Exchange Board of India (Listing Obligations and Disclosure Requirements) Regulations, 2015
SEBI ICDR Regulations	Securities and Exchange Board of India (Issue of Capital and Disclosure Requirements) Regulations, 2018
SEBI SBEB Regulations	Securities and Exchange Board of India (Share Based Employee Benefits) Regulations, 2014
SEBI VCF Regulations	Securities and Exchange Board of India (Venture Capital Fund) Regulations, 1996, as repealed by the SEBI AIF Regulations
Stock Exchanges	Together, BSE and NSE
STT	Securities Transaction Tax
Takeover Regulations	Securities and Exchange Board of India (Substantial Acquisition of Shares and Takeovers) Regulations, 2011
Trademarks Act	Trade Marks Act, 1999
UPI	Unified Payments Interface
“U.S.” or “USA” or “United States”	United States of America
U.S. GAAP	Generally Accepted Accounting Principles in the United States of America
“USD” or “US\$”	United States Dollars
U.S. Securities Act	U.S. Securities Act of 1933

Term	Description
VAT	Value Added Tax
VCFs	Venture Capital Funds as defined in and registered with SEBI under the SEBI VCF Regulations
Wilful Defaulter(s)	Wilful defaulter as defined under Regulation 2(1)(III) of the SEBI ICDR Regulations



## PRESENTATION OF FINANCIAL, INDUSTRY AND MARKET DATA

### Certain Conventions

All references to “India” contained in this Draft Red Herring Prospectus are to the Republic of India.

Unless stated otherwise, all references to page numbers in this Draft Red Herring Prospectus are to the page numbers of this Draft Red Herring Prospectus.

### Financial Data

Unless stated otherwise, the financial information in this Draft Red Herring Prospectus is derived from our Restated Financial Statements. Certain additional financial information pertaining to our Group Company is derived from its financial statements. The Restated Financial Statements included in this Draft Red Herring Prospectus are as at and for the six month period ended September 30, 2018 and the Fiscals ended March 31, 2018, March 31, 2017 and March 31, 2016, and have been prepared in accordance with Ind AS as prescribed under Section 133 of Companies Act, 2013 read with Companies (Indian Accounting Standards) Rules, 2015 and other relevant provisions of the Companies Act, 2013 and the guidance notes issued by ICAI. For further information, see “*Financial Information*” beginning on page 162.

In this Draft Red Herring Prospectus, any discrepancies in any table between the total and the sums of the amounts listed are due to rounding off. All figures in decimals have been rounded off to the second decimal and all percentage figures have been rounded off to two decimal places.

Our Company’s financial year commences on April 1 and ends on March 31 of the next year. Accordingly, all references to a particular financial year, unless stated otherwise, are to the 12 month period ended on March 31 of that year. Unless stated otherwise, or the context requires otherwise, all references to a “year” in this Draft Red Herring Prospectus are to a calendar year.

Unless the context otherwise indicates, any percentage amounts, as set forth in “*Risk Factors*”, “*Our Business*” and “*Management’s Discussion and Analysis of Financial Condition and Results of Operations*” beginning on pages 21, 113 and 241, respectively, and elsewhere in this Draft Red Herring Prospectus have been calculated on the basis of our Restated Financial Statements.

Consequent to the introduction of Goods and Service Tax (“GST”) central excise and value added tax have been subsumed into GST. In accordance with Ind AS 18, GST is not considered a part of revenue unlike excise duties which used to be included in revenue prior to July 1, 2017. Accordingly, our results of operations and our EBITDA for Fiscal 2018 are not directly comparable with the previous Fiscals.

### Currency and Units of Presentation

All references to:

- “Rupees” or “₹” or “INR” or “Rs.” are to Indian Rupee, the official currency of the Republic of India;
- “USD” or “US\$” are to United States Dollar, the official currency of the United States; and
- “EUR” or “€” are to Euro, the official currency of the European Union.

Our Company has presented certain numerical information in this Draft Red Herring Prospectus in “million” units. One million represents 1,000,000 and one billion represents 1,000,000,000.

### Exchange Rates

This Draft Red Herring Prospectus contains conversion of certain other currency amounts into Indian Rupees. These conversions should not be construed as a representation that these currency amounts could have been, or can be converted into Indian Rupees, at any particular rate or at all.

The following table sets forth, for the periods indicated, information with respect to the exchange rate between Rupee and US\$ (in Rupees per US\$); and Rupee and € (in Rupees per €):

(Amount in ₹, unless otherwise specified)

Currency	As at			
	September 30, 2018*	March 31, 2018**	March 31, 2017	March 31, 2016
1 US\$	72.55	64.04	64.84	66.33
1 €	84.10	69.25	69.25	75.10

Source: RBI Reference Rate

\* Exchange rate as on September 28, 2018, as RBI reference rate is not available for September 30, 2018 and September 29, 2018 being a Saturday and Sunday, respectively.

\*\* Exchange rate as on March 28, 2018, as RBI reference rate is not available for March 31, 2018, March 30, 2018 and March 29, 2018 being a Saturday and public holidays, respectively.

## Industry and Market Data

Unless stated otherwise, industry and market data used in this Draft Red Herring Prospectus has been obtained or derived from the report titled “Global market assessment of 3PL and PMP products in Agriculture and Construction Equipments” dated November 29, 2018 prepared by CRISIL Research (“**CRISIL Report**”) and the report titled “Global Mobile Hydraulic Equipment Market, Forecast to 2023 – Renewed Investments in Infrastructure, Logistics, and Energy to Support the Recovery in the Mobile Hydraulic Equipment Sector” dated July 2018 prepared by Frost & Sullivan (“**F&S Report**”).

The CRISIL Report has been prepared at the request of our Company. In relation to the CRISIL Report, please see below the disclaimer specified in their consent letter dated November 30, 2018 issued to our Company:

*“CRISIL Research, a division of CRISIL Limited (CRISIL) has taken due care and caution in preparing this report (Report) based on the Information obtained by CRISIL from sources which it considers reliable (Data). However, CRISIL does not guarantee the accuracy, adequacy or completeness of any material contained in or referred to in the Report. While CRISIL takes reasonable care in preparing the Report, CRISIL shall not be responsible for any errors or omissions in or for the results obtained from the use of or decision made based on the Report. This Report is not a recommendation to invest / disinvest in any entity covered in the Report and no part of this Report should be construed as an expert advice or investment advice or any form of investment banking within the meaning of any law or regulation. CRISIL undertakes no responsibility to update the contents of the Report for any changes which may take place post the date of issuance of this Report. CRISIL especially states that it has no liability whatsoever to the subscribers / users / transmitters / distributors of this Report. Without limiting the generality of the foregoing, nothing in the Report is to be construed as CRISIL providing or intending to provide any services in jurisdictions where CRISIL does not have the necessary permission and/or registration to carry out its business activities in this regard. Uniparts India Limited will be responsible for ensuring compliances and consequences of non - compliances for use of the Report or part thereof outside India. CRISIL Research operates independently of, and does not have access to information obtained by CRISIL’s Ratings Division / CRISIL Risk and Infrastructure Solutions Ltd (CRIS), which may, in their regular operations, obtain information of a confidential nature. The views expressed in this Report are that of CRISIL Research and not of CRISIL’s Ratings Division / CRIS. No part of this Report may be published/reproduced in any form without CRISIL’s prior written approval.”*

Industry publications generally state that the information contained in such publications has been obtained from publicly available documents from various sources believed to be reliable but their accuracy and completeness are not guaranteed and their reliability cannot be assured. Accordingly, no investment decisions should be based on such information. Although we believe the industry and market data used in this Draft Red Herring Prospectus is reliable, it has not been independently verified by us, the Selling Shareholders or the BRLMs or any of their affiliates or advisors. The data used in these sources may have been re-classified by us for the purposes of presentation. Data from these sources may also not be comparable. Such data involves risk, uncertainties and assumptions, and is subject to change based on various factors. Accordingly, investment decisions should not be based solely on such information. For details in relation to the risks involving the CRISIL Report and F&S Report, see “Risk Factors” beginning on page 21.

The extent to which the market and industry data used in this Draft Red Herring Prospectus is meaningful depends on the reader’s familiarity with and understanding of the methodologies used in compiling such data. There are no standard data gathering methodologies in the industry in which business of our Company is conducted, and methodologies and assumptions may vary widely among different industry sources.

## FORWARD-LOOKING STATEMENTS

This Draft Red Herring Prospectus contains certain “forward-looking statements”. These forward-looking statements generally can be identified by words or phrases such as “aim”, “anticipate”, “believe”, “expect”, “estimate”, “intend”, “objective”, “plan”, “propose”, “project”, “will”, “will continue”, “will pursue” or other words or phrases of similar import. Similarly, statements that describe our strategies, objectives, plans or goals are also forward-looking statements. All forward-looking statements are subject to risks, uncertainties and assumptions about us that could cause actual results to differ materially from those contemplated by the relevant forward-looking statement.

Actual results may differ materially from those suggested by forward-looking statements due to risks or uncertainties associated with expectations relating to, *inter alia*, regulatory changes pertaining to the industries in India in which we operate and our ability to respond to them, our ability to successfully implement our strategy, our growth and expansion, technological changes, our exposure to market risks, general economic and political conditions in India which have an impact on its business activities or investments, the monetary and fiscal policies of India, inflation, deflation, unanticipated turbulence in interest rates, foreign exchange rates, equity prices or other rates or prices, the performance of the financial markets in India and globally, changes in domestic laws, regulations and taxes and changes in competition in the industries in which we operate.

Certain important factors that could cause actual results to differ materially from our expectations include, but are not limited to, the following:

- Dependence on limited number of customers for a significant portion of our revenues.
- Inability to accurately forecast demand for our products.
- Exposure to foreign currency exchange rate fluctuations.
- Inability to retain and hire Key Managerial Personnel or to maintain good relations with our workforce.
- Work stoppages, strikes or other types of conflicts with our employees or contract workers.
- Availability and cost of raw materials and labour.
- Cyclical effects in the global and domestic economy, specifically in the agriculture and CFM sectors.
- Insufficient cash flows to enable us to fund working capital requirements or to service our short term (current) borrowing.

For further discussion on factors that could cause actual results to differ from expectations, see “*Risk Factors*”, “*Our Business*” and “*Management’s Discussion and Analysis of Financial Condition and Results of Operations*” beginning on pages 21, 113 and 241, respectively. By their nature, certain market risk disclosures are only estimates and could be materially different from what actually occurs in the future. As a result, actual gains or losses could materially differ from those that have been estimated.

There can be no assurance to investors that the expectations reflected in these forward-looking statements will prove to be correct. Given these uncertainties, investors are cautioned not to place undue reliance on such forward-looking statements and not to regard such statements to be a guarantee of our future performance.

Forward-looking statements reflect current views as of the date of this Draft Red Herring Prospectus and are not a guarantee of future performance. These statements are based on our management’s beliefs and assumptions, which in turn are based on currently available information. Although we believe the assumptions upon which these forward-looking statements are based are reasonable, any of these assumptions could prove to be inaccurate, and the forward-looking statements based on these assumptions could be incorrect. Neither our Company, our Directors, the Selling Shareholders, the BRLMs nor any of their respective affiliates have any obligation to update or otherwise revise any statements reflecting circumstances arising after the date hereof or to reflect the occurrence of underlying events, even if the underlying assumptions do not come to fruition. In accordance with the SEBI ICDR Regulations, our Company and the BRLMs will ensure that the investors in India are informed of material developments until the time of the grant of listing and trading permission by the Stock Exchanges. Each of the Selling Shareholders shall ensure that it will keep the Company and BRLMs informed of all material developments pertaining to its respective portion of the Equity Shares under the Offer for Sale and itself, as Selling Shareholder from the date of the Red Herring Prospectus until receipt of final listing and trading approvals by the Stock Exchanges for this Offer, that may be material from the context of the Offer.

## SUMMARY OF THE OFFER DOCUMENT

### Summary of Business

We are a global manufacturer and supplier of engineering systems, solutions, assemblies and components, including 3-point linkage (“3PL”) systems and precision machined parts, primarily catering to off-highway vehicles in the agriculture, and construction, forestry and mining (“CFM”) sectors. We also have a presence in the complementary product verticals of hydraulic cylinders and power take off applications. We have a global footprint, primarily serve OEMs (across 25 countries during Fiscal 2018), through our global service delivery model based on our dual-shore integrated manufacturing, warehousing and supply chain management systems and solutions. We also cater to the aftermarket requirements of our customers.

### Summary of Industry

Across product lines, the Company primarily caters to off-highway vehicles in the agriculture and CFM sectors. A major driver of 3PL demand is tractors, which is, in turn, a function of agriculture growth. The world market for 3PL is estimated at US\$ 390-410 million in 2017, which grew at a CAGR of around 1% during 2013-2017. Key driver for the construction equipment industry is investment in infrastructure projects. The world market for PMP for articulated joints is estimated to be US\$ 409 million in 2017. Within the hydraulics industry, hydraulic cylinders generated the highest revenue in 2017 (30.6% revenue share).

### Promoters

Our Promoters are Gurdeep Soni and Paramjit Singh Soni.

### Offer Size

Offer	[●] Equity Shares, aggregating up to ₹ [●] million
<i>of which</i>	
Fresh Issue <sup>(1)</sup>	[●] Equity Shares, aggregating up to ₹ 1,000 million
Offer for Sale <sup>(2)</sup>	13,060,770 Equity Shares, aggregating up to ₹ [●] million

(1) The Offer has been authorized by a resolution of our Board dated November 23, 2018 and the Fresh Issue has been authorized by a special resolution of our Shareholders, dated November 27, 2018.

(2) The Equity Shares being offered by the Selling Shareholders have been held for a period of at least one year immediately preceding the date of this Draft Red Herring Prospectus with the SEBI, and are eligible for being offered for sale pursuant to the Offer in terms of the SEBI ICDR Regulations. For details of authorizations received for the Offer for Sale, see “Other Regulatory and Statutory Disclosures” beginning on page 261.

### Objects of the Offer

The Net Proceeds are proposed to be used in accordance with the details provided in the following table:

Particulars	Amount (In ₹ million)
Prepayment/ repayment of all or a portion of the outstanding loan facilities availed by our Company	750.00
General corporate purposes*	[●]

\* The amount utilised for general corporate purposes shall not exceed 25% of the Gross Proceeds of the Fresh Issue.

### Pre-Offer Shareholding of Promoters, Promoter Group and Selling Shareholders

S. No.	Category of Shareholders	No. of Equity Shares	% of total paid up Equity Share capital
1.	Promoters (A)	21,550,660	47.75
2.	Promoter Group (B)	12,439,520	27.56
3.	Investor Selling Shareholders (C <sub>1</sub> )	9,334,834	20.68
	Individual Selling Shareholders* (C <sub>2</sub> )	7,926,628	17.56
4.	Selling Shareholders* (C = C <sub>1</sub> + C <sub>2</sub> )	17,261,462	38.24

\* The Individual Selling Shareholders include Meher Soni and Pamela Soni who form part of our Promoter Group.

### Summary of Financial Information

(in ₹ million other than share data)

Particulars	Six months ended September 30, 2018	Fiscal		
		2018	2017	2016
Share capital	446.20	446.20	446.20	446.20
Net worth	3,884.51	3,645.10	3,178.53	2,941.98
Revenue (total income)	5,157.11	8,461.86	7,031.47	7,795.20
Profit after tax	441.74	535.33	265.20	447.12
Earnings per share (basic and diluted)				
- Basic	10.02	12.14	6.01	10.14

Particulars	Six months ended September 30, 2018	Fiscal		
		2018	2017	2016
- Diluted	9.79	11.86	5.88	9.91
Net asset value per equity share	86.07	80.76	70.42	65.18
Total borrowings	3,131.22	2,471.25	1,947.86	2,303.93

### Qualifications of the Auditors

The Restated Financial Statements do not contain any qualification requiring adjustments by the Auditors.

### Summary of Outstanding Litigation

A summary of outstanding litigation proceedings involving our Company, our Promoters, our Directors, our Subsidiaries and our Group Company as on the date of this Draft Red Herring Prospectus is provided below:

Type of Proceedings*	Number of cases	Amount** (₹ in million)
<b>Cases against our Company</b>		
Actions taken by statutory or regulatory authorities	1	0.23
Direct and indirect taxes	35	78.10
<b>Total</b>	<b>36</b>	<b>78.33</b>
<b>Cases by our Company</b>		
Criminal proceedings	1	19.22
Other pending material litigation	1	67.89
<b>Total</b>	<b>2</b>	<b>87.11</b>
<b>Cases against our Directors***</b>		
Direct and indirect taxes	6	1.76
<b>Total</b>	<b>6</b>	<b>1.76</b>
<b>Cases against our Promoters</b>		
Direct and indirect taxes	6	1.76
<b>Total</b>	<b>6</b>	<b>1.76</b>
<b>Cases against our Subsidiaries</b>		
Direct and indirect taxes	5	1.62
<b>Total</b>	<b>5</b>	<b>1.62</b>

\* There is no pending litigation involving our Group Company which will have a material adverse impact on our Company.

\*\* To the extent quantifiable.

\*\*\* Cases against our Directors include the cases against our Promoters.

For further details of the outstanding litigation proceedings, see “Outstanding Litigation and Material Developments” beginning on page 254.

### Risk Factors

Please see “Risk Factors” beginning on page 21.

### Summary of Contingent Liabilities of our Company

As of September 30, 2018, our capital and other commitments (contingent liabilities) not provided for in our Restated Financial Statements are as follows:

Particulars	(in ₹ million)
As of September 30, 2018	
<b>Claims against the company not acknowledged as debt:</b>	
Sales tax matters	2.34
Service tax matters	0.23
Custom matters	1.60
Excise matters	0.94
Labour matters	Not Ascertainable
<b>Sales tax liability against pending forms</b>	<b>0.74</b>
<b>Income tax demands</b>	<b>0.36</b>
<b>Others</b>	
Guarantees given on behalf of the Company by the banks:	
Sales tax matters	0.03
Pollution Control Board	0.02
Excise matters	0.50
Custom matters	0.00
Gas connections	2.68
<b>SBLC (Stand By Letter of Credit) for wholly owned Subsidiaries</b>	<b>9.25</b>

Particulars	As of September 30, 2018
<b>Bond cum Legal Undertaking to Andhra Pradesh Special Economic Zone and Noida Special Economic Zone</b>	<b>1,699.73</b>

\* In addition estimated amount of contracts remaining to be executed on capital accounts and not provided for (net of advances) is ₹ 120.24 million. For details of our capital and other commitments see "Financial Statements - Annexure VI: Notes to Restated Consolidated Financial Information – 37. Capital and other commitments" on page 217.

For details, see "Financial Statements" on page 162.

### Summary of Related Party Transactions

Particulars	Six months ended September 30, 2018	Fiscal		
		2018	2017	2016
Purchase of tangible asset	-	-	-	67.02
Rent paid	0.94	1.83	1.58	5.27
Current account payments	-	-	-	0.08
Dividend paid	34.00	-	-	25.50
Sitting fees	0.58	0.80	1.10	0.99
Salary and allowances	1.14	2.36	2.36	2.32
Commission	-	1.10	-	-
KMP remuneration	60.13	113.60	109.39	106.08
ESOP granted to KMP	-	-	-	2.78

For details of the related party transactions and as reported in the Restated Financial Statements, see "Financial Information" beginning on page 162.

### Financing Arrangements

There have been no financing arrangements whereby our Promoters, members of the Promoter Group, our Directors and their relatives have financed the purchase by any other person of securities of our Company during a period of six months immediately preceding the date of this Draft Red Herring Prospectus.

### Weighted average price at which the Equity Shares were acquired by each of our Promoters and the Selling Shareholders in the one year preceding the date of this Draft Red Herring Prospectus

None of our Promoters or the Selling Shareholders acquired any Equity Shares in the one year preceding the date of this Draft Red Herring Prospectus.

### Average Cost of Acquisition

The average cost of acquisition per Equity Share to our Promoters and Selling Shareholders as at the date of this Draft Red Herring Prospectus is:

Name	Number of Equity Shares held as on September 30, 2018	Average cost of Acquisition per Equity Share (in Rs.)*
<b>Promoters</b>		
Gurdeep Soni	14,955,570	9.97
Paramjit Singh Soni	6,595,090	17.69
<b>Investor Selling Shareholders**</b>		
Ambadevi	2,154,192	88.45
Ashoka	7,180,642	88.45
<b>Individual Selling Shareholders</b>		
Andrew Warren Code	177,378	105.74
Bradley Lorenz Miller	16,366	105.73
Craig A Johnson	5,010	105.74
Dennis Francis DeDecker	57,420	105.74
Diana Lynn Craig	8,340	105.74
James Norman Hallene	177,378	105.74
Kevin John Code	177,378	105.74
Marc Christopher Dorau	7,710	105.74
Mark Louis Dawson	20,870	147.36
Mary Louise Arp	10,440	105.74
Meher Soni***	5,200,000	5.10
Melvin Keith Gibbs	41,730	105.74
Misty Marie Garcia	826	105.61
Pamela Soni****	1,979,520	9.50
Walter James Gruber	24,706	105.73

Name	Number of Equity Shares held as on September 30, 2018	Average cost of Acquisition per Equity Share (in Rs.)*
Wendy Reichard Hammen	21,556	105.73

\* As certified by Rakesh Banwari & Co., Chartered Accountants, by way of their certificate dated November 28, 2018.

\*\* PineBridge Investments Asia Limited manages and/or are advisors on the investments of Ashoka and Ambadevi. PineBridge Investments does not have any direct shareholding in our Company.

\*\*\* Meher Soni, daughter of our Promoter, Paramjit Singh Soni, forms part of the Promoter Group of our Company. Further, she is not involved in the affairs of our Company.

\*\*\*\* Pamela Soni, wife of our Promoter, Gurdeep Soni, forms part of the Promoter Group of our Company. Further, she is not involved in the affairs of our Company.

#### **Details of pre-Offer Placement**

Our Company does not contemplate any issuance or placement of Equity Shares from the date of this Draft Red Herring Prospectus till the listing of the Equity Shares.

#### **Issue of Equity Shares for consideration other than cash in the last one year**

Our Company has not issued any Equity Shares for consideration other than cash in the one year preceding the date of this Draft Red Herring Prospectus.

#### **Split / Consolidation of Equity Shares in the last one year**

Our Company has not undertaken a split or consolidation of the Equity Shares in the one year preceding the date of this Draft Red Herring Prospectus.

## SECTION II: RISK FACTORS

Any investment in equity shares involves a high degree of risk. You should carefully consider all the information in this Draft Red Herring Prospectus, including the risks, uncertainties and challenges described below, before making an investment in our Equity Shares. The risks described below are not the only ones relevant to us or our Equity Shares or the industry in which we operate. Additional risks and uncertainties not presently known to us or that we deem immaterial may also impair our business, results of operations, financial condition or cash flows. You should read this section in conjunction with “Our Business”, “Industry Overview” and “Management’s Discussion and Analysis of Financial Condition and Results of Operations” on pages 113, 87 and 241, respectively, as well as the other financial and statistical information contained in this Draft Red Herring Prospectus.

If any or a combination of the following risks, or other risks and uncertainties that are not currently known or are now deemed immaterial, actually materialize, our business, financial condition, results of operations and prospects may suffer, the trading price of our Equity Shares may decline, and all or part of your investment in our Equity Shares may be lost. Unless otherwise stated, we are not in a position to specify or quantify the financial or other risks mentioned here.

Unless otherwise stated, the financial information in this section is derived from our Restated Financial Statements.

Unless stated otherwise, industry and market data used in this section has been obtained or derived from publicly available information as well as industry publications, other sources, the report titled “Global market assessment of 3PL and PMP products in Agriculture and Construction Equipments” dated November 29, 2018, prepared by CRISIL Research, a division of CRISIL Limited (“CRISIL” or “CRISIL Research” and such report, the “CRISIL Report”) on our request and the report titled “Global Mobile Hydraulic Equipment Market, Forecast to 2023 – Renewed Investments in Infrastructure, Logistics, and Energy to Support the Recovery in the Mobile Hydraulic Equipment Sector” dated July 2018 prepared by Frost & Sullivan (the “F&S Report”). Unless otherwise indicated, all financial, operational, industry and other related information derived from the CRISIL Report or the F&S Report and included herein with respect to any particular year refers to such information for the relevant calendar year. We commissioned the CRISIL Report for the purposes of confirming our understanding of the industry in connection with the Offer. Neither our Company, nor any other person connected with the Offer, including the BRLMs, has independently verified the information in the CRISIL Report or other publicly available information cited in this section. In this regard also see, “Risk Factors – This Draft Red Herring Prospectus contains information from industry sources including a report commissioned from CRISIL Limited. Prospective investors are advised not to place undue reliance on such information.” on page 43.

This Draft Red Herring Prospectus contains forward-looking statements that involve risks and uncertainties. Our actual results may differ materially from those anticipated in these forward-looking statements as a result of certain factors, including the considerations described below and elsewhere in this Draft Red Herring Prospectus. See “Forward-Looking Statements” on page 16. In making an informed decision, prospective investors must rely on their own examination of the Company and the terms of the Offer, including the merits and risks involved.

### Internal Risk Factors

#### Risks Relating to Our Business

1. ***We depend on a limited number of customers for a significant portion of our revenues. The loss of a major customer or significant reduction in production and sales of, or demand for our products from, any of our major customers may adversely affect our business, financial condition, results of operations and prospects.***

A majority of our revenue from operations is from sales to Original Equipment Manufacturers (“OEMs”). These constituted 82.46%, 85.03%, 84.48% and 84.00% of our revenue from operations for the six months ended September 30, 2018 and in Fiscals 2018, 2017 and 2016, respectively, within which we depend on a limited number of customers for a significant portion of our revenues. Revenue from our top 10 customers across product segments and geographies constituted 77.01%, 77.01%, 77.72% and 79.34% of our revenue from operations for the six months ended September 30, 2018 and Fiscals 2018, 2017 and 2016, respectively. Set forth below are details of our product specific aggregate revenue from our top 10 customers in each product segment for the six months ended September 30, 2018 and the last three Fiscals.

*(in ₹ million, except percentage)*

	Six months ended September 30, 2018	Fiscal 2018	Fiscal 2017	Fiscal 2016
Revenue from top ten customers (3PL)	2,001.17	3,374.77	2,856.63	3,238.50
Revenue from top ten 3PL customers as a percentage of 3PL total sales	81.69%	81.96%	83.57%	84.31%
Revenue from top ten customers (PMP)	2,204.57	3,513.73	3,003.26	3,265.61
Revenue from top ten PMP customers as a percentage of total PMP sales	91.37%	92.47%	96.64%	95.03%



	Six months ended September 30, 2018	Fiscal 2018	Fiscal 2017	Fiscal 2016
Revenue from top ten <sup>1</sup> customers (PTO)	42.99	98.74	83.19	87.90
Revenue from top ten <sup>1</sup> PTO customers as a percentage of total PTO sales	100.00%	100.00%	100.00%	100.00%
Revenue from top ten <sup>2</sup> customers (HYD Cylinders)	13.35	25.60	19.11	15.59
Revenue from top ten <sup>2</sup> HYD Cylinder customers as a percentage of total HYD Cylinder sales	100.00%	100.00%	100.00%	100.00%

<sup>1</sup> We have a single customer in our PTO segment.

<sup>2</sup> We have three customers in our HYD Cylinder segment.

For details of our key customers, see “*Our Business*” on page 113.

Demand for our products is directly related to the production and sales of off-highway vehicles (“OHVs”) by our major customers. OHV production and sales may be affected by general economic or industry conditions, including seasonal trends in the agricultural sector and cyclical effects in the construction, forestry and mining (“CFM”) sector, recessionary trends in the global and domestic economies, volatility in new housing construction as well as evolving regulatory requirements, government initiatives, trade agreements and other factors. For risks relating to cyclical effects which affect our business see “– *Our business is impacted by cyclical effects in the global and domestic economy, specifically in the agriculture and CFM sectors, which may have an adverse effect on our business, financial condition, results of operations and prospects*” on page 27.

It is difficult to forecast events which affect the profitability and liquidity of our customers or the success or sustainability of any strategies undertaken by any of our major customers in response to the current economic or industry environment. Unfavourable industry conditions can also result in an increase in commercial disputes and other risks of supply disruption. A sustained decline in the demand for products produced by our OEM customers could prompt them to cut their production volumes, directly affecting the demand from OEMs for our products.

As our business is currently concentrated among relatively few significant customers, we may experience reduction in cash flows and liquidity if we lose one or more of our major customers or if the amount of business from one or more of them is significantly reduced for any reason, including as a result of a dispute with or disqualification by a major customer.

2. ***If we are unable to accurately forecast demand for our products, our business, cash flows, financial condition, results of operations and prospects may be adversely affected.***

The volume and timing of sales to our customers may vary due to variation in demand for our customers’ products, our customers’ attempts to manage their inventory, design changes, changes in their product mix, manufacturing strategy and growth strategy, and macroeconomic factors affecting the economy in general and our customers in particular. Our inability to accurately forecast the level of customer demand for our products, process innovation and value engineering costs as well as inability to accurately schedule our raw material purchases and production and manage our inventory may adversely affect our business and cash flows from operations. In particular, our inability to accurately forecast demand for products in our emerging product verticals, comprising complementary product verticals of hydraulic cylinders and power take off (“PTO”) applications, may hinder our planned growth in these verticals.

Although we have entered into long-term customer agreements with certain of our key OEM customers in accordance with which such customers provide us with forecasts of business volumes which enable us to predict our income for a portion of our business, the actual orders are only placed by way of on-going purchase orders. OEMs develop new models and refine existing models on an on-going basis and may also phase out some of their existing models. Any or all of these developments by the OEMs may result in changes in product specifications, timing of procurement, etc. of the products/components that they source from our Company and our Subsidiaries. The time taken by these OEMs for new product development and enhancements/refinements is difficult to estimate or predict as these are normally elongated which include conceptualization phase to development phase and then field testing and trials. This is particularly true for OHVs where the long lead times for new OHV models, and related programs for the development and manufacture of our products may make it difficult to predict the timing of income that we will earn in respect of new programs. In addition, actual production volumes may vary from these estimates due to variations in consumer demand for the related products leading to underutilized capacity or incurring additional expenditure to deploy additional resources to meet delivery timelines.

Additionally, in the event of significant cuts in production schedules announced by customers with little advance notice, we may be unable to respond with corresponding production and inventory reductions and we may be required to reorganize our production schedules. Such instances may occur from time to time in the ordinary course of business, including due to changes in product specifications, extremity of weather condition, seasonal/cyclical nature of the sectors in which we operate and global economic downturns affecting the OHV sector, amongst other

things. In particular, we faced such cuts in production, which had materially affected our business during the global financial crisis in 2008 and again during the agriculture and CFM sector slow-down particularly between 2014 and 2016 and there can be no assurance that such instances will not occur in the future. While we have not historically tracked details of revenue losses occurring on this account, a significant reduction in demand for our products from a major customer may have an adverse effect on our business, financial condition, results of operations and prospects.

Further, our global service delivery model could also lead to increased inventory at our warehouses. Sales from our warehousing facilities (“**Warehouse Sales**”) contributed to 38.45%, 34.66%, 31.66% and 31.30% of our revenue from operations for the six months ended September 30, 2018 and Fiscals 2018, 2017 and 2016, respectively, and we expect that the proportion of our Warehouse Sales may increase as compared to export sales from Indian locations directly to overseas customers (“**Direct Exports**”) and sales from our manufacturing facilities in their respective domestic markets (“**Local Deliveries**”), going forward. As a result, this may lead to a mismatch between increased inventory maintained at our warehouses and actual delivery schedules. Set forth below is a detailed break-up of our revenue from operations from such Warehouse Sales, Direct Exports and Local Deliveries for the six months ended September 30, 2018 and for the last three Fiscals.

*(in ₹ million)*

Particulars	Six months ended September 30, 2018	For the year ended March 31		
		2018	2017	2016
<b>Warehouse Sales</b> – sales from our warehousing facilities in their respective markets	1,982.78	2,933.13	2,226.15	2,440.15
<b>Direct Exports</b> – export sales from Indian locations directly to overseas customers	1,152.72	2,106.88	1,862.39	2,124.59
<b>Local Deliveries</b> – sales from our manufacturing facilities in their respective domestic markets	1,809.18	3,091.96	2,691.16	2,970.50

Moreover, as many of our operating expenses are relatively fixed, an unanticipated change in customer demand or preferences may adversely affect our liquidity and financial condition. We typically commit to order raw materials and bought-out components from our own suppliers based on customer forecasts and orders. Cancellation by customers or delay or reduction in their orders or instances where anticipated orders fail to materialize can result in mismatch between our inventories of raw materials and bought-out components and of manufactured products, thereby increasing our costs relating to maintaining our inventory and reduction of our margins, which may adversely affect our profitability and liquidity. From time to time, in the ordinary course of business, our customers may announce reorganization in product scheduling, including due to such unanticipated changes in customer preferences, cancellation by customers or delay or instances where anticipated orders fail to materialize, owing to which our products may become obsolete or unutilized, which adversely affect our business, financial condition, results of operations and prospects. While we have not historically tracked such instances or any resultant loss and believe that such instances in the past have not been significant, there can be no assurance that such instances in the future will not have a material adverse effect on our liquidity, profitability and financial condition. Further, since finished inventory is maintained at our manufacturing facilities and warehouses in anticipation of demand, such products may be susceptible to unanticipated changes in customer preferences which may render our finished products obsolete or unutilized in meeting demand to the extent anticipated, thereby adversely affecting our liquidity and financial position.

3. ***We are exposed to foreign currency exchange rate fluctuations, which may harm our results of operations and cause our results to fluctuate.***

We are exposed to foreign exchange rate fluctuations in respect of (i) our foreign currency denominated borrowings (mainly in US\$), (ii) currency mismatches between our revenues and expenses, and (iii) currency translation losses for the purpose of preparing our consolidated financial statements (which are presented in Indian Rupees), on account of our global operations.

Our revenues, operating expenses and finance costs are influenced by the currencies of those countries where we manufacture and/or sell our products (for example, the United States, Europe and Japan). The exchange rate between the Indian Rupee and these currencies, primarily the US\$, has fluctuated in the past and our results of operations have been impacted by such fluctuations in the past and may be impacted by such fluctuations in the future. For example, during times of strengthening of the Indian Rupee, we expect that our overseas sales and revenues will generally be negatively impacted as foreign currency received will be translated into fewer Indian Rupees. However, the converse positive effect of depreciation in the Indian Rupee may not be sustained or may not show an appreciable impact in our results of operations in any given financial period due to other variables impacting our business and results of operations during the same period. Moreover, as a majority of our long-term (non-current) and working capital borrowings are US\$ denominated, we expect that our cost of borrowing as well as our cost of raw materials and components incurred by our foreign Subsidiaries may rise during a sustained depreciation of the Indian Rupee against the US\$. Set forth below is a detailed break-up of our foreign currency inflows and outflows for the six months ended September 30, 2018 and the last three Fiscals.

	Six months ended September 30, 2018		Fiscal 2018		Fiscal 2017		Fiscal 2016	
	Amount (₹ in million)	% to Revenue from operations	Amount (₹ in million)	% to Revenue from operations	Amount (₹ in million)	% to Revenue from operations	Amount (₹ in million)	% to Revenue from operations
<b>Revenue from Operations</b>	3,191.05	100.00%	5,335.89	100.00%	4,222.38	100.00%	4,606.50	100.00%
Within India	1,246.74	39.07%	2,111.97	39.58%	1,719.92	40.73%	1,644.28	35.69%
Outside India	1,944.31	60.93%	3,223.92	60.42%	2,502.46	59.27%	2,961.22	64.31%
<b>Operating Expenses incurred in Foreign Exchange</b>	92.81	2.91%	101.10	1.89%	110.74	2.62%	109.19	2.37%
<b>Total Operating Expenses</b>	2,946.69	92.34%	4,922.49	92.25%	3,854.79	91.29%	4,075.45	88.47%
<b>Operating Expenses incurred in Foreign Exchange as % of total Operating Expenses</b>		3.15%		2.05%		2.87%		2.68%
<b>Finance Costs incurred in Foreign Exchange</b>								
Interest Paid on PCFCs Loans	21.81	0.68%	32.25	0.60%	25.69	0.61%	25.81	0.56%
<b>Total Finance Cost</b>	46.00	1.44%	57.60	1.08%	60.53	1.43%	70.05	1.52%
<b>Finance Cost incurred in Foreign Exchange as % of total Finance Cost</b>		47.42%		55.99%		42.44%		36.85%
<b>Current Borrowing incurred in Foreign Exchange</b>	1,392.03	85.06%	1,251.67	92.55%	1,061.86	93.83%	982.11	83.87%
<b>Non-current Borrowing (Term Loans) incurred in Foreign Exchange</b>	239.05	99.73%	246.39	99.63%	164.91	99.14%	75.38	28.87%
<b>Total Borrowing</b>	1,876.26		1,560.85		1,297.97		1,432.08	
<b>Receivables in Foreign Currency</b>	669.55		612.35		622.38		677.99	
<b>Total Receivables</b>	1,033.24		951.62		857.29		886.29	
<b>Receivables in Foreign Currency as % Total Receivables</b>	64.80%		64.35%		72.60%		76.50%	

For further details, see “Financial Statements” on page 162.

While we seek to pass on all losses on account of foreign currency fluctuations to our customers, our ability to foresee future foreign currency fluctuations is limited. As most of our products are priced in foreign currencies, the strengthening of these currencies against the Indian Rupee results in gains and the weakening of these currencies results in losses for our Company. The price list of our products, based on which orders are placed, are generally fixed for a certain period in advance. As an effort to mitigate any significant currency fluctuations, we typically agree to renegotiate/reset prices of our products on a periodic basis including adjustments on account of currency fluctuations beyond a specified range (which may vary between customers, depending on terms negotiated with such customers from time to time). The said permitted adjustments in our price list are generally effected with a prospective effect and may not be adequate to fully set-off the effect of foreign currency fluctuations, which may result, as earlier mentioned, in either losses or gains for our Company.

Under our Forex Risk Management and Hedging Policy, our Forex Risk Hedging Committee (comprising of Gurdeep Soni, our Chairman and Managing Director who is also one of our Promoters, Sanjiv Kashyap, our Chief Financial Officer and Herbert Coenen, who is one of our executive Directors and the managing director of our subsidiary UIG) and our treasury team (Sanjiv Kashyap, our Chief Financial Officer who is assisted by an associate vice president from our corporate controls division) monitor our foreign exchange exposure on a monthly basis in terms of booked exposures (comprising an outstanding foreign currency transaction not as yet settled), economic exposure (in terms of foreign exchange rate movements which are more favourable for our competitors located in other jurisdictions) and local foreign currency exposure (comprising liquidity or cash holding in a currency other than Indian Rupees). While we seek to hedge our foreign currency exchange risk by entering into forward exchange contracts or matching our revenue and expenses currency as much as possible, any action that we may take and any amounts that we spend or invest in order to hedge the risks to our business due to fluctuations in currencies may not adequately hedge against any losses and we cannot assure you of the sufficiency of these procedures or whether the procedures we have in place will be successful in managing our foreign currency exposure. See “Financial Statements – Annexure VI – 42. Financial Risk Management Objectives and Policies” on page 182.

4. ***A failure to comply with financial and other restrictive covenants imposed on us under our financing agreements may cause us to default on these agreements, which may adversely affect our ability to conduct our business and operations.***

As on September 30, 2018, our total long-term (non-current) borrowings from banks, financial institutions and related parties including current maturities of ₹ 118.90 million amounted to ₹ 339.60 million, while our total short term (current) borrowings from banks amounted to ₹ 2,791.63 million. For details of our indebtedness, see “*Financial Indebtedness*” and “*Financial Statements – Annexure VI – 14. Borrowings*” on pages 238 and 190, respectively. Our leverage has several important consequences, including the following:

- a portion of our cash flow from operations will be used towards repayment of debt, which will reduce the availability of cash to fund working capital requirements, capital expenditures, acquisitions and other general corporate purposes;
- our borrowing cost and the existence of encumbrances on a significant portion of our immovable properties may constrain our ability to raise incremental financing in the future, at commercially reasonable terms. For instance, our facilities in Noida, Georgia and one of our facilities in Ludhiana are mortgaged in favour of our lenders, in connection with our secured borrowings. While there have not been any instances in the past of enforcement of security interests owing to an event of default in relation to any properties mortgaged by us in favor of our lenders under any of our financing agreements, which have restricted our ability to operate our business at such locations, in the event of enforcement of an event of default in connection with such secured borrowings (which is not waived or cured) in the future, our ability to continue to operate our business at such locations may be restricted. For details in relation to security interest created in favour of our lenders, see “*Financial Indebtedness*” and “*Financial Statements – Annexure VI – 14. Borrowings*” on pages 238 and 190, respectively; and
- fluctuations in interest rates may affect our cost of borrowing, as all or a substantial part of our borrowings is at floating rates of interest.

In particular, our financing agreements require us to maintain certain financial ratios including debt-equity ratio, and to obtain the consent of, or to intimate, our lenders for certain actions including prepayment of any outstanding borrowings, effecting any change in shareholding or directorship of our Company, raising further loans or incurring any major capital expenditure through our Company or our Subsidiaries, issuance of guarantees by our Company or our Subsidiaries, extending loans or advances to affiliates, or making any material amendments in our Memorandum and Articles of Association or in the constitutional documents of our Subsidiaries. Our failure to comply with financial or restrictive covenants or periodic reporting requirements or to obtain our lenders’ consent to take restricted actions in a timely manner or at all may result in the declaration of an event of default by one or more of our lenders, which may accelerate repayment of the relevant loans or increase applicable interest rates or cause the termination of our credit facilities or lead to the exercise of rights to convert the outstanding amounts into Equity Shares, or trigger the invocation of security under our financing arrangements or cross-defaults under certain of our other financing agreements. For instance, due to an inability to maintain certain financial ratios in the past, we were charged additional interest with effect from March 2009 until July 31, 2009 (excluding for June 2009), under the terms of a foreign currency denominated loan facility sanctioned to our Subsidiary, Uniparts Olsen Inc. (“**UOI**”). However, the defaults were subsequently waived pursuant to an amendment agreement and this facility was repaid in full by UOI and the security was released in April 2013.

An event of default may also affect our ability to raise additional funds or renew maturing borrowings to finance our existing operations and pursue our growth initiatives. The termination of, or declaration or enforcement of default under, any financing agreement (if not waived or cured) may have an adverse effect on our business, financial condition, results of operations and prospects.

5. ***Our Company, its Subsidiaries and certain of our Directors and Promoters are involved in certain legal proceedings, which, if determined adversely, may adversely affect our business and financial condition.***

Our Company, its Subsidiaries and certain of our Directors and Promoters are involved in certain legal proceedings (including central excise and sales tax and commercial disputes) at different levels of adjudication before various courts, tribunals and appellate authorities. In the event of adverse rulings in these proceedings or consequent levy of penalties by other statutory authorities, our Company, Subsidiaries, Directors or Promoters may need to make payments or make provisions for future payments, which may increase expenses and current or contingent liabilities and also adversely affect our reputation.

A summary of the proceedings involving our Company, Subsidiaries, Directors and Promoters is provided below:

S. No.	Name of Entity	Criminal Proceedings	Tax proceedings	Statutory/Regulatory proceedings	Material civil litigation	Aggregate amount involved* (in ₹ million)
1.	<b>Company</b>					
	By the Company	1	-	-	1	87.11
	Against the Company	-	35	1	-	87.44
2.	<b>Promoters</b>					
	By the Promoters	-	-	-	-	-
	Against the Promoters	-	6	-	-	1.76
3.	<b>Directors (Not including Promoters)</b>					
	By the Directors	-	-	-	-	-
	Against the Directors	-	-	-	-	-
	<b>Total</b>	1	41	1	1	176.31

For further details see “*Outstanding Litigation and Material Developments*” on page 254.

6. ***If we are unable to retain and hire Key Managerial Personnel or to maintain good relations with our workforce, our business and financial condition may be adversely affected.***

Our ability to provide high-quality products and services and to manage the complexity of our business depends, in part, on our ability to retain and attract skilled personnel in the areas of management, product engineering, design, manufacture, servicing, sales, IT and finance. Competition for such personnel is intense and the cost of retaining or replacing such personnel may affect our profitability. In addition, our strategies for growth have placed, and are expected to continue to place, increased demands on our management’s and employees’ skills and resources. Our future performance would depend on the continued service of our management, key managerial personnel and our employees, and the loss of any Key Managerial Personnel and the inability to find an adequate replacement may impair our relationship with key customers and our level of technical expertise, which may adversely affect our business, financial condition, results of operations and prospects. In particular, we rely on the experience and industry relationships of our Promoter, Chairman and Managing Director, Gurdeep Soni, Promoter and Vice Chairman, Paramjit Singh Soni, our Director, Herbert Coenen, and our Group Chief Operating Officer, Sudhakar Kolli. Further, while we maintain a directors and officers liability policy, we have not obtained and do not maintain any key man insurance for our employees, Directors or Promoters. Should the involvement of such persons in our business reduce, or should our relationship with these persons deteriorate for any reason in the future, our business, financial condition, results of operations and prospects may be adversely affected.

7. ***We may be subject to work stoppages, strikes or other types of conflicts with our employees or contract workers in the future which may adversely impact our business and financial condition.***

Our manufacturing activities are labour intensive, require our management to undertake significant labour interface, and expose us to the risk of industrial action. Currently, in our U.S. and European operations (where none of our employees are represented by a labour union) and in our Indian operations (where we do not have any recognized trade unions), we have maintained a generally positive working environment.

However, in the past, our Company and our Subsidiaries have lost time on account of strikes or labour unrest in the past. In 2009, at our Noida facility, the factory management decided to withdraw the sale and attendance incentive scheme due to which workers at the factory went on strike from April 16, 2009 to April 24, 2009 and again from May 19, 2009 to June 22, 2009. Negotiations were conducted between the management and the workers in the presence of a magistrate and the Assistant Labour Commissioner, Noida, pursuant to which a settlement was reached and the strike was called off on June 22, 2009. On January 7, 2012, 80 workers at our Visakhapatnam facility went on a strike demanding absorption of 150 contract workers into the Company rolls. The strike was called off on January 13, 2012 pursuant to an agreement entered into by the management and the workers. In September 2014, workers at the Visakhapatnam facility went on a strike. Operations were shut for eight days and the strike was subsequently called off.

Although these incidents were resolved, we cannot ensure that we will not be subject to work stoppages, strikes or other types of conflicts with our employees or contract workers in the future. Further, we cannot ensure that our employees will not unionize in the future. Any such event, at our current facilities or at any new facilities that we may commission or acquire in the future, may adversely affect our ability to operate our business and serve our customers and impair our relationships with key customers and suppliers, which may adversely impact our business and financial condition.

8. ***Availability and cost of raw materials and labour may adversely affect our business, financial condition, results of operations and prospects.***

Our business, financial condition, results of operations and prospects are significantly impacted by the availability and cost of raw materials, particularly steel, power and fuel as well as employee benefit expenses. Steel accounted for 68.77%, 69.85%, 69.08% and 70.36% of our raw material in value terms for the six months ended September 30, 2018 and in Fiscals 2018, 2017 and 2016, respectively. We purchase steel required for our manufacturing facilities in India primarily through spot contracts in the domestic and international markets. Steel used for products manufactured in our facility at Eldridge, Iowa, is primarily sourced in the U.S. from distributors.

While we are not significantly dependent on any single raw material supplier, raw material supply and pricing can be volatile due to a number of factors beyond our control, including global demand and supply, general economic and political conditions, transportation and labour costs, labour unrest, natural disasters, competition, import duties, tariffs and currency exchange rates, and there are uncertainties inherent in estimating such variables, regardless of the methodologies and assumptions that we may use. This volatility in commodity prices (in particular, the cost of steel) can significantly affect our raw material costs. Further, volatility in fuel prices can also affect commodity prices worldwide which may increase our raw material costs.

Our employee benefit expenses accounted for 20.41%, 20.89%, 22.43% and 20.42% of our total revenue for the six months ended September 30, 2018 and in Fiscals 2018, 2017 and 2016, respectively. Our employee benefit expenses are affected by statutorily prescribed minimum wage as well as wage payments following retrenchment. In recent times, labour related costs have been rising in India. For instance, in Fiscal 2018, minimum wages across states in India were increased by a higher than usual margin which in turn affected our costs. In order to retain flexibility and control costs, we appoint independent contractors who, in turn, engage on-site contract labour to perform certain operations. Although we do not engage these labourers directly, in the event of default by any independent contractor, we may be held responsible for any wage payments that must be made to such labourers. If we are required to pay the wages of the contracted employees, our results of operations may be adversely affected.

Further, we depend on a steady supply of power for our manufacturing operations for which we are entirely dependent on the state grids. India suffers from significant energy shortages and power outages, particularly during the summer months, which has resulted in increased power costs in recent years. In the event of unavailability of constant power supply, we will be dependent on our backup power supply which may not be adequate to operate our facilities at full capacity. Further, the cost of backup power may increase in the event of such unavailability of power.

While we typically agree to renegotiate/reset prices of our products to include adjustments beyond a specific range (which may vary between customers), as this is done on a periodic basis and prices are otherwise generally fixed, we may not be able to pass on increase in raw material or labour costs to our customers within this range or at all.

To the extent that we are unable to successfully manage related risks and secure adequate supplies of raw materials and labour on commercially reasonable terms or to pass on price increases to our customers, our profitability may be adversely impacted.

9. ***Our business is impacted by cyclical effects in the global and domestic economy, specifically in the agriculture and CFM sectors, which may have an adverse effect on our business, financial condition, results of operations and prospects.***

Our sales volumes, profitability and liquidity are closely tied to the level of agricultural and CFM activity worldwide, as our customers and end-users operate in the agriculture and CFM sectors and are, therefore, affected by factors that affect the agriculture and CFM sectors, including the levels of investment and production in these specific sectors of the global and domestic economies. The overall contribution of the agriculture and CFM sectors to overall economic growth and stability further underlines the impact caused by the level of activity in the agriculture and CFM sectors.

In particular, the agricultural sector is inherently seasonal and is further impacted by factors including agricultural commodity prices, costs of fertilizers and adverse weather conditions. If we are unable to adequately anticipate and respond to changing conditions affecting the agriculture and CFM sectors and the related cyclical effects on our customers, vendors and on our own operations, our business, financial condition, results of operations and prospects may be adversely affected.

Moreover, the seasonal nature of the agricultural sector as well as other cyclical effects in the economy may, at times, hinder comparison of our financial statements for any given fiscal quarter from our financial statements for any other given fiscal quarter.

10. ***We have significant amounts of short term (current) borrowings. If we experience insufficient cash flows to enable us to fund working capital requirements or to service our short term (current) borrowings, there may be an adverse effect on our business, financial condition, results of operations and prospects.***

Our business requires a high amount of working capital, primarily on account of high inventory levels and trade receivables owing to multiple levels of operations, including backward integrated manufacturing operations as well as forward integrated warehousing. Hence, we have availed a significant amount of short term (current) borrowings to enable us to finance our operating cycle. The details of our inventory and trade receivables, including the number of days for inventory and trade receivables for the six months period ended September 30, 2018 and Fiscals 2018, 2017 and 2016, is as follows:

(in ₹ million, except day-wise data)

Particulars	Six months ended September 30, 2018	Fiscal 2018	Fiscal 2017	Fiscal 2016
Inventory (closing)	3,784.95	3,041.80	2,273.54	2,287.21
Trade receivables	1,453.67	1,156.99	1,008.25	983.03
Inventory days <sup>(1)</sup>	134	131	118	107
Receivables days <sup>(2)</sup>	52	50	52	46

<sup>(1)</sup> Where inventory days = closing inventory / revenue from operations x 365\*

<sup>(2)</sup> Where receivable days = closing receivables / revenue from operations x 365\*

\* 183 for the six months ended September 30, 2018

Our working capital requirements have also increased significantly in recent years due to the general growth in our business, our greater focus on expanding our global service delivery model increased inventories maintained by us due to a growing proportion of Warehouse Sales by us in recent years.

Set forth below are details of our short term (current) borrowings as a percentage of total borrowings and our interest costs on such short term (current) borrowings as a percentage of our profit.

(in ₹ million, except % data)

Particulars	Fiscal 2018	Fiscal 2017	Fiscal 2016
Short term (current) borrowings (working capital)	2,103.56	1,629.10	1,872.09
Total borrowings	2,471.25	1,947.86	2,303.93
Short term (current) borrowings as percentage of total borrowings (%)	85.12%	83.64%	81.26%
Interest costs on short term (current) borrowings	59.32	47.93	49.87
Profit for the year	535.33	265.20	447.12
Interest cost on short term (current) borrowings as a percentage of profit for the year	11.08%	18.07%	11.15%

For details of our short term (current) borrowings, including the key terms of agreements with our lenders for such short term (current) borrowings, see “*Financial Indebtedness*” on page 238.

If a significant customer defaults on or delays payment on any order to which we have devoted significant resources, it may affect our profitability and liquidity and decrease capital resources available to us for other uses, including our obligations under the credit facilities granted to us by our lenders as well as our ability to fund payables to our suppliers, which may further result in reduced availability of raw materials and/or increased raw material costs. If we are unable to finance our working capital needs or to secure other financing, when needed, on acceptable commercial terms, it may adversely affect our business, financial condition, results of operations and prospects.

11. ***We are subject to risks arising from interest rate fluctuations which could adversely affect our results of operations, planned expenditures and cash flows.***

As of September 30, 2018, 89.04% of our indebtedness, excluding bill discounting, was at floating interest rates while 10.96% of our indebtedness was at fixed interest rate or hedged against interest rate risks. For details of our indebtedness, see “*Financial Indebtedness*” and “*Financial Statements – Annexure VI – 14. Borrowings*” on pages 238 and 190, respectively. If the interest rates of our existing or future borrowings increase significantly, our cost of funds will increase. A further increase in interest rates may have an adverse effect on our results of operations and financial condition. While we could consider refinancing the loan or hedging interest rate risks in appropriate cases, there can be no assurance that we will be able to do so on commercially reasonable terms or at all, that our counterparties will perform their obligations, or that these agreements, if entered into, will protect us adequately against interest rate risks. Further, if such arrangements do not protect us adequately against interest rate risks, they would result in higher costs.

12. ***We may face an adverse impact on our sales and earnings as a result of risks associated with our international sales and multi-location operations.***

We have operations and assets located in India, the U.S. and Europe. For the six months period ended September 30, 2018 and Fiscals 2018, 2017 and 2016, our revenue from operations outside India (“**International Sales**”) amounted to ₹ 4,251.28 million, ₹ 6,938.09 million, ₹ 5,721.95 million and ₹ 6,590.59 million, respectively, amounting to 82.44%, 81.99%, 81.38% and 84.55% of our revenue from operations as on these dates, respectively. Further our revenues are significantly dependent on the economic cycles in the U.S. and Europe, and the demand for agricultural and CFM machinery.

A key part of our long-term strategy is to increase our manufacturing, distribution and sales presence in international markets. We are affected by risks inherent in International Sales and operations, including:

- economic cycle and demand for our products in the international markets;
- currency exchange rate fluctuations;
- regional economic or political uncertainty;
- currency exchange controls;
- differing accounting standards and interpretations;
- differing labour regulations;
- differing domestic and foreign customs, tariffs and taxes;
- current and changing regulatory environments;
- difficulty in staffing and managing widespread operations;
- coordinating and interacting with local representatives and counterparties to fully understand local business and regulatory requirements; and
- availability and terms of financing.

Selling products in international markets and maintaining and expanding international operations require significant coordination, capital and resources. Moreover, the length and complexity of our internal production chain make us vulnerable to numerous risks, many of which are beyond our control, which may cause significant interruptions or delays in production or delivery of our products to our customers.

To the extent that we are unable to effectively manage our global operations and risks such as the above (in particular, as we implement our strategy to enter into new markets where we do not have local knowledge and resources), we may be unable to grow or maintain our sales and profitability, or we may be subject to additional unanticipated costs or legal or regulatory action. As a consequence, our business, financial condition, results of operations and prospects may be adversely affected.

13. ***An adverse determination in a significant product liability or performance improvement claim or significant replacement costs may adversely affect our business, financial condition, results of operations and prospects.***

The use of our products, often under extreme conditions, carries an inherent risk of product liability claims arising from personal injury, death or property damage due to equipment failure, work accidents, fire or explosion, if our products are defective or are used incorrectly by our customers (or by their customers, who are the end-users).

We have also entered into warranty agreements with certain key OEM customers, where we have long-term supply arrangements with such customers. To the extent that such OEM customers provide a warranty to their end users and incur warranty costs for non-conformity of their products to agreed specifications or standards, our supply arrangements with our OEM customers typically allow us to review warranty claims in order to determine if the failure was caused by a manufacturing defect in our products. If it is determined that the failure was on account of a manufacturing defect in our products, we are typically required to promptly correct or replace those defective products at our own expense and prepare a written corrective action plan, failing which, we may be required to reimburse our OEM customers at parts acquisition cost, with additives to cover administrative, labour, material and other such costs. We have designed our warranty policy to ensure customer satisfaction. The standard warranty period for our products is 12 to 24 months but, in the case of certain specified types of equipment in which our components are used, may extend to 36 months or longer. We provide product improvement programs to certain customers, whereby, if a particular product or batch of products is not found conforming to the specified quality standards, the product is replaced, followed by a correction program. Where we have not entered into warranty



agreements with certain of our customers, our customers can raise debit notes equal to or more than the selling price of the products that are rejected and physically returned to us or scrapped at the customer's end after our approval.

There is a risk that we may incur higher than expected warranty or performance improvement costs or become aware of a defective or underperforming product. Further, we may be subject to claims arising from alleged, suspected or actual defects in the products that we manufacture, within the warranty periods extended by us, which may require us to conduct product recalls, or we may be required or requested to participate in product recalls conducted by our OEM customers due to alleged, suspected or actual defects in equipment manufactured by them for their own customers. In Fiscal 2015, one of our customers notified us of a warranty claim relating to a specific part supplied by us which had not been properly heat treated and thus allegedly caused defects in the assembly ultimately sold by such customer to its end users. We had outsourced this specific part for heat treatment. We were first notified of a potential claim in August 2014, the amount of which was then unknown. Based upon the data provided to the Company by such customer in 2015, the customer experienced the majority of claims relating to this item in 2012 and 2013. In 2016, we settled this claim for US\$ 1.68 million with such customer and recorded a liability for the full amount in accrued expense. We expected to be reimbursed US\$ 425,000 by the vendor to whom we had outsourced the part for heat treatment. During Fiscal 2017, the vendor reimbursed the Company US\$ 100,000 or ₹ 6.49 million, with the remaining monthly payments coming in the form of credits for services. As of September 30, 2018, the receivable from the vendor was approximately ₹ US \$ 168,000 or ₹ 12.19 million and is included in other receivables. The expense, net of the reimbursement, totalling US\$ 1.26 million or ₹ 82.06 million was recorded in cost of goods sold during Fiscal 2016.

While we maintain insurance coverage, including a product liability insurance covering product recall expenses, product guarantee and financial losses, in keeping with what we believe to be the industry standard, we cannot assure you that we are sufficiently insured against punitive damage awards. In the event that any significant product liability, performance improvement or replacement claims are brought against us, which are not entirely covered by insurance or result in recoveries in excess of our insurance coverage, it may adversely affect our business, financial condition, results of operations and prospects. Further, despite insurance coverage, in the event of any future accident or liability involving our products, our customers may delay or withhold payments to us and/or seek to enforce warranty or performance improvement claims against us, and which in turn may, to that extent, diminish our reputation among our customers, suppliers, lenders, investors and the public, making it difficult for us to operate our business and compete effectively, which may adversely affect our business, financial condition, results of operations and prospects.

14. ***We are currently named in the caution list of the Export Data Processing and Monitoring System of the Reserve Bank of India.***

Exports from India and are required to be conducted in accordance with the Foreign Exchange Management (Export of Goods and Services) Regulations, 2015 and the Foreign Trade Policy (2015 – 2020) issued by the Directorate General of Foreign Trade which functions under the Ministry of Commerce and India, Department of India, Government of India. Exporters are required to realize and repatriate to India the full value of the goods, software and services exported within a stipulated period from the date of export, which is nine months and fifteen months for units located in Special Economic Zones and goods exported to a warehouse established outside India, respectively. Pursuant to the Reserve Bank of India circular no. RBI/2015-16/414 A.P. (DIR Series) Circular No.74 dated May 26, 2016, the procedure for cautioning/de-cautioning exporters was streamlined with the establishment of the Export Data Processing and Monitoring System of the Reserve Bank of India (the “EDPMS”). The EDPMS is an automated processing system where exporters lodge export details through their authorized dealer banks. The names of exporters for whom shipping bills remain open for more than two years are automatically placed in the caution list by the EDPMS and are automatically de-cautioned once related bills are realized and closed or once an extension for realization is granted.

Exporters placed in the caution list are restricted from availing certain facilities such as not being permitted to receive long term export advance (which is otherwise permitted up to a tenor of ten years for exporters having more than three years of satisfactory track record) and not being permitted to remit export claims on application (which is otherwise permitted if the relative export proceeds have already been realized and repatriated to India). In addition, authorised dealer banks of caution listed exporters require the prior approval of the Reserve Bank of India for issuing guarantees for such exporters.

We were included in the caution list on March 1, 2016 on account of shipping bills which were outstanding for more than two years, and as of October 31, 2018, after exercising the option to self-write off our Company has seven shipping bills outstanding in EDPMS while our subsidiary, GFPL has 12 shipping bills outstanding in the EDPMS for periods up to December 31, 2016. We will continue to appear in the EDPMS caution list unless we opt to self-write off the remaining unrealized export bills or if are able to realize our outstanding bills. While we have exercised the option to self-write off in consultation with our authorised dealer banks in the past, we cannot assure you that we

will be able to exercise such and other options in respect of all our unrealized export bills and we cannot assure you that we will be able to realize our outstanding bills in a timely manner or at all.

15. ***Failure or disruption of our IT and/or ERP systems, or cybercrimes or similar disruptions, may adversely affect our business, financial condition, results of operations and prospects.***

We have implemented various information technology (“IT”) and/or enterprise resource planning (“ERP”) solutions to cover key areas of our operations. For instance, we have implemented ERP systems across our operations in the U.S., Germany and our Visakhapatnam, Noida and one of our Ludhiana facilities in India, and we are in the process of implementing ERP at our other Ludhiana facility to consolidate data and other key performance parameters at the global level. Other significant ERP solutions include systems designed to provide data security and to allow for collaboration of information across the network, as well as supply chain solutions to cover critical processes in relation to customers and suppliers across our manufacturing facilities. Further, we are dependent on technology in relation to customer order management and dispatches, production planning and reporting, manufacturing processes on the shop floor, financial accounting and scheduling raw material purchase and shipments. We rely on our IT infrastructure to provide us with connectivity and data backup across our locations and functions. While the ERP solutions that we have implemented have enabled us to improve our working capital cycles, despite an increase in our Warehouse Sales, we can provide no assurance that we will be able to do so in the future.

We believe that we have deployed adequate IT disaster management systems including data backup and retrieval mechanisms, in all our facilities. However, any failure or disruption in the operation of these systems or the loss of data due to such failure or disruption (including due to human error or sabotage) may affect our ability to plan, track, record and analyze work in progress and sales, process financial information, manage our creditors, debtors and hedging positions, or otherwise conduct our normal business operations, which may increase our costs and otherwise adversely affect our business, financial condition, results of operations and prospects.

In addition, our systems and proprietary data stored electronically may be vulnerable to ransomware attacks, computer viruses, cybercrime, computer hacking and similar disruptions from unauthorized tampering. If such unauthorized use of our systems or those of our customers were to occur, data related to our customers, products, product development pipeline, payment systems and other information could be compromised. For instance, in Fiscal 2018, certain of our customers received fraudulent emails from unauthorized third parties requesting them to change their existing payment details for the Company. While we did not suffer any loss as a result of such fraudulent emails, the occurrence of such events could adversely affect our relations with our customers, our business, financial condition and results of operations.

16. ***If we are unable to successfully identify and integrate acquisitions, our growth strategy and prospects may be adversely affected.***

We have in the past relied on inorganic growth as a key part of our growth strategy (including our strategy of examining opportunities for forward integration, expanding into complementary product verticals, new customer acquisition and exploring newer markets where we do not currently have a presence). We may seek to identify and complete acquisitions and investments that meet our strategic and financial return criteria. However, there can be no assurance that we will be able to identify suitable acquisition or investment targets, arrange adequate financing on commercially reasonable terms for planned acquisitions or investments, negotiate commercially reasonable terms for the acquisition of, or investment in, target companies or businesses, integrate their operations with our own, retain key employees and customers critical for the target entity and realize our expectations and strategic objectives from planned acquisitions and investments. We cannot assure you that our acquisitions will prove value accretive.

Strategic acquisitions and investments involve several risks, including the following:

- difficulties in arranging adequate financing (whether debt or equity or a combination thereof) on commercially reasonable terms, to complete our planned investments or acquisitions in the budgeted time, cost and manner;
- difficulties or delays in obtaining lender consents required under our financing agreements, prior to undertaking any planned investments or acquisitions;
- potential assumption of unanticipated liabilities and contingencies, including claims from current or former creditors, customers, suppliers, employees and other third parties;
- potential adverse short-term effects on operating results through increased costs or otherwise;
- unforeseen difficulties in extending disclosure and other internal controls and procedures over financial and other reporting and in performing the required assessment and remediation at the newly acquired business;

- unforeseen difficulties in assimilating the operations, personnel, management information systems and other administrative systems of acquired businesses and in transitioning existing operations, users and customers onto our platforms;
- potential disagreements with strategic partners and collaborators;
- diversion of management time and focus, and managing the realignment of our management resources; and
- possible impairment of relationships with customers, suppliers and employees of acquired businesses as a result of changes in ownership and management;
- unforeseen difficulties in complying with regulatory requirements that may be applicable, in case the target is in a different jurisdiction; and
- difficulties in repatriating funds in case acquisition is made in a jurisdiction which has such restrictions.

For instance, in 2007 we had entered into a joint venture with Kramp Groep B.V. (“**Kramp**”) pursuant to which we had invested in Uniparts Kavee B.V. (“**Kavee**”), primarily for the production of hydraulic cylinders. We sold our entire interest in Kavee to Kramp with effect from April 1, 2012. We incurred a net loss of € 275,001 (₹ 17.76 million on cost basis) on account of this transaction. We believe we have benefited from this transaction due to exposure we gained by our involvement in a new product line as well as industry knowledge of the European markets, although we believe that the long-term focus of Kavee on this product and its customer strategy, including its serviceability, was not aligned to our overall focus and strategy and hence we divested our equity stake in the venture. There can be no assurance that we will be able to succeed in similar ventures in the future.

While we believe that strategic acquisitions can improve our competitiveness and profitability, we may be unable to complete planned acquisitions or investments on schedule or as budgeted or at all, or our due diligence processes may fail to identify all the challenges and liabilities involved in the acquisition or investment. Further, we may be required to expend significant resources and management attention towards such strategic acquisitions which may not fructify. There can be no assurance that any businesses acquired or invested in will perform in accordance with our expectations or that our judgments concerning the value, strengths and weaknesses of businesses acquired or invested in will prove to be correct. Any such risks mentioned above, may reduce our profitability, increase our operating costs, interest and amortization expenses, require us to obtain additional debt and/or equity financing, dilute our goodwill and brand value or otherwise have an adverse effect on our business, financial condition, results of operations and prospects.

17. ***We outsource a portion of our manufacturing processes to certain sub-contractors, which presents numerous risks.***

The processing of some of our intermediate products in India and the U.S. is outsourced. Some of the outsourced processing is undertaken within the premises of our facilities. We depend on the expertise of such sub-contractors and rely on them to provide satisfactory products and levels of service. Thus, our manufacturing and warehousing model presents numerous risks, including the following:

- interruptions to the operations of our sub-contractors due to strikes, lockouts, work stoppages or other forms of labour unrest, breakdown or failure of equipment as well as accidents;
- failure by our sub-contractors to comply with applicable law and the directives of relevant governmental authorities;
- insufficient quality controls or failures in the quality controls of our sub-contractors;
- significant adverse changes in the financial or business conditions of our sub-contractors;
- performance by our sub-contractors below expected levels of output or efficiency;
- the possibility that our competitors will engage our sub-contractors, directly or indirectly, and thereby reduce the manufacturing capacity available to us;
- any inability on our part to renew existing agreements with or find replacements for existing sub-contractors;
- misappropriation of intellectual property by our sub-contractors; and

- sub-standard products impacting our production schedules or adversely impacting our relationships with key customers.

We have in the past been subject to a warranty claim in respect of a component which had been outsourced. In Fiscal 2015, one of our customers notified us of a warranty claim relating to a specific part supplied by us which had not been properly heat treated and thus allegedly caused defects in the assembly ultimately sold by such customer to its end users. We had outsourced this specific part for heat treatment. While we settled this claim with the customer in 2016, a portion of the reimbursement from the vendor is still outstanding. As of September 30, 2018, the receivable from the vendor was approximately US\$ 168,000 or ₹ 12.19 million which is included in other receivables. The expense, net of the reimbursement, totalling US\$ 1.26 million or ₹ 82.06 million was recorded in cost of goods sold during Fiscal 2016.

We cannot assure you that such incidents will not occur in the future or that we will be successful in continuing to receive uninterrupted supply of intermediate products from our sub-contractors at prices acceptable to us, or at all. Any disruption or inefficiencies in the supply chain network may adversely affect our business and results of operations.

18. ***We are subject to various laws and regulations in jurisdictions where we operate, including environmental and health and safety laws and regulations, which may subject us to increased compliance costs, which may in turn result in an adverse effect on our financial condition.***

Our operations are subject to central, state, local and foreign laws and regulations relating to the protection of the environment and occupational health and safety, including those governing the generation, handling, storage, use, management, transportation and disposal of, or exposure to, environmental pollutants or hazardous materials resulting from our manufacturing processes. For instance, we require approvals under the Water (Prevention and Control of Pollution) Act, 1974 and the Air (Prevention and Control of Pollution) Act, 1981, in order to establish and operate our manufacturing facilities in India. Recently, our August 11, 2018 application for abstraction of ground water for use in one of our Noida facility was rejected by the Central Ground Water Board, Ministry of Water Resources for failing to submit a certificate of non-availability of water from the local governmental water supply agency along with our application. While we have re-submitted our application on November 14, 2018, we cannot assure you that we will not be required to submit further documents or fees or that we will be able to obtain this approval.

Our operations, facilities and properties in the United States and Germany are also subject to evolving international, local and federal laws including the Foreign Corrupt Practices Act of 1977 and Foreign Account Tax Compliance Act of 2010, state and local environmental and occupational health and safety laws and regulations, including those governing air emissions, wastewater discharge and the storage and handling of chemicals and hazardous substances.

If we fail to comply with such laws and regulations, we could be subject to significant fines, penalties, costs, liabilities or restrictions on operations, which could negatively affect our financial condition. Regulatory permits required for our operations may also be subject to periodic renewal and, in certain circumstances, modification or revocation. Environmental and occupational health and safety laws and regulations, and the interpretation and enforcement thereof, are subject to change and have tended to become stricter over time, in India and internationally. While we are not aware of any outstanding material claims or obligations, we may incur substantial costs, including clean up or remediation costs, fines and civil or criminal sanctions, and third-party property damage or personal injury claims, as a result of violations of or liabilities under environmental or health and safety laws or noncompliance with permits required at our facilities, which, as a result, may have an adverse effect on our business and financial condition. For instance, we were required to temporarily shut down operations at one of our Noida facilities for a period of approximately one month, pursuant to notices issued by the National Green Tribunal in July 2013 on account of alleged non-compliance with environmental pollution norms. Although the notices were set aside by the National Green Tribunal on September 10, 2013, we cannot assure you that a similar situation will not recur in the future.

As we supply to the North American and other international markets, we are subject to the jurisdiction of the United States and other foreign federal and state regulatory agencies. While we seek to maintain relevant insurance cover and have never had any of our products recalled and are not aware of any current defects in our products that require a recall, we cannot assure you that no such event or circumstance will arise in the future.

In addition, some of our principal customers are agricultural and CFM companies, whose operations are geographically diverse and subject to or affected by a wide array of regulations in the jurisdictions where they operate, such as applicable environmental and health and safety laws and regulations. As a result of changes in regulations and laws relating to such sectors, our customers' operations may be disrupted or curtailed. The cost of compliance with such laws and regulations may also induce certain customers to discontinue or limit certain operations or discourage them from developing new opportunities. As a result of these factors, demand for our

products may be negatively affected by regulations adversely impacting the industries and geographies in which our principal customers operate.

19. ***If more stringent labour laws or other industry standards in India become applicable to us, our profitability may be adversely affected.***

We are subject to a number of stringent labour laws. India has stringent labour legislation that protects the interests of workers, including legislation that sets forth detailed procedures for dispute resolution and employee removal and legislation that imposes financial obligations on employers upon retrenchment and periodic revisions to minimum wage. We are also subject to international, federal, state and local laws and regulations, in all jurisdictions where we have operations, governing our relationships with our employees, including those relating to minimum wage, overtime, working conditions, hiring and firing, non-discrimination, work permits and employee benefits.

If labour laws become more stringent or are more strictly enforced, it may become difficult for us to maintain flexible human resource policies, discharge employees or downsize, any of which could have an adverse effect on our business, results of operations, financial condition and cash flows.

20. ***Failure to obtain or renew necessary regulatory approvals may adversely affect our business and financial condition.***

We are required to obtain various regulatory approvals and registrations for our operations, including consents from the local pollution control boards in India to establish and operate our manufacturing facilities in India, and registrations with the relevant tax and labour authorities in India as well as in the U.S. Failure to obtain and maintain any required approvals and registrations may have an adverse effect on our business, financial condition, results of operations and prospects. Further, our approvals and registrations are subject to numerous conditions (for instance, including periodic reporting or audit requirements), some of which may require us to undertake substantial compliance-related expenditure. Breach or non-compliance with specified conditions may result in the suspension, withdrawal or termination of our approvals and registrations or the imposition of penalties by the relevant authorities. As on the date of this Draft Red Herring Prospectus, our Company has applied for but not received, the following approvals:

Description	Date of Application
Consent to operate under the Air Act, the Water Act and the Hazardous Wastes Act for our Ludhiana facility	October 24, 2018
Application for permission to abstract ground water for industrial use* for our Noida facility	November 14, 2018
Application for obtaining no objection certificate from the Chief Fire Officer, Noida for our Subsidiary GFPL's manufacturing facility at Noida	September 4, 2018

\* Previous application dated August 11, 2018 rejected by the Central Ground Water Board, Ministry of Water Resources.

In addition, we will apply for an approval from the RBI for transfer of Equity Shares held by Meher Soni on a non-repatriation basis pursuant to the Offer for Sale, immediately upon filing of this Draft Red Herring Prospectus with the SEBI.

A suspension, cancellation or refusal to extend our approvals and registrations may require us to cease production at some or all of our manufacturing facilities (or may affect other aspects of our operations), which may have an adverse effect on our business, financial condition, results of operations and prospects.

21. ***Our operational flexibility may be limited in certain respects on account of our obligations under some of our major long-term customer agreements.***

We have entered into long-term customer agreements with some of our key customers. Our pricing terms, payment cycles and permitted adjustments are generally set out in advance in our customer contracts or purchase orders and we also renegotiate/reset prices on a periodic basis including for adjustments beyond a specified range in the event of significant unanticipated changes in, for instance, raw material prices or currency exchange rate fluctuation. Due to committed delivery schedules at a pre-agreed price, we may not be able to adequately adjust our inventory and raw material costs in the event of an unanticipated change or cancellation in orders from our customers and we may, therefore, in certain events, incur additional costs that we are unable to pass through to our customers or be required to write off certain expenses. For instance, in the event of any inability to deliver our products on a timely basis, we may be subject to certain penalties including the requirement to bear additional freight costs (including air freight) under the terms of our arrangements with our customers.

Due to the packaging, transport and labelling laws that apply to our customers in the jurisdictions in which they operate, we are also required to adhere to standards specified by our customers in relation to the delivery of our products to them and any non-conformity with such specifications may result in the rejection of an order even where there is neither any defect in our product nor any delay or deficiency in the delivery. In the event that we are unable to adhere to specified safety, quality and competitive standards and specifications on packaging transport and

labelling, including in relation to on-time delivery or on-site or off-site inspections of our products and facilities or in relation to our committed reporting requirements or the requirement to obtain adequate product liability insurance, we may not be able to continue to enjoy our relationships with such major customers on the same terms over the long-term, or at all. Some of our major long-term customer agreements also require us to obtain the prior approval of our customers before implementing any significant change in manufacturing method, supplier base, factory location, part specification or shipment carrier or prior to sub-contracting or assigning any of our obligations. There can be no assurance that any such consent, if sought by us, will be received within a reasonable time or at all. While various terms of our long-term customer agreements with major customers generally allow us a right of consultation as to difficulties faced by us or provide for certain decisions or adjustments to be made as per mutual agreement, our customers are generally permitted under the terms of such agreements to exercise a high level of discretion. Consequently, we are exposed to the risk that our submissions or requests as to price adjustments or delivery schedules or otherwise may not be agreed to by our customers or our customers may not accede to provide consents sought by us. Any such significant operational constraint may adversely affect our business, financial condition, results of operations and prospects.

Further, under some of our long-term customer agreements, we are required to provide an annual cost reduction in relation to our products. Although we continue to focus on value engineering and process innovation, there can be no assurance that such initiatives will enable us to maintain or improve our margins. Any significant cost reductions that we are not able to compensate for through value engineering and process innovation may, therefore, reduce our profitability.

We are also bound by confidentiality obligations under our non-disclosure agreements with our customers to protect their intellectual property, including in relation to technical data such as product designs, drawings, prototypes and any other intellectual property or proprietary data that may have been shared with us by our customers. While we believe that we have not been in breach of any such confidentiality obligations, an inadvertent breach or any misuse of intellectual property or proprietary data by any of our employees or sub-contractors may expose us to expensive infringement claims and may diminish our goodwill and reputation among our customers, suppliers, lenders, investors and the public, making it difficult for us to operate our business and compete effectively.

22. ***An inability to manage our growth may disrupt our business and reduce our profitability.***

As part of our growth strategy, we are committed to continuing to diversify our product offerings, customer base and geographic footprint and minimizing our exposure to individual market and segment declines. Our growth requires us to continuously invest in our operations, evolve and improve our operational, financial and internal controls and administrative infrastructure. In particular, this significantly increases the challenges involved in:

- maintaining high levels of customer satisfaction;
- acquiring new customers and increasing/maintaining contribution from existing customers;
- maintaining the quality and precision level of our products;
- preserving a uniform work culture and environment across our sites and maintaining and improving operational synergies between our sites, including our international locations;
- arranging for adequate financial resources (whether in the form of debt or equity or a combination thereof) for planned improvements and expansions;
- obtaining required lender consents;
- managing our relations with our labour force and successfully resolving any labour disputes that may arise from time to time; and
- recruiting, training and retaining sufficient skilled technical, marketing and management personnel.

An inability to manage our growth, including as a result of a failure to adequately respond to any such challenges, risks or uncertainties, may disrupt our business and reduce our profitability.

23. ***Our reliance on third parties for certain aspects of our business, including raw material suppliers, transporters of our raw materials and products and logistic / warehouse service providers, exposes us to certain risks.***

We rely on third parties for the supply of raw materials, components, contract labour and power required for the manufacture of our products, as well as for performance of certain processes and services carried out at our manufacturing, warehousing and office premises including waste management and facility management functions. Our ability to identify and build relationships with reliable vendors worldwide contributes to our growth and our

successful management of our inventory as well as other aspects of our operations. Although we have an in-house vendor rating process, we cannot assure you that this process entirely eliminates the risk of un-reliable vendors. Our raw material and component suppliers may fail to consistently deliver products of acceptable quality and within stipulated schedules, or the contractors to whom we have outsourced certain processes and services at our manufacturing, warehousing or office premises may not fulfill specified performance standards, which may adversely affect our operations. We may be required to replace a vendor if its products or services do not meet our safety, quality or performance standards or if a vendor should unexpectedly discontinue operations due to reasons beyond its or our control (including financing constraints caused by credit market conditions).

Factors such as the financial instability of suppliers, vendors' noncompliance with applicable laws, trade restrictions, labour disputes, currency fluctuations, changes in tariff or import policies, severe weather, political uncertainty, terrorist attacks and transport capacity and cost may disrupt our supply chains, which may result in increased costs or delivery delays. Further, increase in competition and/or our competitors having established operations and long-term relationships with suppliers may see us facing challenges to secure adequate supply of raw materials or may increase our overall cost of raw materials. Therefore, there is no assurance that third party suppliers will be able to meet their contractual commitments to us, or that we will not be required to incur additional costs to remedy any deficiencies in their services or to obtain alternative sources of supply in the event that our contracted suppliers should default or be delayed in their performance. A significant disruption in supply of raw material, contract labour, power or third party services for our warehousing operations may, in turn, disrupt our operations and adversely affect our inventory management, business and financial condition, at least until alternative sources of supply of goods and services are arranged.

We also use, and intend to continue to use, third party transporters for the supply of our raw materials and for deliveries of our products to our customers. Increased transportation costs as well as interruptions due to strikes by members of truckers' unions or shipping delays or adverse weather conditions or inadequate transport infrastructure may, to the extent that our losses are not covered by insurance, adversely affect the timely receipt of our raw materials as well as products, resulting in an adverse impact on our business, financial condition, results of operations and prospects.

24. ***Activities involving our manufacturing process can be dangerous and can cause injury to people or property in certain circumstances. A significant disruption at any of our manufacturing facilities may adversely affect our production schedules, costs, sales and ability to meet customer demand.***

Our business involves complex manufacturing processes that can be dangerous to our employees. Although we employ safety procedures, including providing safety equipment on the shop floor, in the operation of our facilities and maintain what we believe to be adequate insurance, there is a risk that an accident or death may occur in any of our facilities. An accident may result in destruction of property or equipment, environmental damage, manufacturing or delivery delays, or may lead to suspension of our operations and/or imposition of liabilities. Any such accident may result in litigation, the outcome of which is difficult to assess or quantify, and the cost to defend litigation can be significant. As a result, the costs to defend any action or the potential liability resulting from any such accident or death or arising out of any other litigation, and any negative publicity associated therewith, may have a negative effect on our business, financial condition, results of operations and prospects. While we maintain legally mandated insurance policies such as accident and medical insurance policies for our employees and a public liability insurance, we cannot assure you that the coverage under such policies will be sufficient to cover loss sustained or that an affected employee or third party will not additionally seek legal recourse against us.

In particular, if operations at our manufacturing facilities were to be disrupted as a result of any significant workplace accident, equipment failure, natural disaster, power outage, fire, explosion, terrorism, adverse weather conditions, labour dispute, obsolescence or other reasons, our financial performance may be adversely affected as a result of our inability to meet customer demand or committed delivery schedules for our products. For instance, in August 2005, a warehouse owned by UUL located in Augusta, Georgia collapsed during construction. During this period, warehousing operations of UUL were carried out from a public warehouse. We incurred warehousing charges for use of the public warehouse as well as additional legal fees in this regard. Further, in October 2013, a fire affected the heat treatment area of our Visakhapatnam facility. The delivery schedule to our customers during the period from November 2013 to March 2014 was adhered to by outsourcing the heat treatment process to third parties and supplies to our customers were fulfilled without any stoppages. Our Company incurred expenses of ₹ 13.06 million towards outsourcing of the heat treatment process on account of this fire and also incurred additional freight cost to meet our customers' delivery schedules. Since that time we have completed repairs at the Visakhapatnam facility heat treatment area.

Interruptions in production may also increase our costs and reduce our sales, and may require us to make substantial capital expenditures to remedy the situation or to defend litigation that we may become involved in as a result, which may negatively affect our profitability, business, financial condition, results of operations and prospects.

25. ***The discontinuation or loss of business, with respect to a particular OHV model for which we are a significant supplier could reduce our sales and profitability.***

Purchase orders from our customers generally provide for the supply of a customer's periodic requirements for components for a particular OHV model, rather than for the supply of a customer's requirements for components for the life of a particular OHV model or for the purchase of a specific quantity of components. Therefore, in the event that a particular OHV model is discontinued by our customer or demand for a particular OHV model is significantly less than anticipated by the relevant customer, it may adversely affect our inventory management and, in turn, our sales and profitability could be adversely affected. In addition, it is possible that our customers could elect to internally manufacture components that are currently produced by outside suppliers, such as us, or source the products from an alternate supplier.

The reduction in demand for, and sales of, our products for any such reason may have a consequent adverse impact on our business, financial condition, results of operations and prospects, particularly to the extent that we are unable to sell or appropriately dispose of the inventory that we maintain or are required to continue maintaining for any OHV models that are discontinued by our customers (for which we are not fully compensated by them) or for which there is no longer any significant demand in the markets in which our customers operate.

26. ***We face competition in all our product lines, including from competitors that may have greater financial and marketing resources. Failure to compete effectively may have an adverse impact on our business, financial condition, results of operations and prospects.***

Our domestic and international operations are subject to competitive pressures in all our product lines. We compete directly and indirectly with other manufacturers and suppliers of engineered components to OEMs (including OEMs that produce such components for their own use) and in the aftermarket. We compete on the performance, functionality, customer service and support, availability, price and brand recognition of our products. Increased competition may force us to improve our process, technical, product and service capabilities and / or lower our prices or result in loss of customers, which may adversely affect our profitability and market share, in turn, affecting our business, financial condition, results of operations and prospects.

The greater financial, marketing, technological and other resources of certain of our competitors may enable them to commit larger amounts of capital in response to changing market conditions, or to achieve substantially more market penetration in certain segments of those markets in which we operate or to anticipate the course of market developments and trends more effectively than we do and to develop product and process innovations and capabilities that may put us at a disadvantage. We may also face competition from new entrants in the market as well as aggressive pricing and marketing strategies by other manufacturers trying to gain market share. Further, competitors in other countries may be more competitive in terms of pricing due to lower labour and other costs. Moreover, some of the other component manufacturers that we compete with may have the benefit of greater consolidation and integration (for instance, including captive consumption of components produced by them) or greater diversification (in terms of other businesses that are not exposed to the economic and financial pressures that affect the OHV components manufacturing business or the agriculture and CFM segments) or lower costs in relation to manufacturing structures and lower costs of transportation in our key markets.

There are several competing producers of varying size and in various geographical markets. Therefore, as the parameters of competition in this business are less firmly established than in certain other types of businesses, we believe that it is difficult to predict how the competitive landscape of our business will develop over the long term. General competitive factors in the market, which may affect the level of competition over the short and medium term, include vulnerability to overall macroeconomic factors, time to market, product features, design, quality, price, delivery, warranty, general customer experience and relationships between producers and their customers.

27. ***We have compounded delayed filing of certain records with the Reserve Bank of India in the past.***

Our Company received a letter dated August 21, 2014 from the Reserve Bank of India ("RBI") stating that four remittance transactions undertaken by our Company under the overseas direct investment mechanism in relation to Uniparts USA Limited ("UUL") were reported with inordinate delay on June 4, 2014, June 2, 2014 and June 12, 2014 (for two transactions). There was also a delay in reporting the acquisition of UOI by UUL. The RBI in its letter stated that such delay was in contravention of regulation 6(2)(vi) of RBI notification no. FEMA120/RB-2004 dated July 7, 2004, as amended, and advised our Company to compound the aforementioned delay. We have subsequently compounded this delay pursuant to an order dated March 16, 2015 of the RBI and payment of ₹ 2.53 million. While we believe that there have been no material non-compliance in the past, and that material information required for investors to make their investment decision in this Offer has been disclosed in this Draft Red Herring Prospectus, we cannot assure you that we will not be penalized for delay in regulatory filings in the future.

28. ***Our dependence on our Subsidiary, UOI, exposes us to significant risks.***



We currently conduct a significant portion of our operations, especially in the U.S., through our 100% Subsidiary, UOI, which contributed 38.61%, 37.86%, 37.96% and 38.67% of our revenue from operations as of September 30, 2018 and Fiscals 2018, 2017 and 2016, respectively. We, therefore, rely on UOI for expanding our market share and business in the U.S for U.S. produced products and products from our Indian manufacturing facilities, and consequently our revenues, our free cash flows, investment income, financing proceeds, dividends and other permitted payments. Further, a significant diminution in the value of our investment in UOI may have an adverse effect on our financial condition, results of operations and prospects.

As UOI is a separate and distinct legal entity, it has no obligation to pay dividends and may be restricted from doing so by law or contract, including applicable laws, charter provisions and the terms of its financing arrangements. We cannot assure you that UOI will generate sufficient profits and cash flows, or otherwise be able to pay dividends to us in the future. In addition, our financial condition may be adversely affected, should our equity stake in UOI be diluted or if it ceases to be our subsidiary.

29. ***If we fail to maintain an effective system of internal controls, we may not be able to successfully manage, or accurately report, our financial risks.***

Effective internal controls are necessary for us to prepare reliable financial reports and effectively avoid fraud. Moreover, any internal controls that we have or may implement, or our level of compliance with such controls, may deteriorate over time due to evolving business conditions.

There can be no assurance that deficiencies in our internal controls will not arise in the future, or that we will be able to implement, and continue to maintain, adequate measures to rectify or mitigate any such deficiencies in our internal controls. Any inability on our part to adequately detect, rectify or mitigate any such deficiencies in our internal controls may adversely impact our ability to accurately report, or successfully manage, our financial risks, and to avoid fraud.

30. ***Our insurance coverage may not adequately protect us from all material risks and liabilities.***

Our business, including our manufacturing operations in particular, carry an inherent risk of exposure to substantial liability for product liability, property damage, personal injury or death, environmental pollution or other damage. We maintain insurance coverage in respect of our buildings, plant and machineries, fixtures and fittings, other equipment and inventories, covering losses due to fire (including standard fire and allied perils) and burglary, as well as fidelity guarantee and money insurance policies. In addition, we cover our employees under group accident and medical insurance programs, except in respect of locations where our workforce is covered under the ESI scheme. However, our insurance is subject to customary deductibles, exclusions and limits which may prevent us from fully recovering our losses, or our insurance may not be adequate to cover our liabilities. There may also be certain types of risks for which we are not covered. Further, there is no assurance that insurance will be generally available in the future or, if available, that the premiums will be commercially justifiable. If we incur substantial liability which is not covered by insurance or exceed policy limits, our business, financial condition, results of operations and prospects may be adversely affected.

31. ***Our strategy to enhance engineering, product innovation and design competence may not yield the expected benefits.***

We focus on process and product innovation and value engineering solutions in order to meet the requirements of a wider range of OHVs, geographies, applications and other customer specifications, so as to strengthen and diversify our product portfolio and enhance our profit margins. Towards this objective, we continue to develop our in-house value engineering and process innovation capabilities as well as exploring opportunities for collaboration and inorganic growth as well as by continuing to work closely with our customers to upgrade and customize our products.

In our experience, the agriculture and CFM sectors have been tending towards increased mechanization, especially in recent years. Our customers, especially global OEMs, are increasingly developing larger, more technically complex products, projects, processes and applications. To meet our customers' requirements, we must regularly update existing technology or know-how or acquire or develop new technology or know-how. In addition, shifts in customer demand can render existing technologies and machinery obsolete, requiring additional capital expenditures and/or write-downs of assets. Our failure to anticipate and adequately respond to evolving technical and technological specifications and market trends may adversely affect our business, financial condition, results of operations and prospects.

Planned product upgrades may be subject to unanticipated delays or our competitors' products may be more effective or innovative and/or less expensive or may garner larger market share due to other reasons beyond our present knowledge or control, thus yielding lower sales and profits relative to our expectations.

32. ***Contingent liabilities which have not been provided for may adversely affect our financial condition.***

As of September 30, 2018, our capital and other commitments (contingent liabilities) not provided for in our Restated Financial Statements are as follows:

*(in ₹ million)*

Particulars	As of September 30, 2018
<b>Claims against the company not acknowledged as debt:</b>	
Sales tax matters	2.34
Service tax matters	0.23
Custom matters	1.60
Excise matters	0.94
Labour matters	Not Ascertainable
<b>Sales tax liability against pending forms</b>	<b>0.74</b>
<b>Income tax demands</b>	<b>0.36</b>
<b>Others</b>	
Guarantees given on behalf of the company by the banks:	
Sales tax matters	0.03
Pollution Control Board	0.02
Excise matters	0.50
Gas connections	2.68
<b>SBLC (Stand By Letter of Credit) for wholly owned Subsidiaries</b>	<b>9.25</b>
<b>Bond cum Legal Undertaking to Andhra Pradesh Special Economic Zone and Noida Special Economic Zone</b>	<b>1,699.73</b>

\* In addition estimated amount of contracts remaining to be executed on capital accounts and not provided for (net of advances) is ₹ 120.24 million. For details of our capital and other commitments see "Financial Statements - Annexure VI: Notes to Restated Consolidated Financial Information – 37. Capital and other commitments" on page 217.

Our ascertainable contingent liabilities constitute 44.24% of our net worth as on September 30, 2018. If these contingent liabilities materialize, fully or partly, our financial condition may be adversely affected. For details, see "Financial Statements" and "Outstanding Litigation and Material Developments" on pages 162 and 254, respectively.

33. ***Certain of our immovable properties in India and overseas, and machinery are leased by us. If we are unable to renew existing leases or relocate our operations on commercially reasonable terms, there may be an adverse effect on our business, financial condition and operations.***

Certain of our manufacturing and warehousing facilities in India and overseas are held by us on leasehold basis, from third parties, related parties and certain Government authorities on certain terms and conditions. For instance, in relation to our leased premises in Ludhiana, the Promoters are required to maintain 51% shareholding. Further, the leases for these premises require periodic renewal and are subject to periodic escalation of lease payments. Some of our leased premises in Noida, Ludhiana and in the United States have lessor lock-in periods ranging from two to five years which is shorter than the time period for which we expect to utilize these premises and therefore in the event of any such termination we may be required to either re-negotiate terms or shift our operations to alternate locations on expiry. As on March 31, 2018, 2017 and 2016, our total lease rentals paid under leases relating to land, building premises and machinery amounted to ₹ 162.50 million, ₹ 164.42 million and ₹ 126.14 million, respectively.

If we are unable to renew certain or all of these leases on commercially reasonable terms, we may suffer a disruption in our operations or be unable to continue to operate from those locations in the future (and may, to that extent, need to revise our raw material sourcing, product manufacturing and raw material and product inventory schedules and/or incur significant costs to relocate or expand our operations elsewhere in order to continue to honour our commitments to our customers). In addition, the terms of certain of our leases require us (as the lessee) to incur certain repair and maintenance costs from time to time and to bear utility charges, and include conditions which may restrict our operational flexibility in certain respects, for instance, requiring us to obtain the lessor's prior consent for certain actions (including making significant structural alterations to the factory building, which may be required if we were to undertake a significant expansion in the future, or for undertaking a corporate restructuring or to sublet, transfer, assign, charge or mortgage such properties).

For details of our immovable properties, see "Our Business – Immovable Properties" on page 131.

34. ***Some of the loans availed by us and our Subsidiaries may be recalled by the lenders at any time, which may lead to default in terms of such financing agreements.***

As on September 30, 2018, our loans from banks, which are repayable on demand, amounted to ₹ 3,131.22 million and are liable to be recalled by the respective lenders at any time. Any failure to service such indebtedness, comply with a requirement to obtain lender consent or otherwise perform such obligations under such financing agreements

may lead to a termination of one or more of our credit facilities or penalties and acceleration of amounts due under such credit facilities, which may adversely affect our business, financial condition, results of operations and prospects.

35. ***Three of our manufacturing facilities are operated on industrial land allotted to us by industrial development corporations. Failure to comply with the conditions of use of such land could result in an adverse impact on our business and financial condition.***

We have five manufacturing facilities in India, of which three of our facilities (both of our facilities in Ludhiana and one of our facilities in Noida) are operated on industrial land allotted to us by state owned industrial development corporations, specifically the Punjab Small Industries & Export Corporation Limited in Punjab and the New Okhla Industrial Development Authority in Noida (together the “IDCs”). Under the terms of the lease by which land was allotted to us, we are required to comply with certain ongoing conditions, including achieving the investment commitment set out in the project report, adhering to the timelines for completion of setting up of the manufacturing facility, and commencement of manufacturing activity. If we fail to meet any such conditions, we may be required to incur additional liability. Further, according to the various statutory rules under which each of the IDCs function, they also retain the power to cancel allotment of land in the event of breach of any rules of allotment. Cancellation of the land allotted by way of lease to us could have an impact on our financial condition which could adversely impact our results of operations and financial condition.

36. ***There are several restrictions on SEZs and underlying SEZ land in India, which may adversely affect our Visakhapatnam facility and one of our Noida facilities.***

One of our Noida facilities and our Visakhapatnam facility are situated in special economic zones (“SEZs”) and our leases for these premises, therefore, restrict our ability to use these locations to manufacture products for domestic sales (i.e., other than for exports) or to undertake any new line of business. Under the prevailing law governing SEZs in India, the land area in an SEZ may be demarcated into a processing area for setting up units for manufacture of products or provision of services, or an area exclusively for trading or warehousing purposes, or a non-processing area for other activities. The lease period for space in the processing area or the free trade and warehousing zone within an SEZ has to be for a minimum period of five years. Moreover, the developer cannot remove goods from the SEZ to the domestic tariff area (“DTA”) without permission from the relevant authority and, where applicable, certain duties are to be paid for clearance of goods in DTA. There are also certain restrictions on transfer of SEZ units, including the requirement to obtain the approval of the relevant authority for any proposed sale or transfer of an SEZ unit and a lock-in period in terms of the SEZ land having been leased for a minimum period of five years and a minimum operating history of at least two years from commencement of operations of the SEZ unit proposed to be sold or transferred.

Further, the approvals received by us to develop, operate and maintain the SEZs are subject to us fulfilling certain conditions, including compliance with environmental safety standards, applicable standards relating to planning, sewage disposal, pollution control, labour laws and execution of certain guarantees. In the event we are unable to comply with the restrictions under the laws governing SEZs in India, our rights to use our units demarcated as SEZs may be suspended or withdrawn and the guarantees provided by us may be invoked against us as a penalty, which may in turn adversely affect our business, financial condition, results of operations and prospects.

In the event that regulatory authorities allege non-compliance of the Special Economic Zones Rules, 2006 and subject us to regulatory action for any reason in the future, we may be subject to consequences including penalties or seizure of land. Any such action or any changes to the SEZ regime may adversely affect our business, financial condition, results of operations and prospects.

37. ***We are entitled to certain tax benefits under the Special Economic Zones Act, 2005 (“SEZ Act”) and other fiscal statutes. These tax benefits are available for a definite period of time, which, on expiry or if withdrawn prematurely, may adversely affect our business, financial condition, results of operations and prospects.***

We are entitled to claim certain direct tax exemptions or reimbursements on account of parts of our manufacturing facility in Noida and the whole of our manufacturing facility in Visakhapatnam being situated in SEZs. For instance, we are entitled to exemptions from (or refunds on account of) the following duties and levies:

- duty on import/domestic procurement of goods for development, operation and maintenance of SEZ operations;
- payment of excise duty for goods brought from a DTA into the SEZ for its authorized operations;
- payment of central sales tax, value added tax and service tax, which is applicable in case of petroleum products; and

- payment of income tax for a period of 15 years from commencement of production at the SEZ, as follows:
  - 100% deduction of income from profits and gains from exports for the first five years;
  - 50% deduction of income from profits and gains from exports for the next five years;
  - 50% deduction of income from profits and gains from exports, which have been credited to the reserve account to be utilized for the purpose of the said business for the next five years.

For further details, see “*Statement of Special Tax Benefits*” on page 84.

Our profitability will be affected to the extent that such benefits are not available beyond the periods currently contemplated. Our profitability may be further affected in the future if any benefit under the statute is reduced or withdrawn prematurely or if we are subject to any dispute with the tax authorities in relation to these benefits. Further, under the SEZ Act, we are required to maintain positive net foreign exchange earning that is to be calculated cumulatively for a period of five years from the commencement of our operations carried out from the SEZs. If we fail to maintain positive net foreign exchange earnings, we would be subject to penalties as prescribed under the Foreign Trade (Development and Regulation) Act, 1992, including penalties of up to five times the value of the goods in respect of which contravention is made. In the event that any adverse development in the law or the manner of its implementation affect our ability to benefit from these tax incentives, our business, financial condition, results of operations and prospects may be adversely affected.

38. ***Our Promoters have provided personal guarantees for a significant portion of our borrowings and collateral to secure certain of our loans. Our business, financial condition, results of operations and prospects may be adversely affected by the revocation of all or any of the personal guarantees provided by our Promoters in connection with our Company’s borrowings.***

Our Promoters have provided personal guarantees for a significant portion of our borrowings and collateral to secure certain of our loans. See “*Financial Statements – Annexure VI – 14. Borrowings*” on page 190. If any of these guarantees are revoked or if such collateral is proved insufficient, our lenders may require alternative guarantees or collateral or cancellation of such facilities, entailing repayment of amounts outstanding under such facilities. If we are unable to procure alternative guarantees satisfactory to our lenders, we may need to seek alternative sources of capital, which may not be available to us at commercially reasonable terms or at all, or to agree to more onerous terms under our financing agreements, which may limit our operational flexibility. Accordingly, our business, financial condition, results of operations and prospects may be adversely affected by the revocation of all or any of the personal guarantees provided by our Promoters in connection with our Company’s borrowings.

39. ***We have entered, and will continue to enter, into related party transactions which may involve conflicts of interest. Further, our Promoters and Directors have interests in us other than reimbursement of expenses incurred and normal remuneration or benefits and in one of our Group Companies which is authorised to engage in the same line of business as our Company.***

We have, in the ordinary course of our business, entered into transactions with certain related parties. We have in the past and may in the future purchase goods and samples from and sell goods to related parties. In addition, our Registered Office is leased by us from a member of our Promoter Group, Soni Holdings (Partnership Firm).

Further, our Promoters (who are also Directors of our Company), Gurdeep Soni and Paramjit Singh Soni, receive remuneration and benefits from our Subsidiaries GFPL and UUL, respectively. One of our Directors, Herbert Coenen, receives remuneration and benefits as managing director of our Subsidiary, UIG and may be deemed to be interested to the extent that he has been granted ESOPs pursuant to ESOP 2007. Our Promoters and Directors are also interested in relation to lease rentals paid by the Company and in relation to certain property acquired by the Company. For details, see “*Capital Structure*”, “*History and Certain Other Corporate Matters*”, “*Our Management*”, “*Our Promoters and Promoter Group*” and “*Financial Statements*” on pages 64, 136, 143, 158 and 162, respectively.

While, in our view, all such related party transactions that we have entered into are conducted on an arm’s length basis, we cannot assure you that we could not have achieved more favourable terms had such arrangements not been entered into with related parties. Further, we cannot assure you that these or any future related party transactions that we may enter into, individually or in the aggregate, will not have an adverse effect on our business, financial condition, results of operations and prospects.

Further, our Group Company SKG Engineering Private Limited (which is also a member of our Promoter Group) is authorised pursuant to its memorandum of association to engage in businesses similar to that of our Company. Although it is presently not engaged in business similar to that of our Company, we have not entered into any non-compete agreement with our Group Company or any member of our Promoter Group and we cannot assure you that

we will not have a potential conflict of interest with our Group Company. For details, see “*Our Promoters and Promoter Group*” on page 158.

40. ***Grants of stock options under our employee stock option plan may result in a charge to our profit and loss account and, to that extent, reduce our profitability and financial condition.***

As on the date of this Draft Red Herring Prospectus, 936,488 stock options have been granted to eligible employees and are outstanding under the Uniparts Employee Stock Option Plan-2007 (“**ESOP 2007**”).

Under Ind AS, the grant of employee stock options results in a charge to our Company’s profit and loss account equal to the intrinsic value (which will amortize over the vesting period of these stock options) based on the difference between the fair value of our Equity Shares determined at the date of grant and the exercise price. Our expenses related to ESOP 2007 amounted to ₹ 0.29 million for Fiscal 2018 and an aggregate of ₹ 2.55 million for the period Fiscals 2016 to 2018.

41. ***Our quarterly results may fluctuate significantly due to seasonality which could have a negative effect on the price of our Equity Shares.***

Our quarterly results of operations may fluctuate significantly as a result of a variety of factors, including the seasonal nature of the sectors in which we operate. For instance, a significant portion of our operating profit and cash flows have historically been realized during the first and fourth quarters of each year, primarily due to seasonality and weather conditions. As a result, our financial statements for consecutive quarters may not be directly comparable with each other. Moreover, any significant disruption in our operations or other factors that result in a significant shortfall compared with our expectations for the first and fourth quarters could, consequently, result in a significant shortfall in sales and operating cash flows for the full year.

42. ***We may not be able to adequately protect our intellectual property rights, including the use of the “Uniparts” name and associated logo, which could harm our competitiveness.***

We believe that the use of our name and logo is vital to our competitiveness and success and for us to attract and retain our clients and business partners. Any improper use or infringement by any party could adversely affect our business, financial condition and results of operations. We cannot assure you that the measures we have taken will be sufficient to prevent any misappropriation of our intellectual property.

Enforcement of any intellectual property rights could be time consuming and costly. We may not be able to establish our rights to such intellectual property in the absence of relevant registrations and accordingly may not be able to take appropriate action or prevent the use of such name or logo by third parties. In the event that the measures we take do not adequately safeguard our intellectual property rights, we could suffer losses due to competing offerings of services that exploit our name and logo.

We may also be subject to claims for breach of intellectual property by third parties in the event we are unable to secure adequate protection in relation to our name and logo. UIG, our Subsidiary in Germany, received a letter dated June 18, 2015 from a representative of Unipart Group Limited (“**UGL**”), which is a third party, requiring us to cease using the mark “**UNIPART**” in Europe claiming that they hold registrations for the term “**Unipart**” under various classes in Europe as Community Trade Marks. While we have sought to resolve the dispute amicably, we have not received any communication from UGL since September 2017. However, we cannot assure you we will be successful in reaching an amicable settlement or that UGL will not initiate legal proceedings against us in the future.

43. ***We have sustained negative cash flows from operations in the past and may experience earnings declines or operating losses in the future.***

We have sustained negative net cash flow from operating activities for the six months period ended September 30, 2018 and Fiscal 2018, largely due to increase in inventory (including from Warehouse Sales) which led to an increase in our working capital requirements necessitated by growth in our business during these periods as detailed below:

- Our net cash used in operating activities for the six months ending September 30, 2018 was ₹ 207.57 million primarily due to increase in working capital by ₹ 722.27 million. The working capital increased because of the increase in inventory by ₹ 743.15 million due to increase in Warehouse Sales.
- Our net cash used in operating activities in Fiscal 2018 was ₹ 56.26 million primarily due to increase in working capital by ₹ 776.16 million consequent to the increase in inventory by ₹ 768.26 million. This increase in working capital requirements was consistent with the growth in our business during Fiscal 2018.

We cannot assure you that we can sustain profitability or avoid losses in the future. We expect that our operating expenses will increase in the future, as a result of our proposed projects. As a result, any decrease or delay in generating additional income, including sales revenues, could result in substantial operating losses.

For further details, see “*Financial Statements*” on page 162.

44. ***There can be no assurance that the objects of the Offer will be achieved within the time frame expected or at all, or that the deployment of the Net Proceeds in the manner intended by us will result in any increase in the value of your investment. Further, the plan for deployment of the Net Proceeds has not been appraised by any bank or financial institution.***

Our Company intends to use approximately ₹ 750 million of the Net Proceeds to prepay or repay certain debt of our Company, subject to the relevant prepayment conditions.

The details of the debt identified to be repaid using the Net Proceeds have been disclosed in the section titled “*Objects of the Offer*” on page 76. The use of the Net Proceeds for purposes identified by our management may not result in actual growth of our business, increased profitability or an increase in the value of your investment.

Further, the plans for deployment of the Net Proceeds are in accordance with our own estimates and have not been appraised by any bank, financial institution or any other external agency. Our Company may have to revise its management estimates from time to time on account of various factors beyond its control, such as market conditions, competitive environment, and interest or exchange rate fluctuations and consequently its requirements may change.

45. ***Any variation in the utilisation of the Net Proceeds as disclosed in this Draft Red Herring Prospectus is subject to certain compliance requirements, including prior Shareholders’ approval.***

We propose to utilise a substantial portion of the Net Proceeds to prepay or repay certain debt of our Company. For further details of the proposed objects of the Offer, see “*Objects of the Offer*” on page 76. We currently cannot determine if we will require the Net Proceeds to meet any other expenditure or fund any exigencies arising out of our competitive environment, business conditions, economic conditions or other factors beyond our control. In accordance with Section 27 of the Companies Act, 2013, and Regulation 59 read with Schedule XX of the SEBI ICDR Regulations, we cannot vary the utilisation of the Net Proceeds as disclosed in this Draft Red Herring Prospectus without obtaining the Shareholders’ approval through a special resolution. In the event of any such circumstances that require us to vary the disclosed utilisation of the Net Proceeds, we may not be able to obtain the Shareholders’ approval in a timely manner, or at all. Further, in compliance with the Companies Act, 2013, any dissenting shareholders may be required to be provided with an exit right, on terms and conditions specified under Schedule XX of the SEBI ICDR Regulations and applicable law. Any delay or inability in obtaining such Shareholders’ approval or inability to provide an exit to dissenting shareholders may adversely affect our business.

Accordingly, we may not be able to vary the objects of the Offer to use unutilised proceeds of the Offer, if any, for any purpose other than as disclosed in this Draft Red Herring Prospectus even if such variation is in the interest of our Company. This may restrict our ability to respond to any change in our business or financial condition by redeploying any unutilised portion of the Net Proceeds, which may adversely affect our business.

46. ***This Draft Red Herring Prospectus contains information from industry sources including a report commissioned from CRISIL Limited. Prospective investors are advised not to place undue reliance on such information.***

We have commissioned the CRISIL Report titled “*Global market assessment of 3PL and PMP products in Agriculture and Construction Equipments*” dated November 29, 2018 pursuant to an engagement between CRISIL Limited and our Company. The report uses certain methodologies for market sizing and forecasting of the industry and is subject to certain disclaimers set out in “*Presentation of Financial, Industry and Market Data*” on page 14. Neither we, nor the BRLMs, their associates or affiliates, nor any other person connected with the Offer have verified the information provided by CRISIL Limited, F&S and other industry sources.

CRISIL Limited has advised that, while it has taken due care and caution in preparing the CRISIL Report based on the information obtained by it from sources which it considers reliable, it does not guarantee the accuracy, adequacy or completeness of any material contained in or referred to in the CRISIL Report, is not responsible for any errors or omissions in or for the results obtained from the use of or decision made based on the CRISIL Report and is not responsible to update the contents of the CRISIL Report for any changes which may take place post the date of issuance of the CRISIL Report. The CRISIL Report highlights certain industry and market data relating to our Company, its competitors and customers. Such data is subject to many assumptions. There are no standard data gathering methodologies in the industry in which we conduct our business, and methodologies and assumptions may vary widely among different industry sources. Further, such assumptions may change based on various factors. We cannot assure you that CRISIL Limited’s assumptions are correct or will not change and, accordingly, our position in the market may differ from that presented in this Draft Red Herring Prospectus. Further, the CRISIL Report is not a

recommendation to invest or disinvest in our Company or any company covered in the CRISIL Report. CRISIL has stated that it is not responsible for any loss or damage arising from the use of the CRISIL Report. You are advised not to unduly rely on the CRISIL Report when making your investment decision.

We have also relied on certain other industry sources, including the F&S Report for industry related data that has been disclosed in this Draft Red Herring Prospectus. These reports use certain methodologies for market sizing and forecasting. We have not independently verified such data and therefore, while we believe them to be true, we cannot assure you that they are complete or reliable.

Accordingly, investors should read the industry-related disclosure in this Draft Red Herring Prospectus in this context. Industry sources and publications are also prepared based on information as of specific dates and may no longer be current or reflect current trends. Industry sources and publications may also base their information on estimates, projections, forecasts and assumptions that may prove to be incorrect. While industry sources take due care and caution while preparing their reports, they do not guarantee the accuracy, adequacy or completeness of the data. Accordingly, investors should not place undue reliance on, or base their investment decision solely on, this information.

For further details, see “*Industry Overview*” beginning on page 87.

## **External Risk Factors**

47. ***The occurrence of natural or man-made disasters could adversely affect our results of operations, cash flows and financial condition. Hostilities, terrorist attacks, civil unrest and other acts of violence could adversely affect the financial markets and our business.***

The occurrence of natural disasters, including cyclones, storms, floods, earthquakes, tsunamis, tornadoes, fires, explosions, pandemic disease and man-made disasters, including acts of terrorism and military actions, could adversely affect our results of operations, cash flows or financial condition. For instance, on October 12, 2014, Cyclone Hudhud caused damage to the building, plant and machinery at our Visakhapatnam facility and our operations were suspended for approximately a week. While we were able to recover an insurance claim aggregating ₹ 29.79 million we suffered a net loss of ₹ 8.69 million on account of damage to our facility.

Terrorist attacks and other acts of violence or war may adversely affect the Indian securities markets. In addition, any deterioration in international relations, especially between India and its neighbouring countries, may result in investor concern regarding regional stability which could adversely affect the price of the Equity Shares. In addition, India has witnessed local civil disturbances in recent years and it is possible that future civil unrest as well as other adverse social, economic or political events in India could have an adverse effect on our business. Such incidents could also create a greater perception that investment in Indian companies involves a higher degree of risk and could have an adverse effect on our business and the market price of the Equity Shares.

48. ***Our business is affected by global economic conditions, especially in the geographies we cater to, which may have an adverse effect on our business, financial condition, results of operations and prospects.***

Our business depends substantially on global economic conditions. The global economic downturn, which began in 2008, coupled with the global financial and credit market disruptions, weakened end markets, diminished demand and credit availability, and increased borrowing costs. A significant majority of the end users of our products are located and operating in North and South America, Europe, Japan and India and some of them were adversely impacted by the economic downturn in these economies, disruption in banking and financial systems, economic weakness, unfavourable government policies, rising inflation, lowering of spending power and customer confidence, and political uncertainty.

There may also be a number of secondary effects of an economic downturn, such as the insolvency of suppliers or customers, delays in deliveries by suppliers, payment delays and/or stagnant/lower demand by customers. Cuts in federal or central, state and local government investment as well as consequent impairment in infrastructural facilities and infrastructural growth can also drag global and national growth rates down. We are thus unable to predict with any degree of certainty the volumes of federal or central, state and local government investment, or the effects of regulatory intervention.

In June 2016, a majority of voters in the United Kingdom elected to withdraw from the European Union in a national referendum. On March 29, 2017, the British Prime Minister delivered a notice to the European Council pursuant to Article 50 of the Treaty of the European Union to initiate the formal process of withdrawal from the European Union. The Article 50 notice dated March 29, 2017, started a two-year period for the United Kingdom to negotiate the terms of its exit from the European Union, although this period can be extended with the unanimous agreement of the European Council. The United Kingdom and the European Union are currently engaged in negotiations to structure their post-Brexit relationship, but significant uncertainty remains about the future relationship between the

United Kingdom and the European Union. Further, starting from early 2018, U.S. President Donald J. Trump announced the imposition of tariffs on goods from certain countries, such as China, entering the United States and recently both China and the U.S. have each imposed additional tariffs. The United States may also in the future impose tariffs on the importation of other products that may affect the global economy. Although we do not currently export any such products to the United States, it is not yet clear what impact these tariffs may have or what actions other governments, including the Chinese government, may take in retaliation. These developments have had and may continue to have a material adverse effect on global economic conditions and the stability of global and Indian financial markets and may significantly reduce global and Indian market liquidity and restrict the ability of key market participants to operate in certain financial markets. For instance, in the second half of 2018, there has been significant volatility in the Indian stock markets due to the financial issues surrounding Infrastructure Leasing & Financial Services Limited as well as liquidity issues amongst financial institutions due to various factors.

If we are unable to successfully anticipate and respond to changing economic and credit market conditions, our business, financial condition, results of operations and prospects may be adversely affected.

49. ***Political, economic or other factors that are beyond our control may have an adverse impact on our business, financial condition, results of operations and prospects.***

We are dependent on domestic, regional and global economic and market conditions. Our performance, growth and market price of our Equity Shares are and will be dependent to a large extent on the health of the economy in which we operate. There have been periods of slowdown in the economic growth of India. Demand for our products may be adversely affected by an economic downturn in domestic, regional and global economies. Economic growth in the countries in which we operate is affected by various factors including domestic consumption and savings, balance of trade movements, namely export demand and movements in key imports (oil and oil products), global economic uncertainty and liquidity crisis, volatility in exchange currency rates, and annual rainfall which affects agricultural production. Consequently, any future slowdown in the Indian economy could harm our business, results of operations, financial condition and cash flows. Also, a change in the government or a change in the economic and deregulation policies, including in respect of tariff and non-tariff barriers, could adversely affect economic conditions prevalent in the areas in which we operate in general and our business in particular and a downgrade of India's sovereign rating by international credit rating agencies, a decline in foreign exchange reserves or high rates of inflation in India could increase our costs without proportionately increasing our revenues, and as such decrease our operating margins.

These factors include the government's policy and priorities regarding different regional economies across India and the general condition and prospects of the overall economy of India. Any significant reduction in the Indian government's budget relating to housing or infrastructure spending could have a material and adverse effect on our business, financial position and results of operations.

50. ***Changing laws, rules and regulations and legal uncertainties, including adverse application of corporate and tax laws, may adversely affect our business, financial condition, results of operations and prospects.***

The regulatory and policy environment in which we operate is evolving and subject to change. Such changes, including the instances mentioned below, may adversely affect our business, results of operations and prospects, to the extent that we are unable to suitably respond to and comply with any such changes in applicable law and policy. For example, the Government of India implemented a comprehensive national goods and services tax regime with effect from July 1, 2017 that combines multiple taxes and levies by the federal and state governments in to a unified tax structure. In addition, the GAAR became effective from April 1, 2017. The tax consequences of the GAAR provisions being applied to an arrangement could result in denial of tax benefit amongst other consequences. In the absence of any precedents on the subject, the application of these provisions is uncertain and may or may not have an adverse tax impact on us. We have not determined the impact of such proposed legislations on our business. In addition, unfavourable changes in or interpretations of existing, or the promulgation of new, laws, rules and regulations including foreign investment laws governing our business, operations and group structure could result in us being deemed to be in contravention of such laws and/or may require us to apply for additional approvals. We may incur increased costs and other burdens relating to compliance with such new requirements, which may also require significant management time and other resources, and any failure to comply may adversely affect our business, results of operations and prospects. Uncertainty in the applicability, interpretation or implementation of any amendment to, or change in, governing law, regulation or policy, including by reason of an absence, or a limited body, of administrative or judicial precedent may be time consuming as well as costly for us to resolve and may impact the viability of our current business or restrict our ability to grow our business in the future.

51. ***Significant differences exist between Ind AS and other accounting principles, such as US GAAP and IFRS, which may be material to investors' assessments of our Company's financial condition. Our failure to successfully adopt IFRS may have an adverse effect on the price of our Equity Shares.***



Our financial statements are prepared and presented in conformity with Ind AS. Ind AS differs in certain significant respects from U.S. GAAP and other accounting principles with which prospective investors may be familiar in other countries. If our financial statements were to be prepared in accordance with such other accounting principles or U.S. GAAP, our results of operations, cash flows and financial position may be substantially different. Prospective investors should review the accounting policies applied in the preparation of our financial statements, and consult their own professional advisers for an understanding of the differences between these accounting principles and those with which they may be more familiar.

52. ***Our ability to invest in overseas subsidiaries and joint ventures may be constrained by Indian and foreign laws, which may adversely affect our growth strategy and business prospects.***

Under Indian foreign investment laws an Indian company is permitted to invest in its overseas joint ventures or subsidiaries up to 400% of its net worth as on the date of its last audited balance sheet. This limit also applies to any other form of financial commitment by the Indian company, including in terms of a loan, guarantee or counter guarantee. However, any financial commitment exceeding US\$ 1 billion (or its equivalent) in a financial year would require prior approval of the Reserve Bank of India, even when the total financial commitment of the Indian company is within the eligible limit as mentioned above.

Other restrictions include the restriction on an Indian company from providing an “open ended” guarantee for an overseas entity (i.e., not specifying the amount and period of the guarantee upfront). Investment or financial commitment not complying with the stipulated requirements is permitted with the RBI’s prior approval. In addition, there are certain routine procedural and disclosure requirements in relation to any such overseas direct investment. These limitations on overseas direct investment may constrain our ability to acquire or increase our stake in overseas entities as well as to provide other forms of financial support to such entities, which may adversely affect our growth strategy and business prospects.

53. ***Our ability to raise capital outside India may be constrained by Indian law, which may adversely affect our financial condition, results of operations and prospects.***

Under India's policy on external commercial borrowing (“**ECB**”), as notified by the RBI and currently in force (“**ECB Policy**”), ECB by an eligible borrower under the manufacturing sector is permitted under the automatic route up to US\$ 750 million in a year, with a minimum average maturity of one year for ECB up to US\$ 50 million for companies in the manufacturing sector, three years for ECB up to US\$ 50 million and five years for ECB beyond US\$ 50 million, for permissible end-uses. End uses for ECB which are not permitted include investment in capital market, equity investment in India, working capital, general corporate purposes, repayment of existing Indian Rupee denominated borrowings, investment in real estate or purchase of land (except when used for affordable housing as defined in the Harmonised Master List of Infrastructure Sub-sectors notified by Government of India, construction and development of SEZ and industrial parks/integrated townships) and on-lending or investment for acquisition of a company or part thereof (other than an overseas subsidiary or joint venture, subject to existing laws and regulations governing overseas direct investment by Indian companies). Further, the ECB Policy limits the all-in-cost with a spread over 450 basis points per annum over the London Interbank Offered Rate for six months or applicable benchmark for the respective currency. ECB not complying with these requirements is permitted with prior approval of the RBI, in accordance with the ECB Policy. In addition, there are certain routine procedural and disclosure requirements in relation to any such ECB.

These limitations on ECB may constrain our ability to raise cost effective funding for implementing asset purchases, refinancing existing indebtedness, or financing acquisitions and other strategic transactions in the future, which may adversely affect our business, financial condition, results of operations and prospects.

54. ***Investors may not be able to enforce a judgment of a foreign court against us.***

Our Company is incorporated under the laws of India. A majority of our Directors and Key Managerial Personnel are residents of India and a significant portion of our operating assets are located in India. As a result, it may not be possible for investors to effect service of process on us or such persons outside India or enforce judgments obtained against such parties outside India.

India has reciprocal recognition and enforcement of judgments in civil and commercial matters with only a limited number of jurisdictions, such as the United Kingdom, Singapore and Hong Kong. In order to be enforceable, a judgment from a jurisdiction with reciprocity must meet certain requirements of the Indian Code of Civil Procedure, 1908 (“**CPC**”). The CPC only permits the enforcement and execution of monetary decrees in the reciprocating jurisdiction, not being in the nature of any amounts payable in respect of taxes, other charges, fines or penalties. Judgments or decrees from jurisdictions which do not have reciprocal recognition with India cannot be enforced by proceedings in execution in India. Therefore, a final judgment for the payment of money rendered by any court in a non-reciprocating territory for civil liability, whether or not predicated solely upon the general laws of the non-reciprocating territory, would not be enforceable in India.

The party in whose favour a final foreign judgment in a non-reciprocating territory is rendered may bring a fresh suit in a competent court in India based on the final judgment within three years of obtaining such final judgment. However, it is unlikely that a court in India would award damages on the same basis as a foreign court if an action were brought in India or that an Indian court would enforce foreign judgments if it viewed the amount of damages as excessive or inconsistent with Indian public policy.

### **Risks Related to our Equity Shares**

55. ***Our Promoters and Promoter Group will retain majority shareholding in our Company following the Offer, which will allow them to exercise significant influence over us and may cause us to take actions that are not in our or your best interest.***

After the completion of this Offer, our Promoters and Promoter Group will collectively hold a significant portion of our Company's issued and outstanding Equity Shares. So long as our Promoters and Promoter Group own a significant portion of our Equity Shares, they will be able to significantly influence the election of our Directors and control most matters affecting our Company, including our business strategies and policies, decisions with respect to mergers, business combinations, acquisitions or dispositions of assets, dividend policies, capital structure and financing, and may also delay or prevent a change of management or control, even if such a transaction may be beneficial to other shareholders of our Company. The interests of our Promoters and Promoter Group, as the controlling shareholders of our Company, may also conflict with our Company's interests or the interests of our Company's other shareholders. As a result, our Promoters and Promoter Group may take actions that conflict with our Company's interests or the interests of other shareholders of our Company.

56. ***There is no guarantee that our Equity Shares will be listed on the Stock Exchanges in a timely manner or at all, which may restrict your ability to dispose of our Equity Shares.***

In accordance with Indian law and practice, permission for listing and trading of our Equity Shares will not be granted until after certain actions have been completed in relation to this Offer and until Allotment of Equity Shares pursuant to this Offer. Trading in our Equity Shares is currently expected to commence within six Working Days from the Bid/Offer Closing Date or such other period as may be specified under applicable law. However, we cannot assure you that the trading in our Equity Shares will commence in a timely manner or at all. Any failure or delay in obtaining final listing and trading approvals may restrict your ability to dispose of your Equity Shares.

57. ***Our Equity Shares have not been publicly traded prior to this Offer. After this Offer, our Equity Shares may experience price and volume fluctuations and an active trading market for our Equity Shares may not develop. Further, the price of our Equity Shares may be volatile, and you may be unable to resell your Equity Shares at or above the Offer Price, or at all.***

Prior to this Offer, there has been no public market for our Equity Shares. An active trading market on the Stock Exchanges may not develop or be sustained after this Offer. Listing and quotation does not guarantee that a market for the Equity Shares will develop or, if developed, that there will be sufficient liquidity for the Equity Shares in such a market. The Offer Price of the Equity Shares is proposed to be determined through a book building process and may not be indicative of the market price of the Equity Shares at the time of commencement of trading of the Equity Shares or at any time thereafter.

The trading price of our Equity Shares after this Offer may be subject to significant fluctuations due to the following factors, some of which are beyond our control:

- quarterly variations in our results of operations;
- results of operations that vary from the expectations of securities analysts and investors;
- results of operations that vary from those of our competitors;
- changes in expectations as to our future financial performance, including financial estimates by research analysts and investors;
- a change in research analysts' recommendations;
- announcements by us or our competitors of significant acquisitions, strategic alliances, joint operations or capital commitments; announcements by third parties or governmental entities of significant claims or proceedings against us;
- new laws and governmental regulations applicable to our industry;

- additions or departures of key management personnel;
- changes in exchange rates;
- fluctuations in stock market prices and volume; and
- general economic and stock market conditions, including stock market volatility caused by the adverse impact of issues related to large listed companies.

Changes in relation to any of the factors listed above could adversely affect the price of the Equity Shares. The market price of the Equity Shares may decline below the Offer Price and investors may not be able to re-sell Equity Shares at or above the Offer Price resulting in a loss of all or part of the investment.

58. ***Fluctuation in the exchange rate between the Indian Rupee and other foreign currencies may have an adverse effect on the value of our Equity Shares, independent of our operating results.***

On listing, our Equity Shares will be quoted in Indian Rupees on the Stock Exchanges. Any dividends in respect of our Equity Shares will also be paid in Indian Rupees and subsequently converted into the relevant foreign currency for repatriation, if required. Any adverse movement in currency exchange rates during the time that it takes to undertake such conversion may reduce the net dividend to foreign investors. In addition, any adverse movement in currency exchange rates during a delay in repatriating outside India the proceeds from a sale of Equity Shares, for example, because of a delay in regulatory approvals that may be required for the sale of Equity Shares may reduce the proceeds received by Equity Shareholders.

For example, the exchange rate between the Indian Rupee and the US\$ has fluctuated substantially in recent years, in particular has significantly declined in the year 2018, and may continue to fluctuate substantially in the future, which may have an adverse effect on the trading price of our Equity Shares and returns on our Equity Shares, independent of our operating results.

59. ***You may be subject to Indian taxes arising out of capital gains on the sale of our Equity Shares.***

Under current Indian tax laws, unless specifically exempted, capital gains arising from the sale of equity shares in an Indian company is generally taxable in India. A securities transaction tax (“STT”) is levied on and collected by an Indian stock exchange on which equity shares are sold. As stipulated by the Finance Act, 2017, where no STT had been paid at the time of acquisition of such equity shares on or before October 1, 2004, the beneficial capital gains provisions under the Income Tax Act would not be available (except in specified cases). Prior to April 1, 2018, all long term capital gains on sale of listed security on stock exchange, subject to payment of STT, were exempt from tax. However, the Finance Act, 2018, has now levied taxes on such long term capital gains arising from sale of equity shares on or after April 1, 2018. However, where specified conditions are met, such long term capital gains are only taxed to the extent they exceed ₹ 100,000 and unrealised capital gains earned up to January 31, 2018 continue to be exempt.

Further, any gain realized on the sale of our Equity Shares held for a period of 12 months or less will be subject to short term capital gains tax in India. Capital gains arising from the sale of the Equity Shares will be exempt from taxation in India in cases where the exemption from taxation in India is provided under a treaty between India and the country of which the seller is a resident. Generally, Indian tax treaties do not limit India’s ability to impose tax on capital gains. As a result, residents of other countries may be liable for tax in India as well as in their own jurisdiction on a gain upon the sale of Equity Shares. Accordingly, you may be subject to payment of long term capital gains tax in India, in addition to the payment of STT, on the sale of Equity Shares held for more than 12 months. STT will be levied on and collected by a domestic stock exchange on which our Equity Shares are sold.

60. ***Our Company’s ability to pay dividends in the future will depend on our future cash flows, working capital requirements, capital expenditures and financial condition.***

Our ability to pay dividends in the future will depend on our earnings, financial condition, cash flow, working capital requirements, capital expenditure and restrictive covenants of our financing arrangements. Any future determination as to the declaration and payment of dividends will be at the discretion of our Board and will depend on factors that our Board deems relevant, including among others, our future earnings, financial condition, cash requirements, business prospects and any other financing arrangements. Additionally, our ability to pay dividends may also be restricted by the terms of financing arrangements that we may enter into. Dividends distributed by us will attract dividend distribution tax at rates applicable from time to time. We cannot assure you that we will be able to pay dividends in the future. For further details, see “Dividend Policy” on page 161.

61. ***QIBs and Non-Institutional Investors are not permitted to withdraw or lower their Bids (in terms of quantity of Equity Shares or the Bid Amount) at any stage after submitting a Bid.***

Pursuant to the SEBI ICDR Regulations, QIBs and Non-Institutional Investors are not permitted to withdraw or lower their Bids (in terms of quantity of Equity Shares or the Bid Amount) at any stage after submitting a Bid. Retail Individual Investors can revise their Bids during the Bid/ Offer Period and withdraw their Bids until Bid/Offer Closing Date. While our Company is required to complete Allotment pursuant to the Offer within six Working Days from the Bid/Offer Closing Date, events affecting the Bidders' decision to invest in the Equity Shares, including material adverse changes in international or national monetary policy, financial, political or economic conditions, our business, results of operation or financial condition may arise between the date of submission of the Bid and Allotment. Our Company may complete the Allotment of the Equity Shares even if such events occur, and such events limit the Bidders' ability to sell the Equity Shares Allotted pursuant to the Offer or cause the trading price of the Equity Shares to decline on listing.

62. ***Government regulation of foreign ownership of Indian securities may have an adverse effect on the price of our Equity Shares.***

Foreign ownership of Indian securities is subject to Government regulation. In accordance with foreign exchange regulations currently in effect in India, under certain circumstances, the RBI must approve the sale of the Equity Shares from a non-resident of India to a resident of India or vice-versa if the sale does not meet certain requirements specified by the RBI. Additionally, any person who seeks to convert the Indian Rupee proceeds from any such sale into foreign currency and repatriate that foreign currency from India is required to obtain a no-objection or a tax clearance certificate from the Indian income tax authorities. As provided in the foreign exchange controls currently in effect in India, the RBI has provided that the price at which the Equity Shares are transferred be calculated in accordance with internationally accepted pricing methodology for the valuation of shares at an arm's length basis, and a higher (or lower, as applicable) price per share may not be permitted. We cannot assure investors that any required approval from the RBI or any other government agency can be obtained on terms favorable to a non-resident investor in a timely manner or at all. Because of possible delays in obtaining requisite approvals, investors in the Equity Shares may be prevented from realizing gains during periods of price increase or limiting losses during periods of price decline.

63. ***Any future issuance of Equity Shares may dilute your shareholding, and sales of Equity Shares by our major shareholders may adversely affect the trading price of our Equity Shares.***

We may be required to finance our growth through future equity offerings. Any future equity issuances by our Company, including a primary offering, may lead to the dilution of investors' shareholdings in the Company. Any future issuances of Equity Shares or the disposal of Equity Shares by our shareholders or the perception that such issuance or sale may occur, may adversely affect the trading price of the Equity Shares, which may lead to other adverse consequences including difficulty in raising capital through offering of the Equity Shares or incurring additional debt. Any future issuances could also dilute the value of your investment in the Equity Shares. In addition, any perception by investors that such issuances or sales might occur may also affect the market price of the Equity Shares.

64. ***Holders of Equity Shares may be restricted in their ability to exercise pre-emptive rights under Indian law and thereby suffer future dilution of their ownership position.***

Under the Companies Act, a company having share capital and incorporated in India must offer its holders of equity shares pre-emptive rights to subscribe and pay for a proportionate number of equity shares to maintain their existing ownership percentages before the issuance of any new equity shares, unless the pre-emptive rights have been waived by adoption of a special resolution by our Company.

However, if the laws of the jurisdiction the investors are located in do not permit them to exercise their pre-emptive rights without our filing an offering document or registration statement with the applicable authority in such jurisdiction, the investors will be unable to exercise their pre-emptive rights unless our Company makes such a filing. If our Company elects not to file a registration statement, the new securities may be issued to a custodian, who may sell the securities for the investor's benefit. The value the custodian receives on the sale of such securities and the related transaction costs cannot be predicted. In addition, to the extent that the investors are unable to exercise pre-emptive rights granted in respect of the Equity Shares held by them, their proportional interest in our Company would be reduced.

65. ***Rights of shareholders under Indian law may be more limited than under the laws of other jurisdictions.***

Indian legal principles related to corporate procedures, directors' fiduciary duties and liabilities, and shareholders' rights may differ from those that would apply to a company in another jurisdiction. Shareholders' rights including in relation to class actions, under Indian law may not be as extensive as shareholders' rights under the laws of other countries or jurisdictions. Investors may have more difficulty in asserting their rights as shareholder in an Indian company than as shareholder of a corporation in another jurisdiction.

## SECTION III: INTRODUCTION

### THE OFFER

Offer <sup>(1)(2)</sup>	[●] Equity Shares, aggregating up to ₹ [●] million
of which	
Fresh Issue <sup>(1)</sup>	[●] Equity Shares, aggregating up to ₹ 1,000 million
Offer for Sale <sup>(2)</sup> comprises:	13,060,770 Equity Shares, aggregating up to ₹ [●] million
A) Investor Selling Shareholders	
(i) Ambadevi	2,154,192 Equity Shares, aggregating up to ₹ [●] million
(ii) Ashoka	7,180,642 Equity Shares, aggregating up to ₹ [●] million
B) Individual Selling Shareholders	
(i) Andrew Warren Code	177,378 Equity Shares, aggregating up to ₹ [●] million
(ii) Bradley Lorenz Miller	16,366 Equity Shares, aggregating up to ₹ [●] million
(iii) Craig A Johnson	5,010 Equity Shares, aggregating up to ₹ [●] million
(iv) Dennis Francis DeDecker	57,420 Equity Shares, aggregating up to ₹ [●] million
(v) Diana Lynn Craig	8,340 Equity Shares, aggregating up to ₹ [●] million
(vi) James Norman Hallene	177,378 Equity Shares, aggregating up to ₹ [●] million
(vii) Kevin John Code	177,378 Equity Shares, aggregating up to ₹ [●] million
(viii) Marc Christopher Dorau	7,710 Equity Shares, aggregating up to ₹ [●] million
(ix) Mark Louis Dawson	20,870 Equity Shares, aggregating up to ₹ [●] million
(x) Mary Louise Arp	10,440 Equity Shares, aggregating up to ₹ [●] million
(xi) Meher Soni	1,444,280 Equity Shares, aggregating up to ₹ [●] million
(xii) Melvin Keith Gibbs	41,730 Equity Shares, aggregating up to ₹ [●] million
(xiii) Misty Marie Garcia	826 Equity Shares, aggregating up to ₹ [●] million
(xiv) Pamela Soni	1,534,548 Equity Shares, aggregating up to ₹ [●] million
(xv) Walter James Gruber	24,706 Equity Shares, aggregating up to ₹ [●] million
(xvi) Wendy Reichard Hammen	21,556 Equity Shares, aggregating up to ₹ [●] million
The Offer comprises:	
A) QIB Portion <sup>(3)(4)</sup>	Up to [●] Equity Shares
of which:	
(i) Anchor Investor Portion	Not more than [●] Equity Shares
of which:	
Available for allocation to Mutual Funds only	[●] Equity Shares
Balance for all QIBs including Mutual Funds	[●] Equity Shares
(ii) Net QIB Portion (assuming Anchor Investor Portion is fully subscribed)	[●] Equity Shares
of which:	
(a) Mutual Fund Portion	[●] Equity Shares
(b) Balance for all QIBs including Mutual Funds	[●] Equity Shares
B) Non-Institutional Portion <sup>(4)</sup>	Not less than [●] Equity Shares
C) Retail Portion <sup>(4)</sup>	Not less than [●] Equity Shares
<b>Pre and post Offer Equity Shares</b>	
Equity Shares outstanding prior to the Offer	45,133,758 Equity Shares
Equity Shares outstanding after the Offer*	[●] Equity Shares
<b>Utilisation of Net Proceeds</b>	See “Objects of the Offer” beginning on page 76 for information about the use of the Net Proceeds. Our Company will not receive any proceeds from the Offer for Sale.

\* To be updated upon finalization of the Offer Price.

- (1) The Offer has been authorized by a resolution of our Board dated November 23, 2018 and the Fresh Issue has been authorized by a special resolution of our Shareholders, dated November 27, 2018.
- (2) The Equity Shares being offered by the Selling Shareholders have been held for a period of at least one year immediately preceding the date of this Draft Red Herring Prospectus with the SEBI, and are eligible for being offered for sale pursuant to the Offer in terms of the SEBI ICDR Regulations. For details of authorizations received for the Offer for Sale, see “Other Regulatory and Statutory Disclosures” beginning on page 261.
- (3) Our Company and the Investor Selling Shareholders may, in consultation with the BRLMs, allocate up to 60% of the QIB Portion to Anchor Investors on a discretionary basis. The QIB Portion will accordingly be reduced for the Equity Shares allocated to Anchor Investors. One-third of the Anchor Investor Portion shall be reserved for domestic Mutual Funds, subject to valid Bids being received from domestic Mutual Funds at or above the Anchor Investor Allocation Price. In the event of under-subscription in the Anchor Investor Portion, the remaining Equity Shares shall be added to the QIB Portion. 5% of the QIB Portion (excluding Anchor Investor Portion) shall be available for allocation on a proportionate basis to Mutual Funds only, and the remainder of the QIB Portion (excluding Anchor Investor Portion) shall be available for allocation on a proportionate basis to all QIB Bidders (other than Anchor Investors), including Mutual Funds, subject to valid Bids being received at or above the Offer Price. In the event the aggregate demand from Mutual Funds is less than as specified above, the balance Equity Shares available for Allotment in the Mutual Fund Portion will be added to the QIB Portion and allocated proportionately to the QIB Bidders (other than Anchor Investors) in proportion to their Bids. For details, see “Offer Procedure” beginning on page 277.
- (4) Subject to valid Bids being received at or above the Offer Price, under-subscription, if any, in any category except the QIB Portion, would be allowed to be met with spill over from any other category or combination of categories at the discretion of our Company, the BRLMs and the Designated Stock Exchange. In the event of under-subscription in the Offer, Equity Shares shall be allocated in the manner specified in the section “Terms of the Offer” beginning on page 271.

Allocation to all categories, except the Anchor Investor Portion and the Retail Portion, if any, shall be made on a proportionate basis, subject to valid Bids received at or above the Offer Price. The allocation to each Retail Individual Bidder shall not be less than the minimum Bid Lot, subject to availability of Equity Shares in Retail Portion, and the remaining available Equity Shares, if any, shall be Allocated on a proportionate basis. For further details, see “*Offer Procedure*” beginning on page 277.

For details of the terms of the Offer, see “*Terms of the Offer*” beginning on page 271.

## SUMMARY OF FINANCIAL INFORMATION

*The summary financial information presented below should be read in conjunction with “Financial Information” and “Management’s Discussion and Analysis of Financial Condition and Results of Operations” beginning on pages 162 and 241, respectively.*

*[The remainder of this page has intentionally been left blank]*

**Restated Consolidated Statement of Assets and Liabilities**  
**(All amounts in millions of INR, unless stated otherwise)**

Particulars	As at September 30, 2018	As at March 31, 2018	As at March 31, 2017 Proforma Ind AS	As at March 31, 2016 Proforma Ind AS
<b>ASSETS</b>				
<b>I. Non-Current assets</b>				
(a) Property, plant and equipment	2,282.48	1,913.72	1,884.69	1,927.48
(b) Capital work-in-progress	124.71	283.95	100.10	20.18
(c) Goodwill	604.90	584.82	597.35	598.33
(d) Other Intangible assets	17.66	17.77	21.16	30.49
(e) Intangible assets under development	24.93	21.60	18.01	4.48
(f) Financial assets				
(i) Loans	6.08	2.27	1.87	2.48
(ii) Other non-current financial assets	51.11	48.46	38.36	38.38
(g) Income Tax Assets (net)	71.61	96.40	82.68	138.00
(h) Other Non-Current Assets	44.50	54.73	27.36	11.49
<b>II. Current assets</b>				
(a) Inventories	3,784.95	3,041.80	2,273.54	2,287.21
(b) Financial assets				
(i) Trade receivables	1,453.67	1,156.99	1,008.25	983.03
(ii) Cash and cash equivalents	102.66	90.44	54.59	49.65
(iii) Bank Balances other than (ii) above	-	1.05	1.77	1.02
(iv) Derivative instruments	(65.72)	1.92	44.90	31.34
(v) Other current financial assets	0.61	0.63	0.52	0.62
(c) Other current assets	402.51	420.81	305.79	369.28
<b>Total assets</b>	<b>8,906.66</b>	<b>7,737.36</b>	<b>6,460.94</b>	<b>6,493.46</b>
<b>EQUITY AND LIABILITIES</b>				
(a) Equity share capital	446.20	446.20	446.20	446.20
(b) Other equity	3,438.31	3,198.90	2,732.33	2,495.78
<b>Total equity</b>	<b>3,884.51</b>	<b>3,645.10</b>	<b>3,178.53</b>	<b>2,941.98</b>
<b>Liabilities</b>				
<b>I. Non-current liabilities</b>				
(a) Financial liabilities				
(i) Borrowings	220.70	242.98	178.67	298.19
(b) Provisions	145.05	112.97	83.31	61.64
(c) Deferred tax liabilities (net)	259.36	248.50	288.46	269.38
(d) Other non-current liabilities	17.53	22.75	29.74	40.55
<b>II. Current liabilities</b>				
(a) Financial liabilities				
(i) Borrowings	2,791.63	2,103.56	1,629.10	1,872.09
(ii) Trade payables				
- Total outstanding dues to micro enterprises and small enterprises	6.25	-	-	-
- Total outstanding dues other than to micro enterprises and small enterprises	1,052.31	875.48	605.10	578.46
(iii) Other current financial liabilities (other than (c))	118.90	124.71	140.09	133.65
(b) Other current liabilities	338.87	292.33	265.34	206.29
(c) Provisions	50.98	55.33	51.37	45.61
(d) Current Tax Liabilities (net)	20.57	13.65	11.23	45.62
<b>Total liabilities</b>	<b>5,022.15</b>	<b>4,092.26</b>	<b>3,282.41</b>	<b>3,551.48</b>
<b>Total equity and liabilities</b>	<b>8,906.66</b>	<b>7,737.36</b>	<b>6,460.94</b>	<b>6,493.46</b>



**Restated Consolidated Statement of Profit and Loss**  
(All amounts in millions of INR, unless stated otherwise)

Particulars	For the Period ended September 30, 2018	For the Year ended March 31, 2018	For the Year ended March 31, 2017 Proforma Ind AS	For the Year ended March 31, 2016 Proforma Ind AS
<b>Income</b>				
Revenue from operations	5,157.11	8,461.86	7,031.47	7,795.20
Other income	3.89	9.30	20.72	20.23
<b>Total income (i)</b>	<b>5,161.00</b>	<b>8,471.16</b>	<b>7,052.19</b>	<b>7,815.43</b>
<b>Expenses</b>				
Cost of raw materials and components consumed	2,176.41	3,369.36	2,389.33	2,813.98
Purchase of Stock-in- trade	-	-	1.37	3.03
Changes in Inventories	(616.83)	(548.01)	27.06	(52.59)
Excise duty on sale of goods	-	44.04	106.47	106.35
Employee benefits expense	1,053.55	1,769.58	1,581.81	1,595.76
Finance costs	70.22	90.32	86.55	100.48
Depreciation and amortisation expense	111.06	208.53	197.66	184.89
Other expenses	1,764.63	2,831.10	2,266.87	2,446.03
<b>Total expenses (ii)</b>	<b>4,559.04</b>	<b>7,764.92</b>	<b>6,657.12</b>	<b>7,197.93</b>
Profit before exceptional items and tax (i - ii)	<b>601.96</b>	<b>706.24</b>	<b>395.07</b>	<b>617.50</b>
Exceptional items gain/(loss)/prior period items	-	-	-	-
<b>Profit before tax</b>	<b>601.96</b>	<b>706.24</b>	<b>395.07</b>	<b>617.50</b>
Tax expense				
-For Current year	121.05	195.15	100.09	137.13
MAT credit	13.40	13.63	20.64	33.55
Deferred tax (Credit)/Charge	25.77	(37.88)	9.14	(0.29)
<b>Total tax expense</b>	<b>160.22</b>	<b>170.90</b>	<b>129.87</b>	<b>170.39</b>
<b>Profit for the period / year</b>	<b>441.74</b>	<b>535.33</b>	<b>265.20</b>	<b>447.12</b>
<b>Other comprehensive income</b>				
a) Other Comprehensive Income that will be reclassified to profit or loss in subsequent period				
- Net movement on cash flow hedges	(65.72)	1.92	44.90	31.34
- Exchange differences in translating the financial statements of foreign operations	(93.14)	(64.14)	1.80	(80.92)
- Income tax effect	(22.25)	0.67	15.38	10.69
	<b>(136.61)</b>	<b>(62.89)</b>	<b>31.32</b>	<b>(60.27)</b>
b) Other Comprehensive Income that will not to be reclassified to profit or loss in subsequent period				
- Re-measurement gains / (losses) of defined benefit plans	(17.13)	(9.07)	(10.31)	(5.82)
- Income tax effect	(5.80)	(2.90)	(2.08)	(0.56)
	<b>(11.33)</b>	<b>(6.17)</b>	<b>(8.23)</b>	<b>(5.26)</b>
<b>Other comprehensive income for the period / year (a+b)</b>	<b>(147.94)</b>	<b>(69.06)</b>	<b>23.08</b>	<b>(65.53)</b>
<b>Total comprehensive income for the period / year</b>	<b>293.80</b>	<b>466.27</b>	<b>288.28</b>	<b>381.59</b>
<b>Profit is attributable to:</b>				
Owners of the Company	441.74	535.33	265.20	447.12
Non-controlling interest	-	-	-	-
	<b>441.74</b>	<b>535.33</b>	<b>265.20</b>	<b>447.12</b>
<b>Other comprehensive income is attributable to:</b>				
Owners of the Company	(147.94)	(69.06)	23.08	(65.53)
Non-controlling interest	-	-	-	-
	<b>(147.94)</b>	<b>(69.06)</b>	<b>23.08</b>	<b>(65.53)</b>
<b>Total comprehensive income is attributable to:</b>				
Owners of the Company	293.80	466.27	288.28	381.59
Non-controlling interest	-	-	-	-
	<b>293.80</b>	<b>466.27</b>	<b>288.28</b>	<b>381.59</b>
<b>Earnings per Equity Share</b>				
Basic (Amount in INR)	10.02	12.14	6.01	10.14
Diluted (Amount in INR)	9.79	11.86	5.88	9.91

**Restated Consolidated Statement of Cash Flow**  
**(All amounts in millions of INR, unless stated otherwise)**

Particulars	For the Period ended September 30, 2018	For the Year ended March 31, 2018	For the Year ended March 31, 2017 Proforma Ind AS	For the Year ended March 31, 2016 Proforma Ind AS
<b>A: CASH FLOW FROM OPERATING ACTIVITIES:</b>				
<b>Profit before tax</b>	<b>601.96</b>	<b>706.24</b>	<b>395.07</b>	<b>617.50</b>
<b>Adjustments to reconcile profit before tax to net cash flows</b>				
- Depreciation and amortization on continuing operation:	111.06	208.53	197.66	184.89
- Share issue expenses written off	-	-	(52.51)	-
- Deferred Tax	13.14	0.15	(3.36)	8.32
- Employee Benefits Expense	0.02	0.29	0.77	1.49
- Loss/(profit) on sale of fixed assets	0.56	(2.09)	4.06	1.00
- Interest Expenses	59.08	72.60	71.80	85.89
- Profit on sale of Investments	-	-	(0.13)	-
- Effects of Consolidation	(134.91)	(55.16)	8.48	(97.16)
- Interest Income	(1.75)	(1.88)	(4.58)	(8.44)
<b>Operating profit before working capital changes</b>	<b>649.16</b>	<b>928.67</b>	<b>617.26</b>	<b>793.49</b>
<b>Movement in working capital :</b>				
Increase/(decrease) in trade payable	183.08	270.38	26.64	(32.87)
Increase/(decrease) in current provisions	(4.35)	3.96	5.76	3.66
Increase/(decrease) in non-current provisions	14.95	20.59	11.36	5.81
Increase/(decrease) in other current liabilities other than Deferred Government Gran	(5.07)	(11.28)	(10.82)	(5.83)
Increase/(decrease) in Deferred Government Grant	(0.15)	4.29	-	-
Increase/(decrease) in other current liabilities	79.18	(12.31)	54.88	4.75
Increase/(decrease) in current tax liabilities	6.93	2.43	(34.39)	44.58
Increase/(decrease) in other current financial liabilities:	(5.82)	(15.38)	6.44	(5.30)
Decrease/(increase) in trade receivables	(296.68)	(148.74)	(25.24)	(64.75)
Decrease/(increase) in derivative instruments	1.92	44.90	31.34	17.15
Decrease/(increase) in inventories	(743.15)	(768.26)	13.67	(53.43)
Decrease/(increase) in other current assets	18.30	(115.02)	63.50	(94.41)
Decrease/(increase) in other current financial assets	0.02	(0.12)	0.11	0.03
Decrease/(increase) in other non-current assets	10.23	(27.37)	(15.87)	7.62
Decrease/(increase) in Income Tax Assets	24.79	(13.72)	55.32	46.00
Decrease/(increase) in non-current loans	(3.81)	(0.40)	0.61	1.65
Decrease/(increase) in other non-current financial assets	(2.65)	(10.10)	0.02	(6.49)
<b>Cash generated from/(used in) operations</b>	<b>(73.12)</b>	<b>152.52</b>	<b>800.59</b>	<b>661.66</b>
Direct taxes paid (net of refunds)	(134.45)	(208.78)	(120.73)	(184.08)
<b>Net cash flow from/ (used in) operating activities</b>	<b>(207.57)</b>	<b>(56.26)</b>	<b>679.86</b>	<b>477.58</b>
<b>B: CASH FLOW FROM INVESTING ACTIVITIES</b>				
(Purchase)/ sale of property, plant and Equipment; including intangible assets,				
CWIP and capital advances	(305.86)	(426.30)	(252.22)	(406.95)
Proceeds from sale of property, plant & equipment	4.09	7.82	4.83	4.39
Interest income	1.75	1.89	4.58	8.44
Profit on sale of investments	-	-	0.13	-
<b>Net cash flow from/ (used in) investing activities</b>	<b>(300.02)</b>	<b>(416.59)</b>	<b>(242.68)</b>	<b>(394.13)</b>
<b>C: CASH FLOW FROM FINANCING ACTIVITIES</b>				
Proceeds/(Repayment) of long-term borrowings	(22.28)	64.30	(119.51)	(17.16)
Current borrowings repayments (net)	688.07	474.46	(242.99)	167.79
Dividends Paid (including dividend distribution tax)	(54.41)	-	-	(40.93)
Interest paid	(59.08)	(72.60)	(71.80)	(85.89)
<b>Net cash flow from/ (used in) financing activities</b>	<b>552.30</b>	<b>466.16</b>	<b>(434.30)</b>	<b>23.81</b>
<b>Net Increase/(Decrease) in Cash and Cash Equivalents</b>	<b>44.71</b>	<b>(6.69)</b>	<b>2.88</b>	<b>107.26</b>
Cash and cash equivalent balance at the beginning of the year	91.49	56.36	50.67	36.09
Net Increase/(Decrease) in Temporary Overdraft	(32.64)	39.29	4.17	(94.64)
Effects of exchange difference on cash and cash equivalent held in foreign currency	(0.90)	2.53	(1.36)	1.95
<b>Cash and cash equivalent balance at the end of the period/year [refer note 10]</b>	<b>102.66</b>	<b>91.49</b>	<b>56.36</b>	<b>50.67</b>

**Restated Consolidated Statement of Cash Flow**  
 (All amounts in millions of INR, unless stated otherwise)

**Cash and Cash equivalents for the purpose of cash flow statement**

Particulars	For the Period ended September 30, 2018	For the Year ended March 31, 2018	For the Year ended March 31, 2017 Proforma Ind AS	For the Year ended March 31, 2016 Proforma Ind AS
<b>Balances with banks:</b>				
In cash credit and current accounts	96.42	87.25	52.37	47.09
In EEFC accounts	3.08	0.00	0.00	0.43
In other bank balances	-	1.05	1.77	1.02
Cash on hand	3.16	3.19	2.22	2.13
<b>Total</b>	<b>102.66</b>	<b>91.49</b>	<b>56.36</b>	<b>50.67</b>

## GENERAL INFORMATION

Our Company was incorporated as “Uniparts India Limited” under the Companies Act, 1956 at Delhi, pursuant to a certificate of incorporation dated September 26, 1994 issued by the RoC. Our Company received a certificate of commencement of business on September 7, 1998 from the RoC.

### Registered Office

#### Uniparts India Limited

Gripwel House  
Block – 5  
Sector C 6 & 7  
Vasant Kunj  
New Delhi 110 070  
India

### Corporate Office

#### Uniparts India Limited

Ground Floor, SB Tower  
Plot 1A/1, Sector 16 A  
Film City  
Noida 201 301  
India  
Registration Number: 061753

### Address of the RoC

Our Company is registered with the RoC situated at:

#### National Capital Territory of Delhi and Haryana

4<sup>th</sup> Floor, IFCI Tower  
61, Nehru Place  
New Delhi 110 019  
India

### Board of Directors

The Board of our Company comprises of the following:

Name	Designation	DIN	Address
Gurdeep Soni	Chairman and Managing Director	00011478	Silveroak Estates, 142, Mall Road, Kishan Garh, Vasant Kunj, New Delhi, 110 070, India
Paramjit Singh Soni	Executive Director	00011616	596, High Hampton, Dr. Martinez, GA 30907-9183, USA
Herbert Coenen	Executive Director	00916001	Vinxeler Street, 74A, Koenigswinter, 53639, Germany
Ashish Kumar Agarwal*	Nominee Director	00139386	B 402, Vivarea Tower, Sane Guruji Marg, Near Mahalaxmi Station, Jacob circle, Mumbai 400 011, India
Alok Nagory	Independent Director	00478140	7/197, Swaroop Nagar, Kanpur 208 002, India
M.R. Umarji	Independent Director	00307435	B-702, Pataliputra CHS, 4 Bungalows, Near Kamdhenu Department Store, Andheri (West), Mumbai 400 053, India
Sharat Krishan Mathur	Independent Director	01217742	E-323/2, Greater Kailash – I, New Delhi 110 048, India
Shradha Suri	Independent Director	00176902	N-101, Panchsheel Park, New Delhi 110 017, India

\* Upon listing and commencement of trading of the Equity Shares and simultaneous termination of the SHA, Ashish Kumar Agarwal will resign from our Board.

For further details in relation to our Directors, see “Our Management” beginning on page 143.

### Company Secretary and Compliance Officer

Mukesh Kumar is the Company Secretary, Compliance Officer and Associate Vice President - Legal of our Company. His contact details are as follows:

#### Mukesh Kumar

Ground Floor, SB Tower  
Plot 1A/1, Sector 16 A  
Film City

Noida 201 301  
India  
Tel: + 91 120 458 1400  
E-mail: compliance.officer@unipartsgroup.com

### Statutory Auditors to our Company

#### **Rakesh Banwari & Co., Chartered Accountants**

10/52, 2<sup>nd</sup> Floor, Subhash Nagar  
New Delhi 110 027  
India  
Tel: +91 11 4502 4859  
E-mail: rbandco@hotmail.com  
Firm Registration No.: 009732N  
Peer Review Number: 011320

### Changes in the auditors

Except as disclosed below, there has been no change in the statutory auditors during the three years immediately preceding the date of this Draft Red Herring Prospectus:

<b>Name of the Auditors</b>	<b>Date of change</b>	<b>Reason for change</b>
<b>S.C. Varma and Co., Chartered Accountants</b> A-60, NDSE, Part I, New Delhi 110 049 India E-mail: scvarma@scvandco.com Firm Registration No.: 000533N Peer Review Number: 005944	September 22, 2017	Completion of term of appointment
<b>Rakesh Banwari &amp; Co., Chartered Accountants</b> 10/52, 2 <sup>nd</sup> Floor, Subhash Nagar, New Delhi 110 027 India E-mail: rbandco@hotmail.com Firm Registration No.: 009732N Peer Review Number: 011320	September 22, 2017	Appointment as Statutory Auditors

### Book Running Lead Managers

#### **Axis Capital Limited**

Axis House, Level 1  
C-2 Wadia International Centre,  
P. B. Marg, Worli, Mumbai 400 025  
India  
Tel: +91 22 4325 2183  
E-mail: uil.ipo@axiscap.in  
Investor grievance e-mail: complaints@axiscap.in  
Website: www.axiscapital.co.in  
Contact Person: Bhumika Gangar  
SEBI Registration No.: INM000012029

#### **Motilal Oswal Investment Advisors Limited**

Motilal Oswal Tower  
Rahimtullah Sayani Road  
Opposite Parel ST Depot, Prabhadevi  
Mumbai 400 025  
India  
Tel: +91 22 3846 4200  
E-mail: uniparts.ipo@motilaloswal.com  
Investor grievance e-mail: moiapredressal@motilaloswal.com  
Website: www.motilaloswalgroup.com  
Contact Person: Keyur Desai/ Kristina Dias  
SEBI Registration No.: INM000011005

#### **SBI Capital Markets Limited**

202, Market Tower 'E'  
Cuffe Parade,  
Mumbai 400 005  
India  
Tel: +91 22 2217 8300  
E-mail: uniparts.ipo@sbicaps.com  
Investor grievance e-mail: investor.relations@sbicaps.com  
Website: www.sbicaps.com  
Contact Person: Karan Savardekar/ Janardhan Wagle  
SEBI Registration No.: INM000003531

### Syndicate Members

[●]

**Indian Legal Counsel to our Company**

**Cyril Amarchand Mangaldas**

4<sup>th</sup> floor, Prius Platinum  
D-3, District Centre  
Saket, New Delhi 110 017  
India  
Tel: +91 11 6622 9000

**Indian Legal Counsel to the Book Running Lead Managers**

**Shardul Amarchand Mangaldas & Co**

Amarchand Towers  
216, Okhla Industrial Estate  
Phase III, New Delhi 110 020  
India  
Tel: +91 11 4159 0700

**Indian Legal Counsel to the Investor Selling Shareholders**

**Khaitan & Co**

One Indiabulls Centre  
13<sup>th</sup> Floor, Tower 1  
841 Senapati Bapat Marg  
Mumbai 400 013  
India  
Tel: +91 22 6636 5000

**Registrar to the Offer**

**Link Intime Private Limited**

C-101, 1<sup>st</sup> Floor, 247 Park,  
L.B.S Marg, Vikhroli (West)  
Mumbai 400 083  
India  
Tel: +91 22 4918 6200  
E-mail: uniparts.ipo@linkintime.co.in  
Investor grievance e-mail: uniparts.ipo@linkintime.co.in  
Website: www.linkintime.co.in  
Contact Person: Shanti Gopalkrishnan  
SEBI Registration No.: INR000004058

**Bankers to the Offer**

[●]

**Bankers to our Company**

**Citibank N.A.**

1<sup>st</sup> Floor, DLF Capitol Point  
Baba Kharak Singh Marg, Connaught Place  
New Delhi 110 001  
India  
Tel: +91 124 418 6912  
E-mail: shrey.agarwal@citi.com  
Website: www.online.citibank.co.in  
Contact person: Shrey Agarwal

**DBS Bank Limited**

Capitol Point, Baba Kharak Singh Marg  
Connaught Place  
New Delhi 110 001  
India  
Tel: +91 011 6653 8800  
E-mail: vikramg@dbs.com  
Website: www.dbsbank.com  
Contact person: Vikram Gupta

**RBL Bank Limited**

One Indiabulls Centre  
Tower 2B, 6<sup>th</sup> Floor  
841 Senapati Bapat Marg

**Kotak Mahindra Bank Limited**

Kotak Aerocity, 1<sup>st</sup> Floor, Asset Area 9  
IBIS Commercial Block, Delhi Aerocity  
New Delhi 110 037

Lower Parel (W)  
Mumbai 400 013  
India  
Tel: +91 022 4302 0609  
E-mail: secretarial@rblbank.com  
Website: www.rblbank.com  
Contact person: Vinay Tripathi

India  
Tel: +91 011 6617 6143  
E-mail: ashish.sabharwal@kotak.com  
Website: www.kotak.com  
Contact person: Ashish Sabharwal

### **IndusInd Bank Limited**

3<sup>rd</sup> Floor, Tower B, Building No. 10  
Cybercity, Phase 2  
Gurgaon 122 002  
India  
Tel: +91 0124 474 9500  
E-mail: divya.mehta@indusind.com  
Website: www.indusind.com  
Contact person: Divya Mehta

### **Designated Intermediaries**

#### **Self Certified Syndicate Banks**

The list of banks that have been notified by SEBI to act as the SCSBs for the ASBA process is provided on the website of SEBI at [www.sebi.gov.in/sebiweb/other/OtherAction.do?doRecognised=yes](http://www.sebi.gov.in/sebiweb/other/OtherAction.do?doRecognised=yes) or at such other website as may be prescribed by SEBI from time to time. For a list of branches of SCSBs named by the respective SCSBs to receive ASBA Forms from the Designated Intermediaries and updated from time to time, refer to the above-mentioned link or any such other website as may be prescribed by SEBI from time to time.

#### **Syndicate SCSB Branches**

In relation to Bids (other than Bids by Anchor Investors) submitted under the ASBA process to a member of the Syndicate, the list of branches of the SCSBs at the Specified Locations named by the respective SCSBs to receive deposits of Bid cum Application Forms from the members of the Syndicate is available on the website of the SEBI at [www.sebi.gov.in/sebiweb/other/OtherAction.do?doRecognised=yes](http://www.sebi.gov.in/sebiweb/other/OtherAction.do?doRecognised=yes) and updated from time to time or any such other website as may be prescribed by SEBI from time to time. For more information on such branches collecting Bid cum Application Forms from the Syndicate at Specified Locations, see the website of the SEBI at [www.sebi.gov.in/sebiweb/other/OtherAction.do?doRecognised=yes](http://www.sebi.gov.in/sebiweb/other/OtherAction.do?doRecognised=yes) or any such other website as may be prescribed by SEBI from time to time.

#### **Registered Brokers**

The list of the Registered Brokers eligible to accept ASBA forms, including details such as postal address, telephone number and e-mail address, is provided on the websites of the BSE and the NSE at [www.bseindia.com/Markets/PublicIssues/brokercentres\\_new.aspx](http://www.bseindia.com/Markets/PublicIssues/brokercentres_new.aspx) and [www.nseindia.com/products/content/equities/ipos/ipo\\_mem\\_terminal.htm](http://www.nseindia.com/products/content/equities/ipos/ipo_mem_terminal.htm), respectively, as updated from time to time.

#### **Registrar and Share Transfer Agents**

The list of the RTAs eligible to accept ASBA Forms at the Designated RTA Locations, including details such as address, telephone number and e-mail address, is provided on the websites of Stock Exchanges at [www.bseindia.com/Static/Markets/PublicIssues/RtaDp.aspx](http://www.bseindia.com/Static/Markets/PublicIssues/RtaDp.aspx) and [www.nseindia.com/products/content/equities/ipos/asba\\_procedures.htm](http://www.nseindia.com/products/content/equities/ipos/asba_procedures.htm), respectively, as updated from time to time.

#### **Collecting Depository Participants**

The list of the CDPs eligible to accept ASBA Forms at the Designated CDP Locations, including details such as name and contact details, is provided on the websites of BSE at [www.bseindia.com/Static/Markets/PublicIssues/RtaDp.aspx](http://www.bseindia.com/Static/Markets/PublicIssues/RtaDp.aspx) and on the website of NSE at [www.nseindia.com/products/content/equities/ipos/asba\\_procedures.htm](http://www.nseindia.com/products/content/equities/ipos/asba_procedures.htm), as updated from time to time.

#### **Monitoring Agency**

Our Company shall appoint a monitoring agency in relation to the Fresh Issue, if required under Regulation 41 the SEBI ICDR Regulations prior to filing of the Red Herring Prospectus.

## Appraising Entity

None of the objects for which the Net Proceeds will be utilised have been appraised by any agency.

## Inter-se Allocation of Responsibilities

The following table sets forth the inter-se allocation of responsibilities for various activities among the BRLMs for the Offer.

S. No	Activity	Responsibility	Co-ordination
1.	<ul style="list-style-type: none"> <li>Capital structuring with the relative components and formalities such as composition of debt and equity, type of instruments, and positioning strategy</li> <li>Pre-Issue due diligence of the Company including its operations/management/business plans/legal etc., drafting and design of DRHP, RHP and Prospectus, ensure compliance and completion of prescribed formalities with the Stock Exchanges, SEBI and RoC including finalisation of RHP, Prospectus and RoC filing</li> </ul>	Axis, Motilal Oswal, SBICAP	Axis
2.	Drafting and approval of all advertisements, publicity material, including corporate advertising, brochures, etc.	Axis, Motilal Oswal, SBICAP	Axis
3.	Appointment of Registrar to the Offer, Advertising agency (including coordinating all agreements to be entered with such parties)	Axis, Motilal Oswal, SBICAP	SBICAP
4.	Appointment of Printers, Banker(s) to the Offer (including coordinating all agreements to be entered with such parties)	Axis, Motilal Oswal, SBICAP	Motilal Oswal
5.	Preparation of roadshow presentation and FAQs for the roadshow team	Axis, Motilal Oswal, SBICAP	Axis
6.	International institutional marketing of the Offer, which will cover, inter alia: <ul style="list-style-type: none"> <li>Finalizing the list and division of international investors for one-to-one meetings</li> <li>Finalizing international road show and investor meeting schedules</li> </ul>	Axis, Motilal Oswal, SBICAP	Axis
7.	Domestic institutional marketing of the Offer, which will cover, inter alia: <ul style="list-style-type: none"> <li>Finalizing the list and division of domestic investors for one-to-one meetings</li> <li>Finalizing domestic road show and investor meeting schedules</li> </ul>	Axis, Motilal Oswal, SBICAP	Motilal Oswal
8.	Non-Institutional and Retail marketing of the Offer, which will cover, inter alia: <ul style="list-style-type: none"> <li>Formulating marketing strategies, preparation of publicity budget</li> <li>Finalise media and PR strategy</li> <li>Finalising centres for holding conferences for press and brokers</li> <li>Finalising collection centres;</li> <li>Follow-up on distribution of publicity and Issuer material including form, prospectus and deciding on the quantum of the Offer material</li> </ul>	Axis, Motilal Oswal, SBICAP	SBICAP
9.	Co-ordination with Stock Exchanges for book building software, bidding terminals, mock trading and for deposit of 1% security deposit and intimation of anchor allocation	Axis, Motilal Oswal, SBICAP	SBICAP
10.	Finalization of pricing in consultation with the Company	Axis, Motilal Oswal, SBICAP	Axis
11.	Post-issue activities, which shall involve essential follow-up steps including follow-up with bankers to the issue and Self Certified Syndicate Banks to get quick estimates of collection and advising the issuer about the closure of the issue, based on correct figures, finalisation of the basis of allotment or weeding out of multiple applications, listing of instruments, dispatch of certificates or demat credit and refunds and coordination with various agencies connected with the post-issue activity such as registrars to the issue, bankers to the issue, Self-Certified Syndicate Banks etc. Including responsibility for underwriting arrangements, as applicable, coordinating with Stock Exchanges and SEBI for release of 1% security deposit post closure of the Issue and payment of STT on behalf of the Selling Shareholders	Axis, Motilal Oswal, SBICAP	Motilal Oswal

## Credit Rating

As this is an offer of Equity Shares, there is no credit rating for the Offer.



## **IPO Grading**

No credit rating agency registered with SEBI has been appointed for grading the Offer.

## **Trustees**

As this is an offer of Equity Shares, the appointment of trustees is not required.

## **Filing of this Draft Red Herring Prospectus**

This Draft Red Herring Prospectus has been filed with the Securities and Exchange Board of India at:

### **Securities and Exchange Board of India**

Corporation Finance Department  
Division of Issues and Listing  
SEBI Bhavan, Plot No. C4 A, 'G' Block  
Bandra Kurla Complex  
Bandra (East)  
Mumbai 400 051, India

The Red Herring Prospectus and Prospectus will be filed along with the material contracts and documents referred to in the Red Herring Prospectus at:

## **Registrar of Companies**

### **National Capital Territory of Delhi and Haryana**

4<sup>th</sup> Floor, IFCI Tower  
61, Nehru Place  
New Delhi 110 019  
India

## **Book Building Process**

The book building process, in the context of the Offer, refers to the process of collection of Bids from investors on the basis of the Red Herring Prospectus and the Bid cum Application Form within the Price Band, which will be decided by our Company and the Investor Selling Shareholders in consultation with the BRLMs, and advertised in [●] editions of [●] (a widely circulated English national daily newspaper) and [●] editions of [●] (a widely circulated Hindi national daily newspaper, Hindi also being the regional language of New Delhi where our Registered Office is located), at least two Working Days prior to the Bid/Offer Opening Date and shall be made available to the Stock Exchanges for the purpose of uploading on their respective websites. The Offer Price shall be determined by our Company and the Investor Selling Shareholders in consultation with the BRLMs after the Bid/ Offer Closing Date.

**All Bidders, except Anchor Investors, can participate in the Offer only through the ASBA process.**

**In accordance with the SEBI ICDR Regulations, QIBs and Non-Institutional Bidders are not permitted to withdraw or lower the size of their Bids (in terms of the quantity of the Equity Shares or the Bid Amount) at any stage. Retail Individual Bidders can revise their Bids during the Bid/ Offer Period and withdraw their Bids until the Bid/ Offer Closing Date. Further, Anchor Investors cannot withdraw their Bids after the Anchor Investor Bid/ Offer Period. Allocation to QIBs in the QIB Portion (other than the Anchor Investor Portion) will be on a proportionate basis and allocation to Anchor Investors will be on a discretionary basis.** For further details, see "*Terms of the Offer*" and "*Offer Procedure*" beginning on pages 271 and 277, respectively.

**The process of Book Building under the SEBI ICDR Regulations and the Bidding Process are subject to change from time to time and the investors are advised to make their own judgment about investment through this process prior to submitting a Bid in the Offer.**

Bidders should note that the Offer is also subject to obtaining (i) final approval of the RoC after the Prospectus is filed with the RoC; and (ii) final listing and trading approvals from the Stock Exchanges, which our Company shall apply for after Allotment.

For further details on the method and procedure for Bidding, see "*Offer Procedure*" beginning on page 277.

## Underwriting Agreement

After the determination of the Offer Price, but prior to the filing of the Prospectus with the RoC, our Company and the Selling Shareholders will enter into an Underwriting Agreement with the Underwriters for the Equity Shares proposed to be offered through the Offer. Subject to the applicable laws and pursuant to the terms of the Underwriting Agreement, the BRLMs will be responsible for bringing in the amount devolved in the event that the Syndicate Members do not fulfil their underwriting obligations. The Underwriting Agreement is dated [●]. Pursuant to the terms of the Underwriting Agreement, the obligations of the Underwriters will be several and will be subject to certain conditions specified therein.

The Underwriters have indicated their intention to underwrite the following number of Equity Shares:

*(This portion has been intentionally left blank and will be completed before filing the Prospectus with the RoC.)*

Name, address, telephone number and e-mail address of the Underwriters	Indicative Number of Equity Shares to be Underwritten	Amount Underwritten (₹ in millions)
[●]	[●]	[●]

The above-mentioned is indicative underwriting and will be finalised after determination of Offer Price and Basis of Allotment and subject to the provisions of the SEBI ICDR Regulations.

In the opinion of the Board, the resources of the Underwriters are sufficient to enable them to discharge their respective underwriting obligations in full. The Underwriters are registered with SEBI under Section 12(1) of the SEBI Act or registered as brokers with the Stock Exchange(s). The Board/ IPO Committee, at its meeting held on [●], has accepted and entered into the Underwriting Agreement mentioned above on behalf of our Company.

Allocation among the Underwriters may not necessarily be in proportion to their underwriting commitment.

## CAPITAL STRUCTURE

The Equity Share capital of our Company as on the date of this Draft Red Herring Prospectus is set forth below:

*(In ₹ except share data)*

		Aggregate value at face value	Aggregate value at Offer Price
<b>A</b>	<b>AUTHORIZED SHARE CAPITAL</b>		
	60,000,000 Equity Shares of face value of ₹10 each	600,000,000	-
<b>B</b>	<b>ISSUED, SUBSCRIBED AND PAID-UP CAPITAL BEFORE THE OFFER</b>		
	45,133,758 Equity Shares of face value ₹ 10 each	451,337,580	-
<b>C</b>	<b>PRESENT OFFER IN TERMS OF THIS DRAFT RED HERRING PROSPECTUS</b>		
	Offer of [●] Equity Shares <sup>(1)(2)</sup>	[●]	[●]
	<i>of which</i>		
	Fresh Issue of [●] Equity Shares <sup>(1)</sup>	[●]	1,000,000,000
	Offer for Sale of 13,060,770 Equity Shares <sup>(2)</sup>	130,607,700	[●]
<b>E</b>	<b>ISSUED, SUBSCRIBED AND PAID-UP CAPITAL AFTER THE OFFER</b>		
	[●] Equity Shares of face value of ₹ 10 each*	[●]	[●]
<b>D</b>	<b>SECURITIES PREMIUM ACCOUNT</b>		
	Before the Offer		789,301,437
	After the Offer		[●]

\* To be updated upon finalization of the Offer Price.

- (1) The Offer has been authorized by a resolution of our Board dated November 23, 2018 and the Fresh Issue has been authorized by a special resolution of our Shareholders, dated November 27, 2018.
- (2) The Equity Shares being offered by the Selling Shareholders have been held for a period of at least one year immediately preceding the date of this Draft Red Herring Prospectus with the SEBI, and are eligible for being offered for sale pursuant to the Offer in terms of the SEBI ICDR Regulations. For details of authorizations received for the Offer for Sale, see "Other Regulatory and Statutory Disclosures" beginning on page 261.

### Notes to the Capital Structure

#### 1. Equity Share Capital History of our Company

The history of the Equity Share capital of our Company is set forth in the table below.

Date of Allotment	Name(s) of allottee(s)	Nature of Allotment	No. of Equity Shares Allotted	Face Value (₹)	Issue price per Equity Share (₹)	Form of consideration
October 3, 1994	10 Equity Shares each to Kirpal Singh, Gurdeep Soni, Paramjit Singh Soni, Harjit K. Singh, Pamela Soni, Sarabjit Soni and Joginder S. Chatha	Initial subscription to the Memorandum of Association	70	10	10.00	Cash
December 14, 1998	90 Equity Shares to Paramjit Singh Soni	Preferential allotment	90	10	10.00	Cash
March 28, 2000	1,990 Equity Shares to Harjit K. Singh, 19,590 Equity Shares to Kirpal Singh, 19,590 Equity Shares to Gurdeep Soni, 19,590 Equity Shares to Sarabjit Soni, 19,500 Equity Shares to Paramjit Singh Soni and 19,490 Equity Shares to Pamela Soni	Preferential allotment	99,750	10	10.00	Cash
March 31, 2005	3,217,500 Equity Shares to Gurdeep Soni, 3,217,500 Equity Shares to Paramjit Singh Soni, 466,090 Equity Shares to Pamela Soni, 466,000 Equity Shares to Sarabjit Soni, 385,100 Equity Shares to Kirpal Singh and 240,800 Equity Shares to Harjit K. Singh	Preferential allotment	7,992,990	10	10.00	Cash

Date of Allotment	Name(s) of allottee(s)	Nature of Allotment	No. of Equity Shares Allotted	Face Value (₹)	Issue price per Equity Share (₹)	Form of consideration
February 2, 2007	1,294,840 Equity Shares to Gurdeep Soni, 1,294,840 Equity Shares to Paramjit Singh Soni, 194,240 Equity Shares to Sarabjit Soni, 194,236 Equity Shares to Pamela Soni, 161,880 Equity Shares to Kirpal Singh, 97,120 Equity Shares to Harjit K. Singh, and 4 Equity Shares to Angad Soni	Bonus issue in the ratio of two Equity Shares for every five existing Equity Shares	3,237,160	10	-	N.A.
February 2, 2007	Uniparts ESOP Trust	Preferential allotment	350,400	10	135.00	Cash
June 12, 2007	59,126 Equity Shares to Andrew Warren Code, 59,126 Equity Shares to James Norman Hallene, 59,126 Equity Shares to Kevin John Code, 19,140 Equity Shares to Dennis Francis DeDecker, 13,910 Equity Shares to Melvin Keith Gibbs, 10,435 Equity Shares to Mark Louis Dawson, 8,235 Equity Shares to Walter James Gruber, 7,185 Equity Shares to Wendy Reichard Hammen, 5,455 Equity Shares to Bradley Lorenz Miller, 3,480 Equity Shares to Mary Louise Arp, 2,780 Equity Shares to Diana Lynn Craig, 2,570 Equity Shares to Marc Christopher Dorau, 1,670 Equity Shares to Craig A. Johnson and 275 Equity Shares to Misty Marie Garcia	Preferential allotment	252,513	10	294.71	Cash
September 25, 2007	1,957,331 Equity Shares to Ashoka and 587,199 Equity Shares to Ambadevi	Preferential allotment	2,544,530	10	294.75	Cash
March 27, 2009	436,216 Equity Shares to Ashoka and 130,865 Equity Shares to Ambadevi	Preferential allotment	567,081	10	10.00	Cash
August 4, 2009	2,492,595 Equity Shares to Gurdeep Soni, 2,492,595 Equity Shares to Paramjit Singh Soni, 1,196,774 Equity Shares to Ashoka, 359,032 Equity Shares to Ambadevi, 339,920 Equity Shares to Sarabjit Soni, 309,934 Equity Shares to Pamela Soni, 175,200 Equity Shares to Uniparts ESOP Trust, 29,563 Equity Shares to Andrew Warren Code, 29,563 Equity Shares to James Norman Hallene, 29,563 Equity Shares to Kevin John Code, 24,986 Equity Shares to Angad Soni, 9,570 Equity Shares to Dennis Francis DeDecker, 6,955 Equity Shares to Melvin Keith Gibbs, 5,218 Equity Shares to Rini Kalra, 5,000 Equity Shares to Arjun Soni, 4,118 Equity Shares to Walter James Gruber, 3,593 Equity Shares to Wendy Reichard Hammen, 2,728 Equity Shares to Bradley Lorenz Miller, 1,740 Equity Shares to Mary Louise Arp, 1,390 Equity Shares to Diana Lynn Craig, 1,285 Equity Shares to Marc Christopher Dorau, 835 Equity Shares to Craig A. Johnson and 138	Rights issue of one Equity Share for every two existing Equity Shares held as on the record date being July 4, 2009	7,522,295	10	45.00	Cash

Date of Allotment	Name(s) of allottee(s)	Nature of Allotment	No. of Equity Shares Allotted	Face Value (₹)	Issue price per Equity Share (₹)	Form of consideration
	Equity Shares to Misty Marie Garcia					
April 4, 2014	7,477,785 Equity Shares to Gurdeep Soni, 3,590,321 Equity Shares to Ashoka, 3,297,545 Equity Shares to Paramjit Singh Soni, 2,600,000 Equity Shares to Meher Soni, 2,600,000 Equity Shares to Karan Soni, 1,077,096 Equity Shares to Ambadevi, 989,760 Equity Shares to Pamela Soni, 525,600 Equity Shares to Uniparts ESOP Trust, 25,000 Equity Shares to Angad Soni, 88,689 Equity Shares to Andrew Warren Code, 88,689 Equity Shares to James Norman Hallene, 88,689 Equity Shares to Kevin John Code, 28,710 Equity Shares to Dennis Francis DeDecker, 20,865 Equity Shares to Melvin Keith Gibbs, 12,353 Equity Shares to Walter James Gruber, 10,778 Equity Shares to Wendy Reichard Hammen, 10,435 Equity Shares to Mark Louis Dawson, 8,183 Equity Shares to Bradley Lorenz Miller, 5,220 Equity Shares to Mary Louise Arp, 5,218 Equity Shares to Rini Kalra, 5,000 Equity Shares to Arjun Soni, 4,170 Equity Shares to Diana Lynn Craig, 3,855 Equity Shares to Marc Christopher Dorau, 2,505 Equity Shares to Craig A. Johnson and 413 Equity Shares to Misty Marie Garcia	Bonus issue in the ratio of one Equity Shares for each Equity Share held by the existing Shareholders	22,566,879	10	-	N.A.

2. Our Company has not issued any Equity Shares or preference shares for consideration other than cash or out of revaluation of reserves at any time since incorporation.
3. Our Company has not issued or allotted any Equity Shares pursuant to any scheme of arrangement approved under Sections 391-394 of the Companies Act, 1956 or Sections 230-234 of the Companies Act, 2013.
4. Our Company has not issued any Equity Shares during a period of one year preceding the date of this Draft Red Herring Prospectus.

5. **Shareholding Pattern of our Company**

The table below presents the shareholding pattern of our Company as on the date of this Draft Red Herring Prospectus.

Category (I)	Category of Shareholder (II)	No. of Shareholders (III)	No. of fully paid up Equity Shares held (IV)	No. of Partly paid-up Equity Shares held (V)	No. of shares underlying depository receipts (VI)	Total No. of shares held (VII) = (IV)+(V)+(VI)	Shareholding as a % of total no. of Equity Shares (calculated as per SCRR) (VIII) As a % of (A+B+C2)	Number of Voting Rights held in each class of securities (IX)			No. of Equity Shares underlying outstanding convertible securities (including warrants) (X)	Shareholding, as a % assuming full conversion of convertible securities (as a percentage of diluted Equity Share capital) (XI)= (VII)+(X) As a % of (A+B+C2)	No. of locked in Equity Shares (XII)		Number of Equity Shares pledged or otherwise encumbered (XIII)		No. of Equity Shares held in dematerialized form (XIV)
								No of Voting Rights					No. (a)	As a % of total shares held (b)	No. (a)	As a % of total shares held (b)	
								Class (Equity)	Total	Total as a % of (A+B+C)							
(A)	Promoter & Promoter Group	7	33,990,180	-	-	33,990,180	75.31	33,990,180	33,990,180	75.31	-	75.31	-	-	-	33,990,180	
(B)	Public	18	10,116,378	-	-	10,116,378	22.41	10,116,378	10,116,378	22.41	-	22.41	-	-	-	9,358,834	
(C)	Non Promoter-Non Public	1	1,027,200	-	-	1,027,200	2.28	1,027,200	1,027,200	2.28	-	2.28	-	-	-	1,027,200	
(C1)	Shares underlying depository receipts	-	-	-	-	-	-	-	-	-	-	-	-	-	-	-	
(C2)	Shares held by employee trusts	1	1,027,200	-	-	1,027,200	2.28	1,027,200	1,027,200	2.28	-	2.28	-	-	-	1,027,200	
	<b>Total (A+B+C)</b>	<b>26</b>	<b>45,133,758</b>	<b>-</b>	<b>-</b>	<b>45,133,758</b>	<b>100.00</b>	<b>45,133,758</b>	<b>45,133,758</b>	<b>100.00</b>	<b>-</b>	<b>100.00</b>	<b>-</b>	<b>-</b>	<b>-</b>	<b>44,376,214</b>	

6. *Other details of Shareholding of our Company*

- (a) As on the date of the filing of this Draft Red Herring Prospectus, our Company has 26 Shareholders.
- (b) Set forth below is a list of Shareholders holding 1% or more of the paid-up Share Capital of our Company, on a fully diluted basis, as on the date of this Draft Red Herring Prospectus.

S. No.	Name of the Shareholder	No. of Equity Shares	Percentage of the pre-Offer Equity Share Capital (%)	Number of Equity Shares on a fully diluted basis	Percentage of the pre-Offer Equity Share Capital on a fully diluted basis
1.	Gurdeep Soni	14,955,570	33.14	14,955,570	33.14
2.	Ashoka	7,180,642	15.91	7,180,642	15.91
3.	Paramjit Singh Soni	6,595,090	14.61	6,595,090	14.61
4.	Karan Soni	5,200,000	11.52	5,200,000	11.52
5.	Meher Soni	5,200,000	11.52	5,200,000	11.52
6.	Ambadevi	2,154,192	4.77	2,154,192	4.77
7.	Pamela Soni	1,979,520	4.39	1,979,520	4.39
8.	Uniparts ESOP Trust	1,027,200	2.28	1,027,200	2.28
	<b>Total</b>	<b>44,292,214</b>	<b>98.14</b>	<b>44,292,214</b>	<b>98.14</b>

- (c) Set forth below is a list of Shareholders holding 1% or more of the paid-up Share Capital of our Company, on a fully diluted basis, as of 10 days prior to the date of this Draft Red Herring Prospectus.

S. No.	Name of the Shareholder	No. of Equity Shares	Percentage of the pre-Offer Equity Share Capital (%)	Number of Equity Shares on a fully diluted basis	Percentage of the pre-Offer Equity Share Capital on a fully diluted basis
1.	Gurdeep Soni	14,955,570	33.14	14,955,570	33.14
2.	Ashoka	7,180,642	15.91	7,180,642	15.91
3.	Paramjit Singh Soni	6,595,090	14.61	6,595,090	14.61
4.	Karan Soni	5,200,000	11.52	5,200,000	11.52
5.	Meher Soni	5,200,000	11.52	5,200,000	11.52
6.	Ambadevi	2,154,192	4.77	2,154,192	4.77
7.	Pamela Soni	1,979,520	4.39	1,979,520	4.39
8.	Uniparts ESOP Trust	1,027,200	2.28	1,027,200	2.28
	<b>Total</b>	<b>44,292,214</b>	<b>98.14</b>	<b>44,292,214</b>	<b>98.14</b>

- (d) Set forth below is a list of Shareholders holding 1% or more of the paid-up Share Capital of our Company, on a fully diluted basis, as of one year prior to the date of this Draft Red Herring Prospectus.

S. No.	Name of the Shareholder	No. of Equity Shares	Percentage of the pre-Offer Equity Share Capital (%)	Number of Equity Shares on a fully diluted basis	Percentage of the pre-Offer Equity Share Capital on a fully diluted basis
1.	Gurdeep Soni	14,955,570	33.14	14,955,570	33.14
2.	Ashoka	7,180,642	15.91	7,180,642	15.91
3.	Paramjit Singh Soni	6,595,090	14.61	6,595,090	14.61
4.	Karan Soni	5,200,000	11.52	5,200,000	11.52
5.	Meher Soni	5,200,000	11.52	5,200,000	11.52
6.	Ambadevi	2,154,192	4.77	2,154,192	4.77
7.	Pamela Soni	1,979,520	4.39	1,979,520	4.39
8.	Uniparts ESOP Trust	1,027,200	2.28	1,027,200	2.28
	<b>Total</b>	<b>44,292,214</b>	<b>98.14</b>	<b>44,292,214</b>	<b>98.14</b>

- (e) Set forth below is a list of Shareholders holding 1% or more of the paid-up Share Capital of our Company, on a fully diluted basis, as of two years prior to the date of this Draft Red Herring Prospectus.

S. No.	Name of the Shareholder	No. of Equity Shares	Percentage of the pre-Offer Equity Share Capital (%)	Number of Equity Shares on a fully diluted basis	Percentage of the pre-Offer Equity Share Capital on a fully diluted basis
1.	Gurdeep Soni	14,955,570	33.14	14,955,570	33.14
2.	Ashoka	7,180,642	15.91	7,180,642	15.91
3.	Paramjit Singh Soni	6,595,090	14.61	6,595,090	14.61
4.	Karan Soni	5,200,000	11.52	5,200,000	11.52
5.	Meher Soni	5,200,000	11.52	5,200,000	11.52

S. No.	Name of the Shareholder	No. of Equity Shares	Percentage of the pre-Offer Equity Share Capital (%)	Number of Equity Shares on a fully diluted basis	Percentage of the pre-Offer Equity Share Capital on a fully diluted basis
6.	Ambadevi	2,154,192	4.77	2,154,192	4.77
7.	Pamela Soni	1,979,520	4.39	1,979,520	4.39
8.	Uniparts ESOP Trust	1,027,200	2.28	1,027,200	2.28
	<b>Total</b>	<b>44,292,214</b>	<b>98.14</b>	<b>44,292,214</b>	<b>98.14</b>

7. Except any grants that may be made under the ESOP 2007, our Company presently does not intend or propose to alter its capital structure for a period of six months from the Bid/Offer Opening Date, by way of split or consolidation of the denomination of Equity Shares, or by way of further issue of Equity Shares (including issue of securities convertible into or exchangeable, directly or indirectly for Equity Shares), whether on a preferential basis, or by way of issue of bonus shares, or on a rights basis, or by way of further public issue of Equity Shares, or otherwise. However, if our Company enters into acquisitions, joint ventures or other arrangements, our Company may, subject to necessary approvals, consider raising additional capital to fund such activity or use Equity Shares as currency for acquisitions or participation in such joint ventures.

8. **Details of Shareholding of our Promoters and members of the Promoter Group in the Company**

- As on the date of this Draft Red Herring Prospectus, our Promoters hold 21,550,660 Equity Shares, equivalent to 47.75% of the issued, subscribed and paid-up Equity Share capital of our Company, as set forth in the table below.

S. No.	Name of the Shareholder	Pre-Offer		Post-Offer*	
		No. of Equity Shares	% of total Shareholding	No. of Equity Shares	% of total Shareholding
1.	Gurdeep Soni	14,955,570	33.14	●	●
2.	Paramjit Singh Soni	6,595,090	14.61	●	●
	<b>Total</b>	<b>21,550,660</b>	<b>47.75</b>	●	●

\* Subject to finalisation of Basis of Allotment.

- Build-up of the Promoters' shareholding in our Company**

The build-up of the Equity Shareholding of our Promoters since incorporation of our Company is set forth in the table below.

Name of Promoter	Nature of transaction	Date of Allotment/ Transfer / Transmission	No. of Equity Shares	Face value per Equity Share (₹)	Issue Price/ Transfer Price per Equity Share (₹)
Gurdeep Soni	Initial subscription to the Memorandum of Association	October 3, 1994	10	10	10
	Preferential allotment	March 28, 2000	19,590	10	10
	Preferential allotment	March 31, 2005	3,217,500	10	10
	Bonus issue in the ratio of two Equity Shares for every five Equity Shares held by the existing Shareholders	February 2, 2007	1,294,840	10	-
	Transmission of Equity Shares from Late Harjit K. Singh	March 27, 2008	169,960	10	10
	Transfer of Equity Shares at par from Kirpal Singh	December 26, 2008	283,290	10	10
	Rights issue in the ratio of one Equity share for every two Equity Shares	August 4, 2009	2,492,595	10	45
	Bonus issue in the ratio of one Equity Shares for each Equity Share	April 4, 2014	7,477,785	10	-
<b>Total</b>					<b>14,955,570</b>
Paramjit Singh Soni	Initial subscription to the Memorandum of Association	October 3, 1994	10	10	10
	Preferential allotment	December 14, 1998	90	10	10
	Preferential allotment	March 28, 2000	19,500	10	10
	Preferential allotment	March 31, 2005	3,217,500	10	10



Name of Promoter	Nature of transaction	Date of Allotment/ Transfer / Transmission	No. of Equity Shares	Face value per Equity Share (₹)	Issue Price/ Transfer Price per Equity Share (₹)
	Bonus issue in the ratio of two Equity Shares for every five Equity Shares held by the existing Shareholders	February 2, 2007	1,294,840	10	-
	Transmission of Equity Shares from Late Harjit K. Singh to Paramjit Singh Soni	March 27, 2008	169,960	10	N.A.
	Transfer of Equity Shares from Kirpal Singh to Paramjit Singh Soni	December 26, 2008	283,290	10	10
	Rights issue	August 4, 2009	2,492,595	10	45
	Gift of 1,580,240 Equity Shares from Paramjit Singh Soni to Meher Soni and gift of 2,600,000 Equity Shares from Paramjit Singh Soni to Karan Soni	December 24, 2012	(4,180,240)	10	N.A.
	Bonus issue in the ratio of one Equity Shares for each Equity Share held by the existing Shareholders	April 4, 2014	3,297,545	10	-
<b>Total</b>					<b>6,595,090</b>

All the Equity Shares held by our Promoters were fully paid-up on the respective dates of allotment or acquisition, as the case may be, of such Equity Shares. Further, none of the Equity Shares held by our Promoters are pledged.

- The details of the Shareholding of the members of the Promoter Group as on the date of this Draft Red Herring Prospectus are set forth in the table below.

S. N.	Name of the Shareholder	Pre-Offer		Post-Offer*	
		No. of Equity Shares	% of total Shareholding	No. of Equity Shares	% of total Shareholding
1.	Pamela Soni	1,979,520	4.39	[●]	[●]
2.	Karan Soni	5,200,000	11.52	[●]	[●]
3.	Meher Soni	5,200,000	11.52	[●]	[●]
4.	Angad Soni	50,000	0.11	[●]	[●]
5.	Arjun Soni	10,000	0.02	[●]	[●]
	<b>Total</b>	<b>12,439,520</b>	<b>27.56</b>	<b>[●]</b>	<b>[●]</b>

\* Subject to finalisation of Basis of Allotment.

- None of the members of the Promoter Group, the Promoters, or the Directors and their relatives have purchased or sold any securities of our Company during the period of six months immediately preceding the date of this Draft Red Herring Prospectus.
- There have been no financing arrangements whereby our Promoters, members of the Promoter Group, our Directors and their relatives have financed the purchase by any other person of securities of our Company during a period of six months immediately preceding the date of this Draft Red Herring Prospectus.

#### 9. Details of Promoters' contribution and lock-in

- Pursuant to Regulations 14 and 16 of the SEBI ICDR Regulations, an aggregate of 20% of the fully diluted post-Offer Equity Share capital of our Company held by the Promoters shall be locked in for a period of three years as minimum promoters' contribution from the date of Allotment ("Promoters' Contribution"), and the Promoters' shareholding in excess of 20% of the fully diluted post-Offer Equity Share capital shall be locked in for a period of one year from the date of Allotment.
- Details of the Equity Shares to be locked-in for three years from the date of Allotment as Promoters' Contribution are set forth in the table below.

Name of the Promoter	Date of allotment of the Equity Shares**	Nature of transaction	No. of Equity Shares**	Face Value (₹)	Issue/ acquisition price per Equity Share (₹)	No. of Equity Shares locked-in*	Percentage of the post-Offer paid-up capital (%)	Date up to which the Equity Shares are subject to lock-in
Gurdeep Soni	[●]	[●]	[●]	[●]	[●]	[●]	[●]	[●]
Paramjit Singh Soni	[●]	[●]	[●]	[●]	[●]	[●]	[●]	[●]
	<b>Total</b>					[●]	[●]	

\* Subject to finalisation of Basis of Allotment.

\*\* All the Equity Shares were fully paid-up on the respective dates of allotment or acquisition, as the case may be, of such Equity Shares.

- (a) Our Promoters have given consent to include such number of Equity Shares held by them as may constitute 20% of the fully diluted post-Offer Equity Share capital of our Company as Promoters' Contribution. Our Promoters have agreed not to sell, transfer, charge, pledge or otherwise encumber in any manner, the Promoters' Contribution from the date of filing of this Draft Red Herring Prospectus, until the expiry of the lock-in period specified above, or for such other time as required under SEBI ICDR Regulations, except as may be permitted, in accordance with the SEBI ICDR Regulations.
- (b) Our Company undertakes that the Equity Shares that are being locked-in are not ineligible for computation of Promoters' Contribution in terms of Regulation 15 of the SEBI ICDR Regulations. In this connection, we confirm the following:
- (i) The Equity Shares offered for Promoters' Contribution do not include (a) Equity Shares acquired in the three years immediately preceding the date of this Draft Red Herring Prospectus for consideration other than cash, and revaluation of assets or capitalisation of intangible assets; or (b) bonus shares out of revaluation reserves or unrealised profits of our Company or bonus shares issued against Equity Shares, which are otherwise ineligible for computation of Promoter's Contribution;
  - (ii) The Promoters' Contribution does not include any Equity Shares acquired during the immediately preceding one year at a price lower than the price at which the Equity Shares are being offered to the public in the Offer;
  - (iii) Our Company has not been formed by the conversion of a partnership firm or a limited liability partnership firm into a company and hence, no Equity Shares have been issued in the one year immediately preceding the date of this Draft Red Herring Prospectus pursuant to conversion from a partnership firm; and
  - (iv) The Equity Shares forming part of the Promoter's Contribution are not subject to any pledge.

#### 10. **Details of other lock-in**

In addition to the 20% of the fully diluted post-Offer shareholding of our Company held by the Promoters and locked in for three years as specified above, the entire pre-Offer Equity Share capital of our Company will be locked-in for a period of one year from the date of Allotment, including any unsubscribed portion of the Offer for Sale, other than (a) the Equity Shares held by the Uniparts ESOP Trust; (b) the Equity Shares which may be transferred to the employees by the Uniparts ESOP Trust pursuant to exercise of options held by such employees (whether currently employees or not), in accordance with the terms of ESOP 2007; and (c) the Equity Shares, if any, held by Ambadevi and Ashoka, each of which is an FVCI, provided that any lock-in provisions under the SEBI FVCI Regulations are complied with.

11. Our Company, the Selling Shareholders, the Promoters, the Directors and the BRLMs have no existing buyback arrangements or any other similar arrangements for the purchase of Equity Shares being offered through the Offer.
12. All Equity Shares issued pursuant to the Offer shall be fully paid-up at the time of Allotment and there are no partly paid-up Equity Shares as on the date of this Draft Red Herring Prospectus.
13. As on the date of this Draft Red Herring Prospectus, the BRLMs and their respective associates (as defined under the Securities and Exchange Board of India (Merchant Bankers) Regulations, 1992) do not hold any Equity Shares of our Company. The BRLMs and their affiliates may engage in the transactions with and perform services for our

Company in the ordinary course of business or may in the future engage in commercial banking and investment banking transactions with our Company for which they may in the future receive customary compensation.

#### 14. *Employee Stock Option Plan*

Our Company instituted an employee stock option plan, namely, the Uniparts Employee Stock Option Plan 2007 (“**ESOP 2007**”), pursuant to a resolution of the Board dated January 8, 2007 and resolution of the Shareholders dated February 2, 2007, which has been amended by the Board on April 4, 2014 and September 26, 2015, respectively, and special resolution of the Shareholders dated February 3, 2018. Our Company has established an employee stock option trust (“**Uniparts ESOP Trust**”) to administer ESOP 2007 of our Company. The objective of ESOP 2007 is to retain and attract key talent, replace current performance bonus with long term incentive, and to create wealth opportunities for employees. The ESOP 2007, as amended by the resolution of the Board and Shareholders passed at their meetings held on November 23, 2018 and November 27, 2018, respectively is in compliance with the Securities and Exchange Board of India (Share Based Employee Benefits) Regulations, 2014.

The following table sets forth the particulars of the options granted under ESOP 2007 as of the date of this Draft Red Herring Prospectus:

Particulars	Details				
	Fiscal 2016	Fiscal 2017	Fiscal 2018	Six Months ended September 30, 2018	As on November 30, 2018
<b>Total options outstanding as at the beginning of the period</b>	684,376	684,376	643,988	643,988	936,488
<b>Increase in number of options granted on account of bonus</b>	NIL	NIL	NIL	NIL	NIL
<b>Total options granted</b>	52,948	NIL	NIL	NIL	1,096,042
<b>Vesting period</b>	Grant 1 to Grant 10 and Grant 12 <ul style="list-style-type: none"> <li>• 33% of the options granted to the grantee shall vest on the expiry of 24 months from the Grant Date</li> <li>• 33% of the options granted to the grantee shall vest on the expiry of 36 months from the Grant Date</li> <li>• 34% of the options granted to the grantee shall vest on the expiry of 48 months from the Grant Date</li> </ul> Grant 11 <ul style="list-style-type: none"> <li>• 100% of the options granted to the grantee shall vest on the expiry of 12 months from the Grant Date</li> </ul>				
<b>Pricing formula</b>	Black Scholes Option Valuation Model has been used for determining the fair value of an option granted under ESOP Scheme.				
<b>Exercise price of options in ₹ (as on the date of grant of options)</b>	52.50	N.A.	N.A.	N.A.	52.50
<b>Options forfeited/ lapsed/ cancelled</b>	147,554				
<b>Variation of terms of options</b>	Vesting period reduced to 12 months	NIL	Exercise period changed from 10 to 15 years	NIL	NIL
<b>Money realised by exercise of options</b>	1,260,000				
<b>Total number of options outstanding in force</b>	936,488				
<b>Total options vested (excluding the options that have been exercised)</b>	643,988				
<b>Options exercised (since implementation of ESOP scheme)</b>	12,000				

Particulars	Details							
	Fiscal 2016	Fiscal 2017	Fiscal 2018	Six Months ended September 30, 2018	As on November 30, 2018			
The total number of Equity Shares arising as a result of exercise of granted options (including options that have been exercised)	936,488							
Employee wise details of options granted to:								
(i) Directors/ key management personnel	Name of Employee		Options					
			Granted	Exercised	Outstanding			
	Herbert Coenen		451,336	-	451,336			
	Rini Kalra		270,826	-	270,826			
	Sudhakar Kolli		100,000	-	100,000			
	Mukesh Kumar		5,000	-	5,000			
(ii) Any other employee who receives a grant in any one year of options amounting to 5% or more of the options granted during the year	Name of Employee	Fiscal 2016	Fiscal 2017	Fiscal 2018	Six Months ended September 30, 2018	October 1, 2018 to November 30, 2018	Percentage of total options granted from October 1, 2018 to November 30, 2018	
	Jyotbir Singh Sethi	-	-	-	-	35,000	11.97%	
	Sameer Malhotra	-	-	-	-	15,000	5.13%	
	Biru Gupta	-	-	-	-	20,000	6.84%	
	Fiscal 2016	Fiscal 2017	Fiscal 2018	Six Months ended September 30, 2018	October 1, 2018 to November 30, 2018			
(iii) Identified employees who were granted options during any one year equal to or exceeding 1% of the issued capital (excluding outstanding warrants and conversions) of the Company at the time of grant	NIL	NIL	NIL	NIL	NIL	NIL		
Lock-in	No lock-in period							
Fully diluted earnings per share pursuant to issue of equity shares on a pre-offer basis on exercise of options in accordance with IND AS 33 'Earning Per Share'	The reported diluted earnings per equity share calculated in accordance with relevant accounting standards is as follows:							
	Particulars	March 31, 2016	March 31, 2017	March 31, 2018	Six months ended September 30, 2018	October 1, 2018 to November 30, 2018		
	Reported Diluted EPS as per Standalone Restated Financial Statements#	5.92	2.97	3.35	2.18	NA		
	Reported Diluted EPS as per Restated Consolidated	9.91	5.88	11.86	9.79	NA		

Particulars	Details					
	Fiscal 2016	Fiscal 2017	Fiscal 2018	Six Months ended September 30, 2018	As on November 30, 2018	
Financial Statements <sup>#</sup>						
	<i><sup>#</sup>The options being anti-dilutive, are ignored in the calculation of diluted EPS.</i>					
Where the Company has calculated the employee compensation cost using the intrinsic value of stock options, difference, if any, between employee compensation cost calculated according using the intrinsic value of stock options and the employee compensation cost calculated on the basis of fair value of stock options and impact of this difference on the profits of the Company and on the earnings per share of the Company	Not applicable since the Company has used fair value of options for the purposes of recognizing the employees compensation cost.					
Weighted average exercise price and the weighted average fair value of options whose exercise price either equals or exceeds or is less than the market price of the stock	Not applicable as market price of the stock is not available for the Company as it is an unlisted company.					
Method and significant assumptions used to estimate the fair value of options granted during the year including weighted average information, namely, risk-free interest rate, expected life, expected volatility, expected dividends, and the price of the underlying share in market at the time of grant of the option	Particulars	March 31, 2016	March 31, 2017	March 31, 2018	Six months ended September 30, 2018	October 1, 2018 to November 30, 2018
	Weighted average share price	49.98	N.A.	N.A.	N.A.	84.91
	Exercise Price	52.50	N.A.	N.A.	N.A.	52.50
	Volatility	14.90%	N.A.	N.A.	N.A.	14.83%
	Life of the options granted in years	15	N.A.	N.A.	N.A.	15
	Average risk-free interest rate	8.12%	N.A.	N.A.	N.A.	7.92%
Intention of key managerial personnel and whole-time directors who are holders of Equity Shares allotted on exercise of options to sell their shares within three months after the listing of Equity Shares pursuant to the Offer	Employees holding Equity Shares issued upon exercise of options granted under the ESOP 2007, may sell such Equity Shares within a period of three months from the date of listing of the Equity Shares.					
Intention to sell Equity Shares arising out of the ESOP Scheme within three months after the listing of Equity Shares by directors, senior management personnel and employees having Equity Shares arising out of the ESOP Scheme, amounting to more than 1% of the issued capital (excluding outstanding warrants and conversions)	Employees holding Equity Shares issued upon exercise of options granted under the ESOP 2007, may sell such Equity Shares within a period of three months from the date of listing of the Equity Shares.					

Particulars	Details				
	Fiscal 2016	Fiscal 2017	Fiscal 2018	Six Months ended September 30, 2018	As on November 30, 2018
<b>Impact on the profits and on the Earnings Per Share of the last three years if the accounting policies prescribed in the Securities and Exchange Board of India (Share Based Employee Benefits) Regulations, 2014 had been followed, in respect of options granted in the last three years.</b>	Employee stock options granted is accounted under the “Fair Value” as per Ind AS 102 ‘share based payments’, notified under Section 133 of the Companies Act 2013 read with the Companies (Indian Accounting Standards) Rules, 2015 as amended. The same is in accordance with the SEBI ESOP Regulations.				
	<b>Fiscal</b>		<b>Effect on Profits</b>		<b>Effect on EPS</b>
	March 31, 2016		1.49		0.03
	March 31, 2017		0.77		0.02
March 31, 2018		0.29		0.00	

## OBJECTS OF THE OFFER

The Offer comprises a Fresh Issue by our Company and an Offer for Sale by the Selling Shareholders.

### The Offer for Sale

The Selling Shareholders will be entitled to the proceeds of the Offer for Sale of their respective portion of the Equity Shares. Our Company will not receive any proceeds from the Offer for Sale.

### The Fresh Issue

Our Company intends to utilize the Net Proceeds from the Fresh Issue towards the following objects:

1. Prepayment/repayment of all or a portion of the outstanding loan facilities availed by our Company; and
2. General corporate purposes.

(Collectively referred to as the “Objects”).

The main objects and objects incidental and ancillary to the main objects set out in our Memorandum of Association enables our Company to undertake its existing business activities and the activities for which funds are being raised by us through the Fresh Issue and for which the loans proposed to be repaid from the Net Proceeds were utilised. In addition, we expect to achieve the benefit of listing of our Equity Shares on the Stock Exchanges.

The details of the Net Proceeds are set forth in the following table:

(In ₹ million)

Particulars	Estimated Amount (In ₹ million)*
Gross proceeds of the Fresh Issue	1,000.00
Less: Offer related expenses to be borne by our Company**	[●]
<b>Net Proceeds</b>	<b>[●]</b>

\* To be determined on finalisation of the Offer Price and updated in the Prospectus prior to the filing with the Registrar of Companies.

\*\* Expenses for the Offer shall be shared amongst our Company and Selling Shareholders as specified in “- Offer Expenses” on page 79.

### Requirements of Funds

The Net Proceeds are proposed to be used in accordance with the details provided in the following table:

Particulars	Amount (In ₹ million)
Prepayment/ repayment of all or a portion of the outstanding loan facilities availed by our Company	750.00
General corporate purposes*	[●]

\* The amount utilised for general corporate purposes shall not exceed 25% of the Gross Proceeds of the Fresh Issue.

### Funding Plan (Means of Finance)

The entire requirement of funds towards the objects of the Offer will be met from the Net Proceeds. Accordingly, as required under the SEBI ICDR Regulations, we confirm that there is no requirement for us to make firm arrangements of finance through verifiable means towards at least 75% of the stated means of finance, excluding the amount to be raised from the Net Proceeds.

### Schedule for Implementation and Deployment of the Net Proceeds

We propose to deploy the Net proceeds in accordance with the estimated schedule as set forth in the table below:

(In ₹ million)

S. No.	Particulars	Amount proposed to be funded from Net Proceeds*	Estimated Utilisation of Net Proceeds in Fiscal 2020
1.	Prepayment/ repayment of all or a portion of the outstanding loan facilities availed by our Company	750.00	750.00
2.	General corporate purposes*	[●]	[●]
<b>Total</b>		<b>[●]</b>	<b>[●]</b>

\* To be finalised upon determination of the Offer Price and updated in the Prospectus prior to filing with the RoC.

The Net Proceeds will first be utilized for the Objects as set out above. In case of a shortfall in raising the requisite capital from the Net Proceeds towards meeting the objects of the Fresh Issue, our management may explore alternate options,

including utilisation of our internal accruals or further debt financing from existing or future lenders. We believe that such alternate arrangements would be available to fund any such shortfalls.

The requirement and deployment of funds indicated above is based on management estimates, current circumstances of our business and prevailing market conditions. The requirement and deployment of funds described herein has not been appraised by any bank or financial institution. We may have to revise our funding requirements and deployment from time to time on account of various factors, such as financial and market conditions, competition, business and strategy and interest/exchange rate fluctuations and other external factors, which may not be within the control of our management. This may entail rescheduling the proposed utilisation of the Net Proceeds and changing the allocation of funds from its planned allocation at the discretion of our management, subject to compliance with applicable law.

To the extent our Company is unable to utilise any portion of the Net Proceeds towards the aforementioned objects of the Offer, as per the estimated schedule of utilisation specified above, our Company shall deploy the Net Proceeds in the subsequent Fiscals towards the aforementioned objects in accordance with applicable law. If the actual utilisation towards any of the objects is lower than the proposed deployment, such balance will be used for general corporate purposes to the extent that the total amount to be utilized towards general corporate purpose will not exceed 25% of the gross proceeds from the Fresh Issue in accordance with applicable law.

### Details of Utilisation of Net Proceeds

The details of utilisation of the Net Proceeds are set forth below:

#### 1. *Prepayment/ repayment of all or a portion of the outstanding working capital facilities availed by our Company*

Our Company has entered into various financing arrangements with banks for loan facilities. For further details, including indicative terms and conditions of such loan facilities, see “*Financial Indebtedness*” beginning on page 238. As on December 1, 2018 the amount outstanding under the loan facilities entered into by our Company was ₹ 856.58 million on a standalone basis. Our Company may avail further loans after the date of this Draft Red Herring Prospectus.

Our Company proposes to utilise an aggregate amount of ₹ 750.00 million from the Net Proceeds towards repayment or prepayment of all or a portion of the loan facilities availed by our Company from various banks.

Given the nature of these borrowings and the terms of repayment, the aggregate outstanding amounts under these borrowings may vary from time to time and our Company may, in accordance with the relevant repayment schedule, repay or refinance some of its existing borrowings prior to Allotment. Accordingly, our Company may utilise the Net Proceeds for part prepayment of any such refinanced facilities or repayment of any additional facilities obtained by it. However, the aggregate amount to be utilised from the Net Proceeds towards prepayment or repayment of borrowings (including refinanced or additional facilities availed, if any), in part or full, would not exceed ₹ 750.00 million. The prepayment or repayment will help reduce our outstanding indebtedness and debt servicing costs, assist us in maintaining a favourable debt to equity ratio and enable utilisation of our internal accruals for further investment in business growth and expansion.

The following table provides details of working capital loans availed by our Company as on December 1, 2018, out of which all the facilities may be prepaid or repaid, in full or in part, from the Net Proceeds to the extent of an aggregate amount of ₹ 750.00 million:

S. No.	Name of lender	Applicable interest rate	Sanctioned amount as on December 1, 2018 (in ₹ million)	Outstanding amount as on December 1, 2018 (in ₹ million)	Repayment schedule/ Tenor	Purpose of availing the loan	Pre-payment penalty, if any
1.	Kotak Mahindra Bank Limited	The London inter-bank offered rate plus a spread based addition linked to disbursement. Bank has the right to reset interest and/or spread at the time of annual review.	198.50	179.08*	Tenor: 42 months including six months moratorium Repayment Schedule: 36 equal monthly instalments starting from the end of 7 <sup>th</sup> month of first disbursement	Capital expenditure for land and building, site development, purchase of plant and machinery, tools, computer and equipment and other miscellaneous fixed assets incurred/ to be incurred by the Company at its new manufacturing unit located at C-197,	<ul style="list-style-type: none"> <li>Prepayment prior to completion shall attract a penal charge on the outstanding loan amount.</li> <li>Company may prepay the loan without prepayment penalty from the proceeds of the Offer.</li> </ul>



S. No.	Name of lender	Applicable interest rate	Sanctioned amount as on December 1, 2018 (in ₹ million)	Outstanding amount as on December 1, 2018 (in ₹ million)	Repayment schedule/ Tenor	Purpose of availing the loan	Pre-payment penalty, if any
					under this facility	Phase-VII, Industrial Focal Point, Ludhiana-141 010, Punjab, India during the period April 1, 2016 till March 31, 2018	
2.	Kotak Mahindra Bank Limited	Marginal costs of basis lending rate plus a spread as applicable at the time of disbursement	150.00	150.00	Tenor: 54 months including six months moratorium Repayment Schedule: 48 equal monthly instalments starting from the end of 7 <sup>th</sup> month of first disbursement under this facility or the term loan availed from Kotak Mahindra Bank Limited whichever is earlier	Capital expenditure for procurement of plant and machinery pertaining to all the units/ plants which has been incurred/to be incurred during the period April 1, 2018 to March 31, 2019	<ul style="list-style-type: none"> <li>Prepayment prior to completion shall attract a penal charge on the outstanding loan amount.</li> <li>Company may prepay the loan without prepayment penalty from the proceeds of the Offer.</li> </ul>
3.	Citibank N.A.	12 month treasury bill plus spread as applicable on the date of disbursement	200.00	200.00	Tenor: 60 months including 12 months moratorium Repayment Schedule: Repayable on demand at the sole discretion of the bank and repayment to be done in 48 equal monthly instalments commencing from the 13 <sup>th</sup> month of the drawdown.	Financing capital expenditure/ movable fixed assets at its manufacturing facilities in Noida	<ul style="list-style-type: none"> <li>Prepayment penalty at the rate of 2% of the sanctioned amount or the principal outstanding amount whichever is higher, at the discretion of the bank</li> <li>Company may prepay the loan without prepayment penalty from the proceeds of the Offer</li> </ul>
4.	DBS Bank Limited	Present marginal cost of basis lending rate, i.e. 8.85% to 8.90% depending upon maturity period and subject to revision from time to time.	400.00	100.00	Repayment Schedule: Repayable on demand Tenor: Six months (maximum)	Working capital requirements	Prepayment charges at such rates based on the discretion of the bank, on the principal amount being repaid.
5.	RBL Bank Limited	One month marginal cost of basis lending rate calculated against the foreign currency at the	200.00	22.50	Repayment Schedule: Repayable on demand Tenor: Six	Working capital requirements	Nil

S. No.	Name of lender	Applicable interest rate	Sanctioned amount as on December 1, 2018 (in ₹ million)	Outstanding amount as on December 1, 2018 (in ₹ million)	Repayment schedule/ Tenor	Purpose of availing the loan	Pre-payment penalty, if any
		date of disbursement.			months (maximum)		
6.	Citibank N.A.	Two month treasury bill plus spread as applicable on the date of disbursement	700.00	205.00	Repayment Schedule: Repayable on demand Tenor: Six months to one year (maximum)	Working capital requirements of the Company or such other purpose as may be permitted by the bank	Company may prepay the loan without prepayment penalty from the proceeds of the Offer
	<b>Total</b>		1,848.50	856.58			

\* The outstanding loan balance is US\$ 2,571,553 which has been converted @ 69.64 as per the Reuters Rate as on November 30, 2018.

As certified by Rakesh Banwari & Co., Chartered Accountants, pursuant to their certificate dated December 2, 2018, our Company has utilized the above mentioned outstanding loan amounts as on December 1, 2018 for the purpose for which they were raised in terms of the financing arrangements entered into with the respective lenders, except ₹ 100 million out of the outstanding amount under the loan availed from Citibank N.A. (as described under serial number 3 in the table above), which has been drawn but is pending utilization.

Our Company may consider the following factors for identifying the loans that will be repaid out of the Net Proceeds:

1. Costs, expenses and charges relating to the facility, including interest rates involved and the amount of the loan outstanding,
2. Ease of operation of the facility,
3. Receipt of consents from the relevant lenders for the pre-payment of the concerned loan facilities and the terms and conditions of such consents, as applicable, and
4. Terms of pre-payment to lenders, if any, including levy of prepayment penalties.

In due course of business, due to various operational benefits, our Company may explore possibilities of other banks participating in existing loans either in full or in part, including the loans mentioned above. Some of our financing agreements provide for the levy of prepayment penalties, including penalties as may be specified by the lender at its discretion. In the event that there are any prepayment penalties required to be paid under the terms of the relevant financing agreements, such prepayment penalties shall be paid by our Company out of its internal accruals.

## 2. General Corporate Purposes

Our Company proposes to deploy the balance Net Proceeds, aggregating to ₹ [●] million, towards general corporate purposes, subject to such utilisation not exceeding 25% of the gross proceeds of the Fresh Issue, in compliance with the SEBI ICDR Regulations, including but not limited to maintenance and expansion of our manufacturing facilities, strategic initiatives, partnerships and joint ventures, strengthening of our marketing and distribution capabilities, meeting our working capital requirements, advertising and sales promotion activities across various platforms and increasing brand recognition among our existing and potential customers, meeting exigencies which our Company may face in the ordinary course of business, meeting fund requirements which our Company may face in the ordinary course of business, meeting expenses incurred in the ordinary course of business and any other purpose as may be approved by our Board or a duly appointed committee from time to time, subject to compliance with the necessary provisions of the Companies Act and SEBI ICDR Regulations. Our Company's management, in accordance with the policies of our Board subject to applicable law, will have flexibility in utilising any surplus amounts.

## Offer Expenses

The total Offer related expenses are estimated to be approximately ₹ [●] million. The Offer related expenses comprise listing fees, underwriting fees, selling commission and brokerage, fees payable to the BRLMs, legal counsels, Registrar to the Offer, Banker to the Offer including processing fee to the SCSBs for processing ASBA Forms submitted by ASBA Bidders procured by the Syndicate and submitted to SCSBs, brokerage and selling commission payable to Registered Brokers, RTAs and CDPs, printing and stationery expenses, advertising and marketing expenses and all other incidental expenses for listing the Equity Shares on the Stock Exchanges.

The costs, fees and expenses with respect to the Offer shall be borne by our Company and the Selling Shareholders in proportion to the Equity Shares issued or contributed by them in the Offer and as mutually agreed and in accordance with applicable law. Upon the successful completion of the Offer, or in the event the Offer is withdrawn or unsuccessful, each Selling Shareholder shall reimburse our Company for any expenses which were mutually agreed in accordance with applicable law, incurred by our Company on behalf of such Selling Shareholder. However, each Selling Shareholder shall have option to pay its respective expenses directly, and to the extent of such payment, such Selling Shareholder shall not be required to reimburse our Company.

The break-up for the Offer expenses are as follows:

Activity	Estimated expenses <sup>(1)</sup> (in ₹ million)	As a % of the total estimated Offer expenses <sup>(1)</sup>	As a % of the total Offer size <sup>(1)</sup>
BRLMs fees and commissions (including underwriting commission, brokerage and selling commission)	[●]	[●]	[●]
Commission/processing fee for SCSBs <sup>(2)</sup> and Bankers to the Offer	[●]	[●]	[●]
Brokerage and selling commission for Syndicate Members, Registered Brokers, RTAs and CDPs <sup>(3)</sup>	[●]	[●]	[●]
Registrar to the Offer	[●]	[●]	[●]
Legal advisors to the Offer	[●]	[●]	[●]
Advertising and marketing expenses	[●]	[●]	[●]
Regulators including Stock Exchanges (including SEBI filing fees, book building software fees)	[●]	[●]	[●]
Listing fees			
Printing and stationary			
Others	[●]	[●]	[●]
Miscellaneous	[●]	[●]	[●]
<b>Total estimated Offer expenses</b>	[●]	[●]	[●]

(1) Amounts will be finalised on determination of Offer Price and other details.

(2) Selling commission payable to the SCSBs on the portion for Retail Individual Investors and Non-Institutional Investors which are directly procured by the SCSBs, would be as follows:

Portion for Retail Individual Investors*	[●]% of the Amount Allotted (plus applicable taxes)
Portion for Non-Institutional Investors*	[●]% of the Amount Allotted (plus applicable taxes)

\* Amount Allotted is the product of the number of Equity Shares Allotted and the Offer Price.

Selling Commission payable to the SCSBs will be determined on the basis of the bidding terminal id as captured in the Bid Book of BSE or NSE.

No processing fees shall be payable by our Company and the Selling Shareholders to the SCSBs on the applications directly procured by them.

Processing fees payable to the SCSBs on the portion for Retail Individual Bidders and Non-Institutional Bidders which are procured by the members of the Syndicate/sub-Syndicate/Registered Broker/RTAs/ CDPs and submitted to SCSB for blocking, would be as follows:

Portion for Retail Individual Bidders*	₹[●] per valid application (plus applicable taxes)
Portion for Non-Institutional Bidders*	₹[●] per valid application (plus applicable taxes)

(3) Selling commission on the portion for Retail Individual Bidders, Non-Institutional Bidders which are procured by members of the Syndicate (including their sub-Syndicate Members), Registered Brokers, RTAs and CDPs would be as follows:

Portion for Retail Individual Bidders	[●]% of the Amount Allotted* (plus applicable taxes)
Portion for Non-Institutional Bidders	[●]% of the Amount Allotted* (plus applicable taxes)

\* Amount Allotted is the product of the number of Equity Shares Allotted and the Offer Price.

The Selling Commission payable to the Syndicate / Sub-Syndicate Members will be determined on the basis of the application form number / series, provided that the application is also bid by the respective Syndicate / Sub-Syndicate Member. For clarification, if a Syndicate ASBA application on the application form number / series of a Syndicate / Sub-Syndicate Member, is bid by an SCSB, the Selling Commission will be payable to the SCSB and not the Syndicate / Sub-Syndicate Member.

Bidding Charges payable to members of the Syndicate (including their sub-Syndicate Members), RTAs and CDPs on the portion for Retail Individual Bidders and Non-Institutional Bidders which are procured by them and submitted to SCSB for blocking, would be as follows: ₹ [●] plus GST, per valid application bid by the Syndicate (including their sub-Syndicate Members), RTAs and CDPs.

The selling commission and bidding charges payable to Registered Brokers the RTAs and CDPs will be determined on the basis of the bidding terminal ID as captured in the bid book of BSE or NSE.

The selling commission or charges, as the case may be, payable to SCSBs, members of the Syndicate (including their sub-Syndicate Members), Registered Brokers, RTAs and CDPs is subject to finalization of the Basis of Allotment.

### Interim use of Net Proceeds

The Net Proceeds of the Offer pending utilisation for the purposes stated in this section, shall be deposited only in scheduled commercial banks.

### Bridge Financing Facilities

Our Company has not raised any bridge loans from any bank or financial institution as on the date of this Draft Red Herring Prospectus, which are proposed to be repaid from the Net Proceeds.

### **Monitoring Utilization of Funds**

Our Company shall appoint a monitoring agency in relation to the Fresh Issue, if required under the SEBI ICDR Regulations prior to filing of the Red Herring Prospectus. Our Board will monitor the utilisation of the Net Proceeds through its Audit Committee. Our Company will disclose the utilisation of Net Proceeds under a separate head in our balance sheet along with relevant details for all sum amounts that have not been utilised, for such fiscal periods as required under the SEBI ICDR Regulations, SEBI Listing Regulations and other applicable law. Our Company will indicate investments, if any, of unutilized Net Proceeds in the balance sheet of our Company for the relevant Fiscals subsequent to receipt of listing and trading approvals from the Stock Exchanges.

Pursuant to the SEBI Listing Regulations, our Company shall disclose to the Audit Committee of our Board, the uses and applications of the Net Proceeds, on a quarterly basis. Our Company shall on an annual basis, prepare a statement of funds utilised for purposes other than those stated in this Draft Red Herring Prospectus and place it before the Audit Committee of our Board, as required under applicable law. Such disclosure shall be made only until such time that all the Net Proceeds have been utilised in full. The statement shall be certified by the statutory auditors of our Company.

Furthermore, in accordance with the Regulation 32(1) of the SEBI Listing Regulations, our Company shall furnish to the Stock Exchanges on a quarterly basis, a statement indicating (i) deviations, if any, in the actual utilisation of the proceeds of the Offer from the Fresh Issue as stated above; and (ii) details of category wise variations in the actual utilisation of the proceeds of the Fresh Issue from the objects of the Fresh Issue as stated above. This information will also be published in newspapers simultaneously with the interim or annual financial results, and explanation for such variation (if any) will be included in our Directors' report, after placing the same before the Audit Committee of our Board.

### **Variation in Objects**

In accordance with Section 13(8) and Section 27 of the Companies Act, 2013, Regulation 59 and Schedule XX of the SEBI ICDR Regulations and applicable rules, our Company shall not vary the objects of the Offer without our Company being authorised to do so by our Shareholders by way of a special resolution through postal ballot. In addition, the notice issued to our Shareholders in relation to the passing of such special resolution (the "**Postal Ballot Notice**") shall specify the prescribed details as required under the Companies Act and applicable rules. The Postal Ballot Notice shall simultaneously be published in the newspapers, one in English and one in the vernacular language of the jurisdiction where our Registered Office is situated. Our Promoters or controlling Shareholders will be required to provide an exit opportunity to such Shareholders who do not agree to the proposal to vary the objects, at such price, and in such manner, as prescribed in Regulation 59 and Schedule XX of the SEBI ICDR Regulations.

### **Appraising Entity**

None of the objects of the Offer for which the Net Proceeds will be utilised have been appraised by any bank/financial institution.

### **Other Confirmations**

Apart from the portion of the proceeds from the Offer for Sale which shall be paid to Meher Soni and Pamela Soni, members of our Promoter Group, in proportion to the Equity Shares being offered by them through the Offer, no part of the proceeds from the Offer will be paid by us to our Promoters, other members of our Promoter Group, Group Company, Directors, or Key Managerial Personnel. Our Company has not entered into and is not planning to enter into any arrangement/agreements with our Promoters, members of our Promoter Group, Group Company, Directors and Key Managerial Personnel in relation to the utilization of the Net Proceeds. Further, except in the ordinary course of business, there is no existing or anticipated interest of such individuals and entities in the objects of the Fresh Issue as set out above.

## BASIS FOR OFFER PRICE

The Price Band/ Offer Price will be determined by our Company and the Investor Selling Shareholders in consultation with the BRLMs, on the basis of assessment of market demand for the Equity Shares offered through the Book Building Process and on the basis of quantitative and qualitative factors as described below. The face value of the Equity Shares is ₹ 10 each and the Offer Price is [●] times the face value at the lower end of the Price Band and [●] times the face value at the higher end of the Price Band. Investors should also refer to “Risk Factors”, “Our Business”, “Financial Statements” and “Management’s Discussion and Analysis of Financial Condition and Results of Operations” on pages 21, 113, 162 and 241, respectively, to have an informed view before making an investment decision.

### Qualitative Factors

Some of the qualitative factors which form the basis for computing the Offer Price are:

- A leading market presence in the 3PL and PMP product verticals;
- Strong global service delivery model, through strategically located facilities in India, the U.S. and Europe;
- Long-term relationships with marquee global customers, including major OEMs;
- Backward and forward integrated operations;
- Concept-to-supply solutions across the OHV component value chain;
- Strong financial position and diversified business model with a proven ability to sustain industry cycles; and
- Experienced and qualified team of professionals.

For further details, see “Our Business – Our Strengths” on page 114.

### Quantitative Factors

The information presented below relating to our Company is based on the Restated Financial Statements.

Some of the quantitative factors which may form the basis for calculating the Offer Price are as follows:

#### A. Basic and Diluted Earnings per Share (“EPS”) at face value of ₹ 10 each:

##### As per Restated Financial Statement:

Year ended	Basic EPS (₹)	Diluted EPS (₹)	Weight
March 31, 2018	12.14	11.86	3
March 31, 2017	6.01	5.88	2
March 31, 2016	10.14	9.91	1
<b>Weighted Average</b>	<b>9.63</b>	<b>9.41</b>	
<b>Six months period ended September 30, 2018*</b>	<b>10.02</b>	<b>9.79</b>	

\* Not Annualised

##### Notes:

1. Earning per shares (EPS) calculation is in accordance with the notified Indian Accounting Standard (Ind AS) 33 'Earnings per share' prescribed by the Companies (Indian Accounting Standards) Rules, 2015. The ratios have been computed as below:
  - a) Basic earnings per share (INR) = Net profit after tax attributable to owners of the Company, as restated/ Weighted average number of equity shares outstanding during the year
  - b) Diluted earnings per share (INR) = Net profit after tax attributable to owners of the Company, as restated/ Weighted average number of potential equity shares outstanding during the year
2. Weighted average number of equity shares is the number of equity shares outstanding at the beginning of the year adjusted by the number of equity shares issued during the year multiplied by the time weighting factor. The time weighting factor is the number of days for which the specific shares are outstanding as a proportion of total number of days during the year.

#### B. Price/Earning (“P/E”) ratio in relation to Price Band of ₹ [●] to ₹ [●] per Equity Share:

Particulars	P/E at the Floor Price (no. of times)	P/E at the Cap Price (no. of times)
Based on basic EPS for Financial Year 2018 on Restated Financial Statements	[●]	[●]
Based on diluted EPS for Financial Year 2018 on Restated Financial Statements	[●]	[●]

### Industry Peer Group P/E ratio

There are no listed entities in India whose business portfolio is comparable with that of our business.

### C. Return on Net Worth (“RoNW”)

As per the Restated Financial Statements:

Financial Year ended / Period ended	RoNW (%)	Weight
March 31, 2018	14.69	3
March 31, 2017	8.34	2
March 31, 2016	15.20	1
<b>Weighted Average</b>	<b>12.17</b>	
<b>Six months period ended September 30, 2018*</b>	<b>11.37</b>	

\* Not Annualised

Notes:

1. RoNW is computed as Net profit after tax attributable to the owners of the Company, as restated divided by Net worth as restated as at year end.
2. Net worth means the aggregate value of the paid up share capital of the Company and all reserves created out of profits and securities premium account as per Restated Statement of Assets and Liabilities of the Company.

### D. Net Asset Value per Equity Share (Face value of ₹ 10 each)

Net Asset Value per Equity Share	Consolidated (₹)
As on September 30, 2018	86.07
After the Offer	[●]
Offer Price	[●]

Notes:

1. Offer Price per Equity Share will be determined on conclusion of the Book Building Process.
2. Net Asset Value per Equity Share has been computed as net worth, as restated at the end of the year divided by total number of Equity Shares outstanding at the end of the year.
3. Net worth means the aggregate value of the paid up share capital of the Company and all reserves created out of profits and securities premium account as per Restated Statement of Assets and Liabilities of the Company.

### Comparison with Listed Industry Peers

Our Company does not have any listed industry peers in India.

**The Offer price is [●] times of the face value of the Equity Shares.**

The Offer Price of ₹ [●] has been determined by our Company and the Investor Selling Shareholders in consultation with the BRLMs, on the basis of demand from investors for Equity Shares through the Book Building Process and, is justified in view of the above qualitative and quantitative parameters.

Investors should read the above mentioned information along with “Risk Factors”, “Our Business”, “Financial Statements” and “Management’s Discussion and Analysis of Financial Condition and Results of Operations” on pages 21, 113, 162 and 241, respectively, to have a more informed view. The trading price of the Equity Shares could decline due to the factors mentioned in the “Risk Factors” on page 21 and you may lose all or part of your investments.

## STATEMENT OF SPECIAL TAX BENEFITS

To,

**The Board of Directors**  
**Uniparts India Limited**  
Gripwel House, Block 5, C6 & 7  
LSC Vasant Kunj  
New Delhi - 110 070 (India)

Dear Sirs,

**Subject: Statement of possible special tax benefits available to Uniparts India Limited (“the Company”), its Material Subsidiaries and shareholders prepared in accordance with applicable requirements of the Securities and Exchange Board of India (Issue of Capital and Disclosure Requirements) Regulations, 2018 (“SEBI ICDR Regulations”)**

This report is issued in accordance with the terms of our engagement letter dated October 03, 2018

We hereby report that the accompanying Statement states the possible special tax benefits available to the Company and its Material Subsidiaries, Gripwel Fasteners Private Limited, Uniparts USA Limited and Uniparts Olsen Inc. (i.e. subsidiaries of the Company determined to be material in accordance with the criteria specified in Schedule VI(11)(I)(A)(ii)(b) of the SEBI ICDR Regulations (“**Material Subsidiaries**”)), and shareholders of the Company (hereinafter referred to as “the **Statement**”) under the Income Tax Act, 1961 (read with Income Tax Rules, circulars, notifications) as amended by the Finance Act, 2018 presently in force in India (together referred to as the “**Direct Tax Laws**”), Goods and Service Tax Act, 2017 and Customs Act, 1962 (read with rules, circulars, notifications) presently in force in India (together referred to as the “**Indirect Tax Laws**”), The Iowa Industrial New Jobs Training (260E) program and Work Opportunity Tax Credit in USA. These possible special tax benefits are dependent on the Company, the Material Subsidiaries and / or the Company’s shareholders fulfilling the conditions prescribed under the relevant Tax Laws, Indirect Tax Laws and other laws. Hence, the ability of the Company, the Material Subsidiaries or the Company’s shareholders to derive these possible special tax benefits is dependent upon their fulfilling such conditions, which is based on business imperatives the Company and the Material Subsidiaries may face in the future and accordingly, the Company, the Material Subsidiaries or the Company’s shareholders may or may not choose to fulfil.

The benefits discussed in the enclosed Statement are not exhaustive and only cover the possible special direct and indirect tax benefits available to the Company, the Material Subsidiaries and the Company’s shareholders. The Statement is neither designed nor intended to be a substitute for professional tax advice and each investor is advised to consult his or her own tax consultant with respect to the specific tax implications arising out of their participation in the proposed initial public offering of equity shares of the Company.

We do not express any opinion or provide any assurance as to whether:

- i) the Company, the Material Subsidiaries or the Company’s shareholders will continue to obtain these possible special tax benefits in future; or
- ii) the conditions prescribed for availing the possible special tax benefits where applicable, have been/would be met with.

The contents of this Statement are based on the information, explanations and representations obtained from the Company and on the basis of our understanding of the business activities and operations of the Company. No assurance is given that the revenue authorities/ courts will concur with the views expressed herein. Our views are based on the existing provisions of law and its interpretation, which are subject to change from time to time. We do not assume responsibility to update the views consequent to such changes.

We conducted our examination in accordance with the “Guidance Note on Reports or Certificates for Special Purposes (Revised 2016)” (“**Guidance Note**”) issued by the Institute of Chartered Accountants of India. The Guidance Note requires that we comply with ethical requirements of the Code of Ethics issued by the Institute of Chartered Accountants of India.

We hereby give consent to include this Statement in the draft red herring prospectus, red herring prospectus and prospectus in connection with the proposed initial public offering of the Company.

**For RAKESH BANWARI & CO.**  
*Chartered Accountants*  
**Firm Registration No.: 009732N**

**RAKESH AGGARWAL**  
Proprietor  
Membership No. 088193

Place: New Delhi  
Date: November 23, 2018



## STATEMENT OF POSSIBLE SPECIAL TAX BENEFITS AVAILABLE TO THE COMPANY, MATERIAL SUBSIDIARIES AND COMPANY'S SHAREHOLDERS

Outlined below are the possible special tax benefits available to the Company, its Material Subsidiaries and Shareholders of the Company under the direct and indirect Tax Laws in force in India and Abroad (i.e. applicable for the Financial Year 2018-19 relevant to the Assessment Year 2019-20).

### A. Special Tax Benefits to the Company and its Material Subsidiaries

#### I. DIRECT TAX

1. The unit of the Company at Vishakhapatnam and a factory of its subsidiary, Gripwel Fasteners Private Limited at Noida, situated in SEZs, are eligible for deduction under sec. 10AA of the Income Tax Act, 1961 to the extent of 50% of the profits derived by the Unit till A.Y. 2023-24 subject to the condition that 50% of the profit of the Unit as debited to the Profit and Loss Account of the previous year in respect of which the deduction is to be allowed and credited to a reserve account (to be called the "Special Economic Zone Re-investment Reserve Account) and utilized for the purposes of the business of the Company as prescribed hereunder:
  - (i) The amount credited to 'Special Economic Zone Reinvestment Reserve Account' is required to be utilized only for the purpose of purchase of plant or machinery in SEZ units only. Such newly acquired plant or machinery should be first put to use before expiry of 3 years following the previous year in which the said reserve has been created.
  - (ii) Further, the amount credited to 'Special Economic Zone Reinvestment Reserve Account', until the acquisition of the plant or machinery as mentioned in point 1 above, can be used for the purpose of business of the undertaking. However, the same cannot be used for distribution by way of dividend or profits or for remittance of profits outside India or for creation of any assets outside India.
2. The Subsidiary of the Company, namely Uniparts Olsen Inc. ("UOI") situated in USA is eligible for the following tax benefits-
  - (i) **Iowa Training Program** – The Iowa Industrial New Jobs Training (260E) program provides businesses expanding Iowa's workforce with new employee training. Employees from UOI attend classes at one of Iowa's 15 community colleges and their tuition is covered by bonds sold by the college. When UOI withholds Iowa state income tax on behalf of the employee, a portion of the withholding is diverted away from the state and is paid to the college instead. The payment to the college is applied towards the balance of the bonds. UOI is eligible for this program because it is located in Iowa and it is engaged in interstate or intrastate commerce for the purpose of manufacturing, processing, assembling products, warehousing, wholesaling, or conducting research and development.
  - (ii) **Work Opportunity Tax Credit** – This is a Federal tax credit available to UOI for hiring individuals from certain targeted groups who have consistently faced significant barriers to employment. WOTC joins other workforce programs that incentivize workplace diversity and facilitate access to good jobs for American workers.

#### II. INDIRECT TAX

1. **Goods and Service Tax (GST)** – The unit of the Company at Vishakhapatnam and a factory of its subsidiary, Gripwel Fasteners Private Limited, situated in SEZs, are eligible for import of goods and services without payment of GST.
2. **Customs Duty** - The unit of the Company at Vishakhapatnam and a factory of its subsidiary, Gripwel Fasteners Private Limited, situated in SEZs, are eligible for import of goods and services without payment of import duty.

### B. Special Tax Benefits to the Shareholders of the Company

There are no special tax benefits available to the Shareholders of the Company.

## SECTION IV: ABOUT OUR COMPANY

### INDUSTRY OVERVIEW

*Other than the information under “– Hydraulic Cylinders Market” beginning on page 109, which is derived from a report titled “Global Mobile Hydraulic Equipment Market, Forecast to 2023 – Renewed Investments in Infrastructure, Logistics, and Energy to Support the Recovery in the Mobile Hydraulic Equipment Sector” dated July 2018 prepared by Frost & Sullivan (“F&S Report”), the information in this section has been derived from the report titled “Global market assessment of 3PL and PMP products in Agriculture and Construction Equipments” dated November 29, 2018, prepared by CRISIL Research, a division of CRISIL Limited (“CRISIL” or “CRISIL Research” and such report, the “CRISIL Report”). In respect of information derived from the F&S Report, the F&S Report states that Frost & Sullivan is not responsible for any incorrect information supplied to it by manufacturers and users and the qualitative market information is primarily based on interviews and is therefore, subject to fluctuation. Further, all information contained in the CRISIL Report has been obtained by CRISIL from sources believed by it to be accurate and reliable. CRISIL obtains information for its analysis from sources it considers reliable, but does not guarantee the accuracy or completeness of its analysis or any information contained in the CRISIL Report. Further, the CRISIL Report was prepared on the basis of information as of specific dates which may no longer be current or reflect current trends, and opinions in the CRISIL Report may be based on estimates, projections, forecasts and assumptions that may prove to be incorrect. CRISIL has confirmed that certain third-party information used or cited in the CRISIL Report has been obtained from publicly available information and acknowledgements of sources have been given wherever necessary in the CRISIL Report. In other cases, CRISIL has obtained specific consent from the persons/companies having intellectual rights in the information for use of such information in the CRISIL Report. CRISIL and its affiliates make no representation or warranty, either express or implied, with respect to the information or analysis from the CRISIL Report, including without limitation the implied warranties of fitness for a particular purpose and merchantability and CRISIL specifically disclaims any such warranty. The CRISIL Report is not a comprehensive evaluation of the industry, our Company or the Equity Shares and all material within the CRISIL Report should be deemed as expressions of opinion which are subject to change without notice.*

*All data included herein is from the CRISIL Report unless specifically mentioned otherwise.*

#### World Economy Overview and Outlook

The global economy continues to expand from 2016 onwards, with growth rates in key economies seeing improvement over the past couple of years. Global GDP is forecasted to grow at 3.7% in 2018 and 2019, according to IMF. However, trade measures being implemented by the US may subdue economic activity in 2019 and beyond; while weaker credit growth and rising trade barriers could reduce economic growth in China.

The US recently imposed tariffs on a variety of imports, including imports on certain goods from China, resulting in its trading partners thinking of protective measures of their own. Intensification of trade tensions and the associated policy uncertainty could lead to adverse business and financial market sentiments, as well as lower trade and investment activities. Higher trade barriers would also disrupt global supply chains, delay the spread of new technologies, and make consumer goods less affordable.

While financial market conditions remain supportive in advanced economies, they could tighten if trade tensions intensify, or high inflation in the US triggers a monetary policy response. Tighter financial conditions in advanced economies could cause disruptive portfolio adjustments, sharp exchange rate movements and further reduce capital inflows to emerging markets. Beyond 2019, growth in most advanced economies is expected to decrease as a result of slower expansion in working-age populations and lower productivity gains. Global growth is expected to remain steady at 3.7% in 2020, and slow to 3.6% by 2023, largely reflecting a slowdown in growth in advanced economies. However, growth projections remain strong for emerging markets across Europe and Asia up to 2023.

GDP growth in select economies - Constant prices

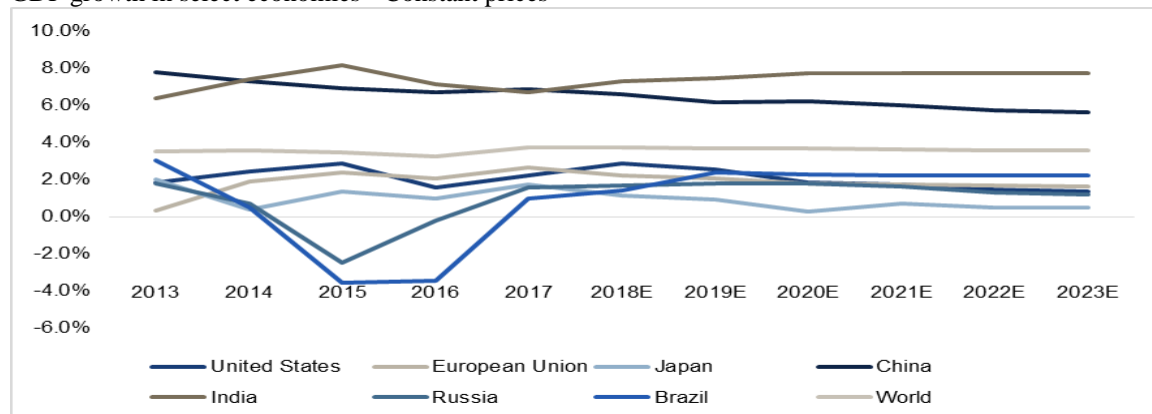

## ***Agricultural sector***

Agricultural production grew strongly across commodities between 2007-2017, and reached record levels for most cereals in 2017, according to the OECD. Much of the demand over the past decade came from China as a result of rising income levels. This demand is now decelerating, and new sources of global demand are not sufficient to maintain growth at the same level. Going forward, population growth is expected to be the main driver of consumption growth of most commodities. However, per capita consumption for many commodities is estimated to be flat at a global level until 2027. Prices of agricultural commodities are also expected to remain low. Global agricultural production is forecast to increase by 20% between 2017-2027, driven by intensification and efficiency gains, and partially through an enlargement of the production base.

## ***Industrial sector***

After rapid growth in 2017, global industrial production and trade volumes have slowed. However, overall sentiment has generally remained positive, despite the intensification of trade disputes. A core element of the growth in 2017 was an upsurge in investment. Global imports and investment growth rates were the highest since the 2010-2011 rebound from the global financial crisis, at around 5%. Although the global pace of investment is expected to ease, investment growth in developing economies is forecast to remain robust at around 5.5% per year up to 2023.

## **Geography-Wise Economic Outlook**

### **United States**

According to the IMF, GDP growth in the US is expected to reach 2.9% in 2018, compared to 1.6% in 2016 and 2.2% in 2017, driven by fiscal stimulus after eight years of expansion and liberal financial conditions even after monetary tightening. The GDP value in the US was approximately US\$ 19.5 trillion in 2017. Growth is expected to decrease to 2.5% in 2019 and 1.8% in 2020, as the fiscal stimulus begins to unwind. Recent trade measures are also expected to weigh on economic activity. Strong domestic demand is expected to push the economy above full employment and increase imports and the current account deficit. By 2023, growth is expected to decrease to 1.4%, as working population growth continues to slow and productivity growth remains moderate.

### ***Agricultural Sector***

Agriculture accounted for ~1% of US GDP in 2017 and its share has remained near this mark over the last decade. Agricultural output has grown at ~1.6% annually between 2007 and 2017, driven primarily by technological developments leading to long-term growth in agricultural productivity. Due to decreasing commodity prices output declined at an annual rate of 8.5% between 2013-2016. However, in 2017, agricultural output grew by 2.6% YoY. Agricultural cereal yields have grown by 2.4% from 2006 to 2016. In 2016, US cereal yield was 8,143 kg per hectare, much higher than the world average of 3,967 kg per hectare, mainly due to increased productivity arising from technological advances and innovation

### ***Industrial Sector***

Industry share in GDP has decreased from 21.4% in 2007 to 18.2% in 2017, primarily due to strong growth in the services sector. The sector grew at a CAGR of 1% between 2013-2016, mainly due to sluggish economic growth. However, it witnessed a YoY growth of 5.6% in 2017 driven by growth in the manufacturing sector, and tax reforms leading to increased reinvestment in the US economy. The manufacturing sector is poised to grow at a CAGR of 2.8% between 2018-2021, driven by a rebound in mining amid recovering commodity markets, as well as expected growth in the automotive sector. Business investment and construction activity are also expected to strengthen in the coming years, providing a tailwind to the sector

### **Europe**

According to the IMF, GDP of the European Union is expected to grow by 2.2% in 2018 and 2% in 2019, compared to 2.7% in 2017. The GDP value for the European Union was approximately US\$ 17.3 trillion in 2017. The Euro area is expected to continue to grow, with the GDP growth forecast at 2.0% in 2018, compared to 2.4% in 2017, reflecting a weaker-than-expected performance in the first half of the year. Growth is forecast to slow to 1.9% in 2019. Healthy consumer spending, job creation, and a supportive monetary policy are expected to continue to fuel strong demand. However, growth is projected at about 1.4% in 2023, constrained by slow productivity growth and unfavourable demographics.

In France, growth is expected to reach 1.6% in 2018 and 2019 (compared to 2.3% in 2017), reflecting softer external demand. In Germany, growth is forecast at 1.9% percent in 2018 and 2019 (compared to 2.2% in 2016 and 2.5% in 2017) due to a slowdown in exports and industrial production. Italy's growth forecast is estimated at 1.2% in 2018 and 1% in 2019 (compared to 1.5% in 2017), due to a deterioration in external and domestic demand and uncertainty about the new government's policy agenda.

UK GDP growth is projected to slow to 1.4% in 2018 and 1.5% in 2019 from 1.7% in 2017. The country witnessed weak growth in the first quarter of 2018, primarily due to weather-related factors. The growth forecast for 2023 is 1.6% due to the anticipated higher barriers to trade following Brexit.

#### *Agricultural Sector*

Agriculture accounted for 1.4% of EU GDP in 2017, a slight decrease from 1.5% in 2007. Agricultural output increased at a CAGR of 1.2% between 2013-2017. Agricultural cereal yields grew at a low 1% annually from 2006 to 2016, as a result of fewer farmers and less arable land. The sector is challenged by the migration of population from rural to urban areas. Employment in agriculture has declined from 8% of total employment in the 1990s to ~4% currently.

#### *Industrial Sector*

Industry share in GDP has decreased from 23.8% in 2007 to 21.9% in 2017, primarily due to growth in the services sector. Industrial output grew at a CAGR of 2.4% between 2013-2016, and at 3.3% YoY in 2017. There has been a rebound in construction activity due to improving economic conditions, as is visible from the growth in construction output. Construction demand is set to rise further in 2018 and 2019, driven by private and public sector demand for building and civil engineering projects, as well as higher demand for residential construction. The manufacturing production index also grew from 95.2 in 2013 to 105.4 in 2017, as a result of strong domestic and overseas demand. The sector is expected to continue to grow in the coming years. However, it may be hindered by constrained production capacities of manufacturers

### **Japan**

According to the IMF, Japan's GDP growth is forecast to fall to 1.1% in 2018 and 0.9% in 2019 from 1.7% in 2017 mainly due to contraction observed in the first quarter of 2018. The GDP value in Japan was approximately US\$ 4.9 trillion in 2017. Medium-term growth is expected to be hindered by unfavourable demographics and a decline in the labour force, reaching 0.5% in 2023.

#### *Agricultural Sector*

The share of agriculture in GDP has decreased slightly from 1.1% in 2007 to 1% in 2017. Agricultural productivity is high, with cereal yields at 4,976 kg per hectare in 2016 compared to the world average of 3,967 kg per hectare, mainly due to the adoption of terrace farming due to lack of arable land, as well as widespread use of agricultural technology. Agricultural output declined by 7.1% between 2013-2016, as the sector remained constrained by Japan's low economic growth and ageing population. Also, the sector lacks economies of scale due to the small size of mostly family-run holdings. Going forward, the sector is expected to benefit from a major shift from family-owned businesses to corporate operators employing a growing number of younger, tech-savvy farmers. The government is also looking to initiate reforms to lower prices for fertilisers and farm equipment to promote the competitiveness of Japanese agriculture.

#### *Industrial Sector*

The contribution of industry has decreased marginally from 29.9% in 2007 to 29.7% in 2017. Industrial output grew at a CAGR of 2.2% between 2013-2016. The country's working age population continues to decline, and labour as well as capital productivity are lower compared to other developed economies. However, in 2017, employment in the manufacturing sector averaged 10 million workers (Jan-Aug) for the first time since 2010, as companies continued to bring more production home and exports recovered on the back of a mild global economic recovery. Japan's exports to China and Asia also hit record levels in 2017. Robust external demand could lead to higher business investments and consumer spending, sparking economic growth. The Japanese Ministry of Economy, Trade and Industry (METI) has identified advanced manufacturing as one of Japan's key growing sectors, predicting that it will reach JPY 30 trillion (US\$270 billion) by 2020.

### **India**

GDP growth dipped in 2017 because of domestic disruptions; however, the economy is in recovery mode as the twin impact of demonetization and glitches during implementation of Goods and Services Tax (GST) are fading away. The GDP value in India was approximately US\$ 2.6 trillion in 2017. Improvement in growth has been broad-based, supported by government consumption (11.7% growth over 2016) as well as private consumption (5.9% growth over 2016) - external sector continued to remain a drag with imports growing at a much faster pace (11.4% growth over 2016) as compared to exports (6.5% growth over 2016) - exporters were also impacted by GST and demonetisation. On supply side, Gross Value Added (GVA) grew by 6.1% over 2016 supported by services sectors.

CRISIL Research expects India's GDP to grow at 7.5% for FY19, supported by a third straight year of normal and fairly reasonably distributed monsoon, ironing out of Goods and Services Tax (GST) - related issues, fading of demonetisation impact, budgetary support to the rural economy, and a low-base effect

## *Agricultural Sector*

Agriculture has grown at 3% CAGR during 2012-2017 and declined marginally in terms of its share in the GVA. Production of food-grains touched a record high of 284.8 million tonnes in 2017-2018 on the back of last year's normal monsoon, according to the fourth advance estimates of crop production. Production of rice is estimated at 112.9 million tonnes in 2017-2018, 2.9% higher than the previous year, production of wheat touched 99.7 million tonnes, about 1.2% higher than the previous year. Agriculture is expected to grow at a steady pace, aided by government support in the form of minimum support prices (MSP) for crops, development of rural agricultural markets with all-weather road connectivity, improving crop insurance coverage etc.

## *Industrial Sector*

Manufacturing, which has grown at 7-8% CAGR during 2012-2017 has gained marginally in terms of its share in the GVA – pay commission revisions have pulled up demand across segments like auto, fast-moving consumer goods (FMCG); also good monsoons for past 3 years has propped up rural demand.

The manufacturing sector is also expected to witness growth, particularly in sectors like pharmaceuticals, automobiles, cement, FMCG, etc. - while government's target of raising manufacturing share in GDP to 25% by 2022 is an uphill task, India's domestic market can provide the requisite opportunity for growth; fading impact of GST and demonetisation is also expected to lift the manufacturing sector.

### **3-Point Linkage (3PL) Market**

The three-point linkage most often refers to the way ploughs and other implements are attached to an agricultural tractor. The three points resemble either a triangle, or the letter A. Three point attachments is the simplest and the only statically determinate way of joining two bodies in engineering.

The three-point linkage systems consist of different assemblies that are attached to an agricultural tractor. It forms a group of assemblies allowing attaching an implement like a plough to the tractor at 3 coupling points forming a triangle.

It connects the implement in a manner to the tractor that the tractor and implement becomes one unit allowing the tractor to operate the implement. The 3-point linkage transfers the entire load which can be a multiple of the implement weight between the tractors and implement.

Three-point linkages are composed of three movable arms. The two lower arms—lower links or draft links—are controlled by the hydraulic system, and provide lifting, lowering, and even tilting to the implement. The upper centre arm—called the top link—is movable, but is not powered by the tractor's hydraulic system and acts like a connecting rod. Each arm has an attachment device to connect implements to the hitch.

The features of a 3-point linkage design are highly dependent on the market they have to service. There are fundamental differences in the features of an entire system and the design of the components interfacing with the implement. The design features can be classified as:

- **Standard:** Basic design of all components with simple joints to connect the implement to the tractor. It is used on low HP tractors and in the economy segment.
- **Telescopic:** In this design the lower links do not have standard ball joints at the interfacing joining the implement but a device which allows to disengage a slip end which then can be joined to the implement by having the tractor only positioned in a certain proximity to the implement. In this configuration the top link is usually a standard design with basic ball joints at the implement end.
- **Quick Coupler:** The lower links are equipped with a claw allowing the operator to remain on his operator station and to connect or disconnect an implement from his seat. This has significant advantages in regard to safety and comfort, in particular considering the size and weight of implements connected to a tractor.
- **Frame Coupler:** This is a version of a quick coupler using an A frame / single piece joining with the implement. This configuration is primarily a North American specification and a limited relevance globally.

Further, there are five different linkage sizes, called categories. The higher category linkages have sturdier lift arms and larger connector pins. There is some flexibility in the tractor HP at which one category linkage ends and the next begins. Globally 3PL industry follows ISO: 730.

### **Global 3PL Market**

The world market for 3-point linkages (3PL) is estimated at US\$ 390-410 million in 2017, grew at a CAGR of around 1% during 2013-2017. 3PL was standardised following a global industry-wide agreement among tractor and implement

manufacturers in the 1960s. Hence, a major driver of 3PL demand is tractors, which is, in turn, a function of agriculture growth. Higher agriculture growth boosts farm incomes, resulting in higher tractor sales.

Europe, contributing nearly 9% of the world tractor volume, is one of the key demand geographies for 3PL - contributing almost 26% of the world demand for such parts in value.

India and China together account for around 56% of world tractor production but generate an estimated demand of only 38% for 3PL. This is primarily due to

- higher ratio of lower HP tractors in the total population
- lower prices of 3PL in these regions

North America being one of the most mature tractor markets contributes around 8% of world tractor demand and is estimated to contribute around 15% of the total demand for 3PL in the world.

**World 3PL Market (US\$ 380-400 mn) in 2013**

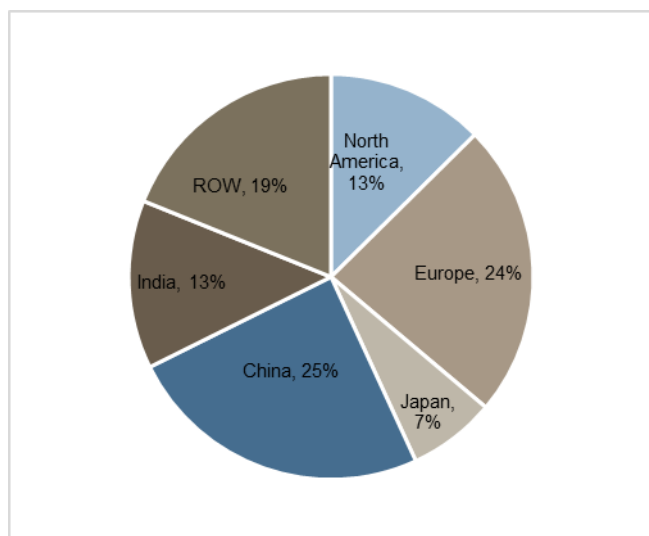

Source: Industry reports, CRISIL Research

**World 3PL Market (US\$ 390-410 mn) in 2017**

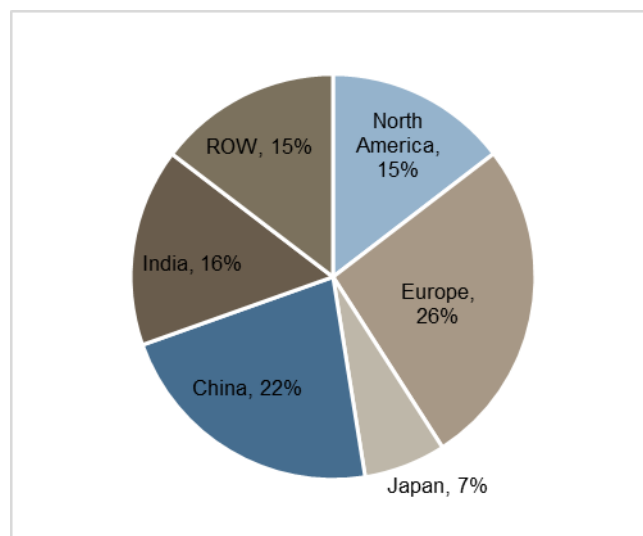

Source: Industry reports, CRISIL Research

**World 3PL Market (US\$ 580-600 million) in 2022**

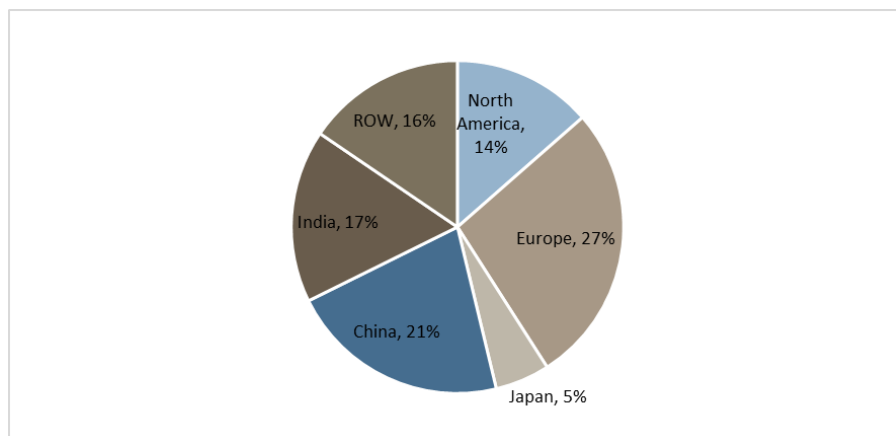

Source: Industry reports, CRISIL Research

Note: ROW includes tractor production in all the remaining geographies barring the five major geographies mentioned above

**Global Tractor Production**

During 2013-2017, the world tractor production marginally declined on the back of a slowdown in major geographies like Japan and China. China’s arable land declined for the fourth consecutive year primarily due to new construction, natural disasters and environmental requirements, as well as changes in agricultural production, leading to a decline of 4.4% in tractor production during the same period. However, tractor production is expected to pick up across all the geographies and is estimated to grow at nearly 4-6% during 2017-2022.

On the other hand, although India and China have a share of nearly 56% of world tractor production their share in global 3PL demand is only around 38%. This is primarily due to two key reasons; higher ratio of lower HP tractors in the total population and lower per assembly price of 3PL in these regions.

North America, being one of the most mature tractor markets, contributes around 8% of world tractor demand, and is estimated to contribute almost 15% of the total demand for 3PL in the world in 2017. The demand for 3PL (which is intricately linked to tractor demand) is set to grow at a steady, healthy pace. During 2017-2022, global tractor production is estimated to grow at a CAGR of 4-6%.

Nearly 80% of the tractors produced in 2022 will be in North America, India and China (with India and China accounting for almost 72% of total tractor output). These geographies are expected to grow at a CAGR of 4-6% during 2017-2022. On the other hand, Europe is expected to witness 5-7% growth during 2017-2022 and the Japanese tractor markets are predicted to remain flat in the near future. In 2017, Europe produced 9% of the world’s tractors; by 2022, its share is expected to be 11%.

The ROW group (Rest of the world countries), which accounts for around 21% of world tractor production, is also estimated to grow at a CAGR of around 4-6% because of an increase in tractor production in Russia.

*Compound Annual Growth Rates (CAGR) - Tractors*

CAGR	NORTH AMERICA	EUROPE	JAPAN	CHINA	INDIA	TOTAL
Review (2013-2017)	1.8%	0.9%	-3.4%	-4.4%	2.2%	-1.3%
Outlook (2017-2022)	3.1%	5.5%	0.3%	4%	6%	4.7%

Source: Industry, CRISIL Research

*World Tractor Production (2013) -Geography-wise split*

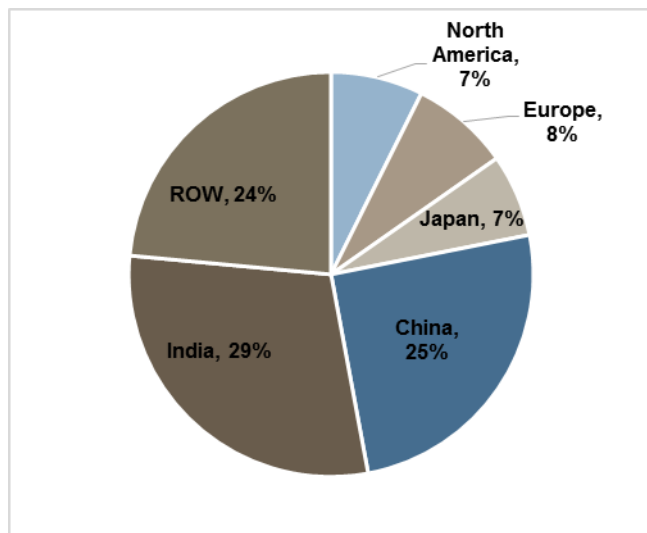

Source: Industry, CRISIL Research

*World Tractor Production (2017) – Geography-wise split*

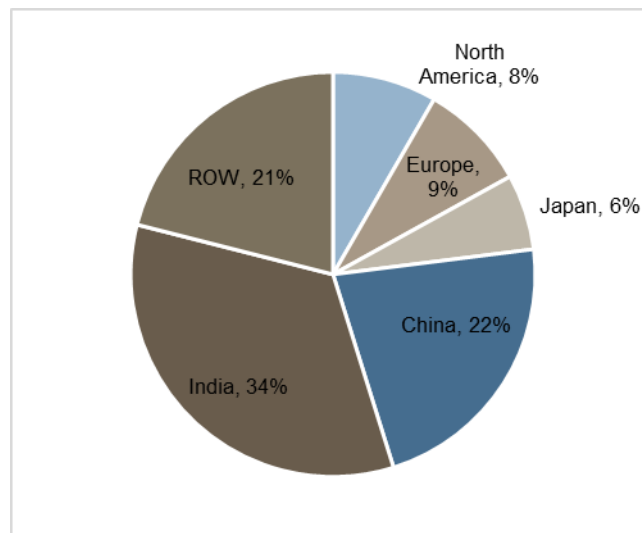

Source: Industry, CRISIL Research

*World Tractor Production (2022) – Geography-wise split*

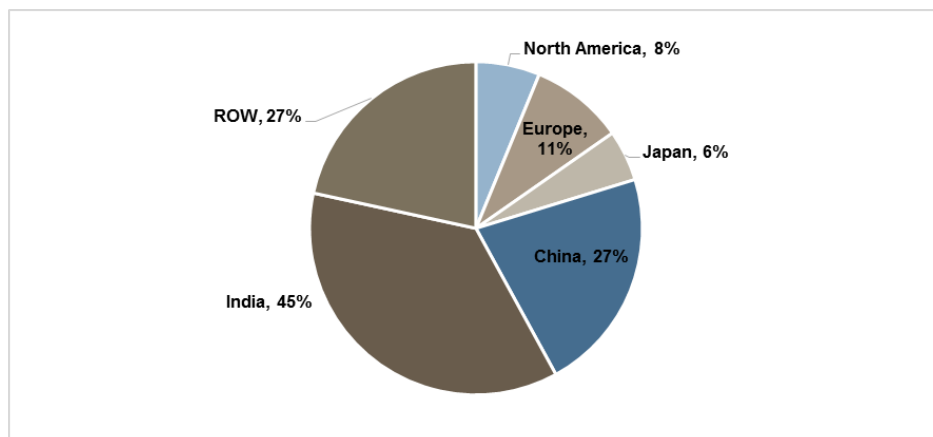

Source: Industry, CRISIL Research

Note: ROW includes tractor production in all the remaining geographies barring the five major geographies mentioned above

### Market Segmentation based on Horse Power (HP)

Of the world tractor demand estimated at 2.2 million units in 2017, approximately 82% is contributed by the <60 HP segment, which is driven by India, China, Japan and other developing economies. Whereas only 18% of the world tractor demand comes from >60 HP segment driven by the economies in Europe and North America. However, in the world market for 3-point linkages (3PL), which is estimated at US\$ 390-410 million in 2017, the contribution of >60 HP segment rises significantly on the back of higher price of 3PL in higher HP tractors. Approximately 51% of the demand comes from <60 HP segment, with the remaining 49% arising from >60 HP segment.

The structure of 3PL industry is fragmented in few geographies, whereas organized in other geographies 3PL manufacturers are generally private players. Therefore, it is difficult in mapping the industry players and evaluate competitive benchmarking.

- **North American 3PL market**

#### Outlook for North American tractor market

During 2017-2022, tractor production in North America is expected to record a CAGR of 3.1% to reach 213,831 units in 2022. Expected growth in the tractor production due to consolidation of farms, technological innovation and labor shortage is estimated to increase the demand of 3PL. As a result, 3PL market in North America is expected to increase at a CAGR of 6.2% to US\$ 80 million in 2022.

- **Demand review for North American tractor market**

Between 2013-2017, tractor production in North America recorded a CAGR of 1.8% to 183,300 units in 2017. Tractor production in 2017 was dominated by less than 60 HP category. It accounted for approx. 62.1% of the 2017 total production. Further, over 60 HP tractors and 4WD tractors accounted for 35.6% and 2.3%, respectively of 2017 total production.

#### *North America Tractor Production Volumes ('000 units)*

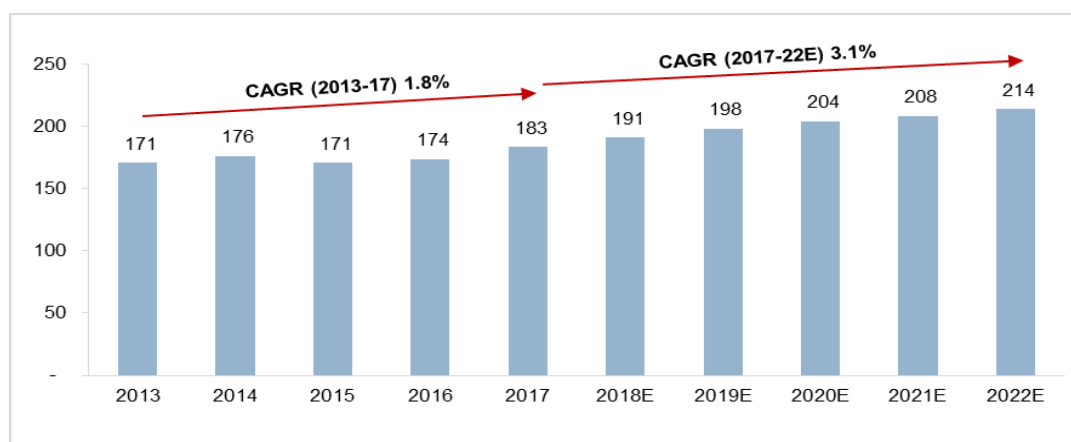

Source: Industry, CRISIL Research

Factors such as commodity prices, resolution of trade disputes, technological innovation, consolidation of farms, etc. will play an important role in shaping the market. During 2017-2022, North America's tractor production is expected to register a CAGR of 3.1% to reach 213,831 units in 2022.

#### **Demand drivers for tractors in North America**

North America is one of the leading farm equipment markets in value terms. It is considered a mature market. Compared to other regions, farmers in North America are wealthier and have adequate resources to invest in the agricultural machinery such as tractors. The US and Canada are key exporters of agricultural products in developing countries such as China, where food demand is relatively high due to high population. As a result, farms' income in

North America is relatively better than other parts of the globe.

Tractor demand in North America is mainly driven by farmers' ability to purchase tractors and is affected, both directly and indirectly, by a number of factors:

- Continued consolidation of Farms
- High level of farm mechanisation and labour shortage



- Focus on innovation and new technologies

*Continued consolidation of Farms*

The US is witnessing consolidation of farms. The number of farms declined from 2.21 million in 2007 to 2.05 million in 2017. During the same period, average US farm size has increased from 418 acres to 444 acres while share of small farms to total production is declining. Use of agricultural machinery is enabling the consolidated farms to improve efficiency and helping farmers to generate better profits and higher return on investment versus smaller farms

US – Number of Farms and Average Farm Size

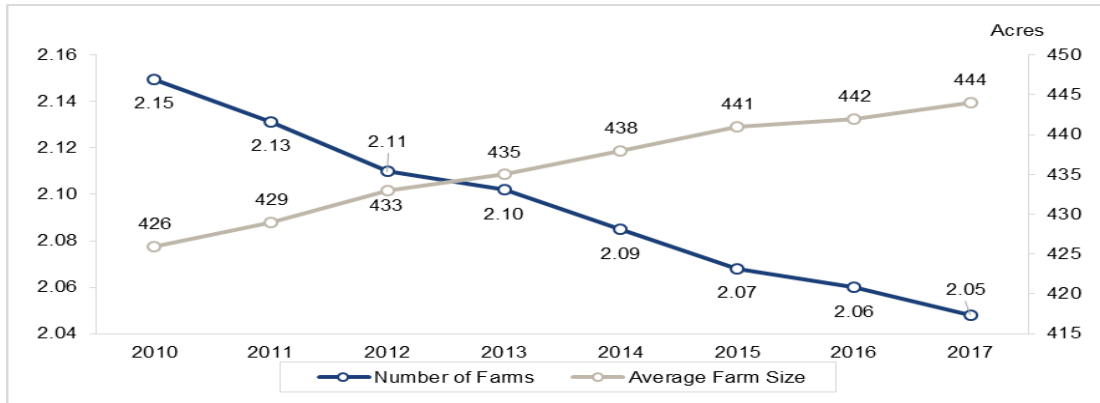

Source: US Department of Agriculture, CRISIL Research

*High level of farm mechanisation and labour shortage*

North America represents a high level of farm mechanisation with the US achieving more than 95% of the farm mechanisation. Farm mechanisation across North America is popular owing to the numerous benefits offered, including considerable savings in terms of time and resources, improved efficiency, and increased production. The shortage of North America’s farm labourers, mainly owing to changes in the US immigration policies, is expected to propel the use of mechanised farming techniques and equipment such as farm tractors. Additionally, precision farming has driven the need for mechanisation among various farm practices, thereby fuelling demand for farm tractors.

*Focus on innovation and new technologies*

The US government has made “adoption of innovative technology” a key focus. As part of this, the National Institute of Food and Agriculture (NIFA) launched a “Food and Agriculture Cyber informatics and Tools Initiative” in late 2016. It focuses on increasing collaboration between the government and private companies to capture the agriculture data and to support development in the sector. Data and analytics can help farmers hedge against potential losses and smooth out cash flow, which is always a concern in any agriculture operation.

*Outlook for North American 3PL market*

During 2013-2017, tractor production in North America increased at a CAGR of 1.8% to 183,300 units in 2017. The weighted average price of 3PL parts in 2017 was in the range of US\$ 310-330. 3PL Market in North America increased between 2013-2017 primarily due to growth in the number of tractors. 3PL Market in North America is expected to increase at a CAGR of 6.2% to US\$ 80 million 2022.

North America 3PL Market Value in (US\$ millions)

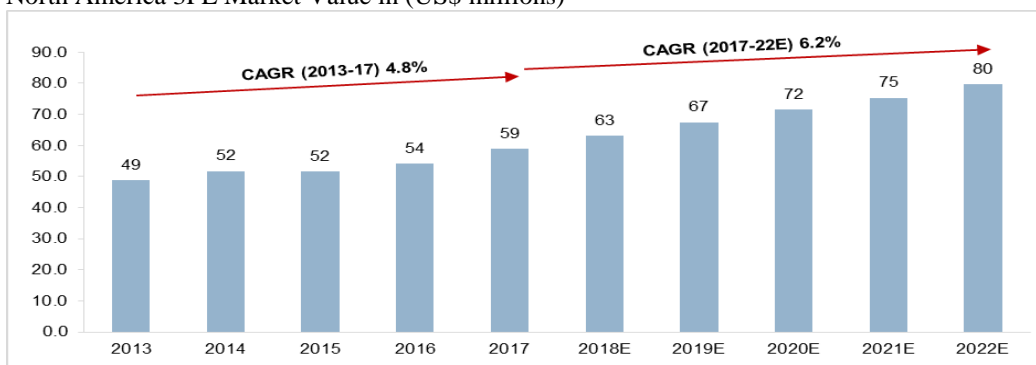

Source: Industry, CRISIL Research

- **European 3PL market**

Outlook for European tractor market

Factors such as shift towards larger farms, income of the farmers, technological innovation, etc. will play an important role in shaping up the market. During 2017-2022, tractor production in Europe is expected to register a CAGR of 5.5% to reach 248,251 units in 2022. Over 2013-2017, tractor production recorded annual decline of 3.4%.

Between 2017-2022, tractor production in Europe is expected to register a CAGR of 5.5% to reach 248,251 units in 2022. Expected growth in the tractor production due to shift towards larger farms, technological innovation, and increase in the income of farmers will drive the demand of 3PL. As a result, 3PL market in Europe is expected to increase at a CAGR of 8.7% to US\$ 161 million in 2022.

- **Demand review for European tractor market**

During 2013-2017, tractor production in Europe recorded a CAGR of 0.9%. Tractor production in 2017 is dominated by over 60 HP category. It accounted for about 94.7% of the total production in 2017. However, 4WD tractor production is not popular in Europe.

Europe Production Volumes of Tractors ('000 units)

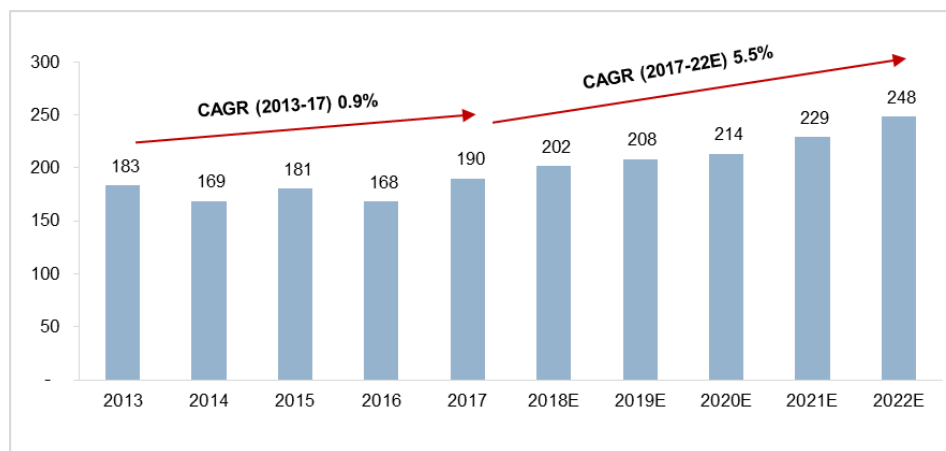

Source: Industry, CEMA, CRISIL Research

- **Demand drivers for tractors in Europe**

Europe is one of the major producers of agricultural products. According to the 2017 Agriculture, Forestry and Fishery statistics by Eurostat, the agricultural industry's total output (comprising the output values of crops and animals, agricultural services and the goods & services produced from inseparable non-agricultural secondary activities) was estimated at €405 billion in 2016. France is the largest agriculture producer with about 17.4% market share, followed by Italy (~13.2%), Germany (~13.1%), and Spain (~11.6%) in 2016.

Tractor demand in Europe is mainly driven by farmers' ability to purchase tractors and is affected, both directly and indirectly, by a number of factors:

- Continued shift towards large farms
- Technological innovation to develop high efficiency products

*Continued shift towards large farms*

Europe is witnessing a consolidation of farms with an increase in share of larger farms in the arable land. Key countries with ongoing national land consolidation programme include Poland, Germany, Czech Republic, Slovakia, Slovenia, Lithuania, Serbia, etc. Further, land consolidation has also been introduced in a number of countries including Estonia, Latvia, Hungary, Romania, Bulgaria, Croatia, etc., however these countries do not have a national land consolidation programme. In the region, largest farms are found in Czech Republic, Denmark, Great Britain, Germany, France, and Finland. Tractors accounts for over 42% of the investment by European farmers in new machinery and equipment. Farmers who have consolidated their farmlands or increased their farm area tend to buy new tractor with more horsepower. Moreover, farmers with larger holdings look for tractors with better technologies to increase the productivity and overall farm income.

### *Technological innovation to develop high efficiency products*

Tractor manufacturers are increasingly incorporating technologies such as data analytics, telematics, remote sensing, GPS, and mobile technology to make farming more precise and sophisticated. Technology is also helping farmers to reduce costs. For instance, auto steering enables farmers to reduce the overlaps by field equipment. Alternate fuel tractors are also gaining popularity in the market. Increase in prices of conventional fuels and rising environmental concerns is resulting in the adoption of alternate fuel tractors in the market. Demand of alternate fuel tractors is expected to further gain in the future. These benefits are stimulating the uptake of usage of technologies. This in turn is resulting in the increasing demand of tractors with latest technologies.

### Outlook for European 3PL market

Between 2013-2017, tractor production in Europe increased marginally at a CAGR of 0.9%. The weighted average price of 3PL parts in 2017 was in the range of US\$ 550-570. Underlying growth in the tractor volume and higher proportion of over 60 HP tractors resulted in the high share of Europe in the global 3PL market. 3PL market in Europe increased at a CAGR of 3.9% between 2013-2017 to US\$ 106 million in 2017. 3PL market in Europe is expected to increase at a CAGR of 8.7% to US\$ 161 million in 2022.

### *Europe 3PL Market Value in (US\$ millions)*

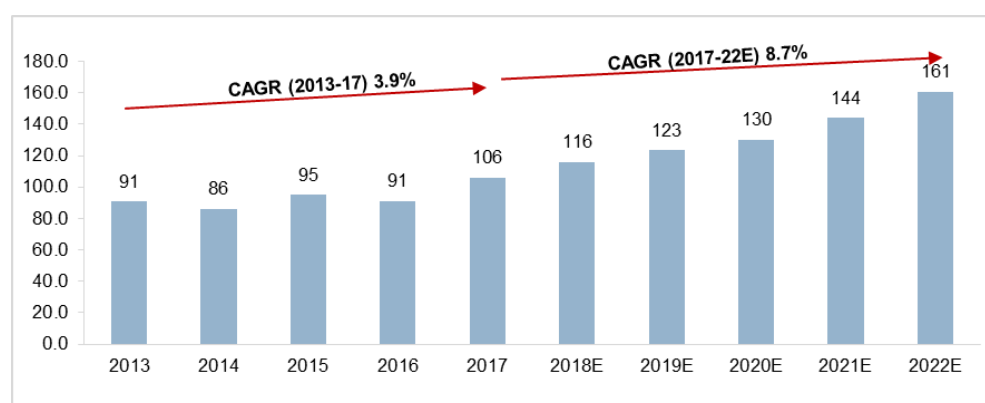

Source: Industry, CEMA, CRISIL Research

- **Japanese 3PL market**

### Outlook for Japanese tractor market

Between 2017-2022, tractor production in Japan is expected to register a marginal annual growth of 0.3% to 135,276 units in 2022. The growth in Japan will be slower compared to the US and Europe. However, factors such as labor shortage, aging population, and technological innovation will impact the tractor market. During the same period, 3PL market in Japan is expected to increase at a CAGR of 3.4% to US\$ 31 million in 2022.

- **Demand review for Japanese tractor market**

### *Japan Production Volumes of Tractor ('000 units)*

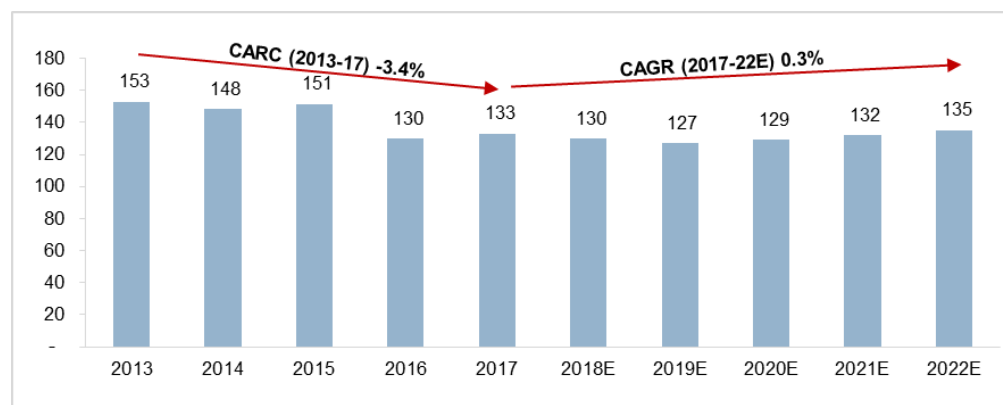

Note: CARC: Compounded Annual Rate of Change

Source: Japan Agricultural Machinery Manufacturers Association (JAMMA), Industry, CRISIL Research

Factors such as technological innovation, driverless tractors, etc. will play an important role in shaping up the market. However, during 2017-2022, Japan's tractor production is expected to register a marginal CAGR of 0.3% to reach 135,276 units in 2022.

- ***Demand drivers for tractors in Japan***

Japan's agricultural sector is relatively small and slowly contracting. According to the CIA World Factbook, agriculture accounted for about 1.0% of Japan's GDP in 2017, and employed 2.9% of the Japanese labour force. According to published World Bank data, arable land (as a percentage of total land) in Japan was 11.5% in 2015, lower than the global average of 14.5%. Farmers typically use terrace system to farm in small areas. This system has helped Japan to achieve world-leading yield per hectare.

Tractor demand in Japan is mainly driven by farmers' ability to purchase tractors and is affected, both directly and indirectly, by a number of factors:

- Aging population and labour shortage
- Focus on innovation and adoption of new technologies

*Aging population and labour shortage*

The Japanese population is getting older. The average age of farmers in Japan is nearly 66.6 years in 2017. According to Japan's National Institute of Population and Social Security Research, 29.2% of the population will be 65 years of age or older by 2020. The labour shortage in agriculture sector is worsening with each passing year. According to Japan's farm ministry, the number of labourers working on the nation's farms declined by about 50% over the last decade – dropping from 3.1 million in 2007 to 1.8 million in 2017 – and is expected to decline further. Aging population and labour shortage in the country is likely to push the farmers to invest in the agriculture equipment thereby boosting the tractor demand.

*Focus on innovation and adoption of new technologies*

Tractor companies are also developing new products such as fully-autonomous tractors. Companies are collaborating with research universities to develop self-driving robots. In June 2018, Yanmar launched autonomous tractors that are equipped with Information and Communications Technology (ICT) – which utilises precision positioning data and robot technology. The tractors are designed to enhance farm management efficiency, while realising significant labour savings. In 2017, Kubota began trial sale of its self-driving robot tractors that plough the land using GPS data. These innovations and technological developments are expected to result in purchase of new tractors by the farmers, thereby driving market growth.

*Outlook for Japanese 3PL market*

Between 2013-2017, tractor production recorded an annual decline of 3.4%. The weighted average price of 3PL parts in 2017 was in the range of US\$ 190-210. Underlying decline in the tractor volume and lower proportion of over 60 HP tractors resulted in the low share of Japan in global 3PL market. The market in Japan declined at an annual rate of 0.5% over 2013-2017 to US\$ 26 million in 2017. During the period 2017-2022, 3PL market in Japan is expected to increase at a CAGR of 3.4% to US\$ 31 million in 2022.

Japan 3PL Market Value in (US\$ millions)

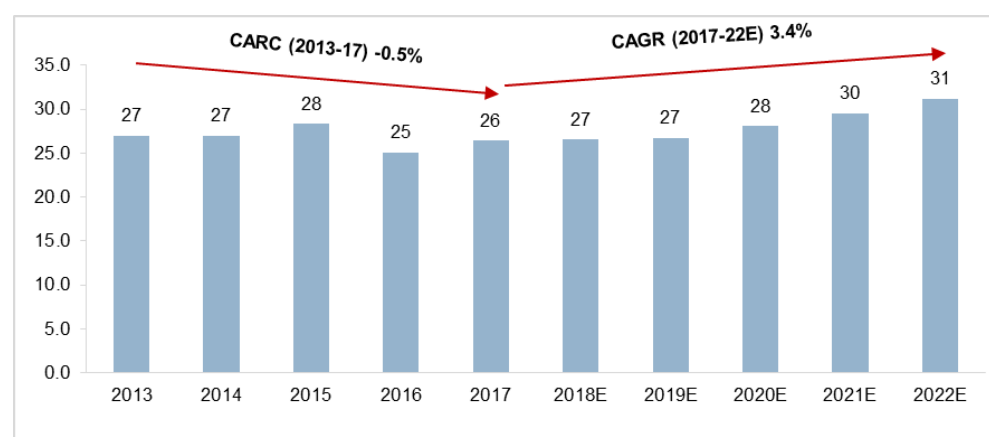

Note: CARC: Compounded Annual Rate of Change

Source: Japan Agricultural Machinery Manufacturers Association (JAMMA), Industry, CRISIL Research

## Indian 3PL market

### Outlook for Indian tractor market

More than half of India's work force is still reliant on the agricultural sector for employment. Furthermore, there has been continuous fragmentation in land holdings and average size of land holdings has declined from 1.33 hectares in 2000-2001 to 1.16 hectares in 2010-2011.

Tractors were predominantly used in land preparation and haulage. Tractor applications are now extending to other farming activities such as cultivation, seeding, inter-cultivation, weeding, and spraying. Increased multi-cropping and commercial usage of tractors is propelling tractor demand. Thus, there is potential not only to improve crop productivity but also to increase farm mechanisation in the country.

Production volume of tractors rose at CAGR of 2% between 2013 and 2017, on the back of a downfall in the industry for two consecutive years. However, a strong growth rate posted by the industry over past two years (2016 and 2017) and a healthy growth outlook over the medium term has encouraged players to expand tractor capacities.

Significant tractor capacities (about 100,000 units) are expected to be commissioned in coming few years. This is in addition to the 202,000 units estimated to have come on-stream in 2016 and 2017.

Tractor production is projected to grow 13-15% in 2018, with normal monsoon expected to result in healthy growth for the kharif cropping cycle and improved farmer sentiment. Government's increasing focus on rural activities has significantly boosted agricultural and commercial demand for tractors. Further, minimum support prices for kharif cropping cycle has increased 25-30% on an average, improving farm income. Credit availability continues to be stable with NBFCs strengthening their focus on tractor financing. Between 2017-2022, tractor production in India is expected to increase at a CAGR of 4.0%.

### **Demand review for Indian tractor market**

In 2017, tractor production grew robustly at 15%, owing to two consecutive years of near-normal monsoon, government support in various states, subsidy sales and announcements of farm loan waiver in certain states.

#### *India's tractor production volumes ('000 units)*

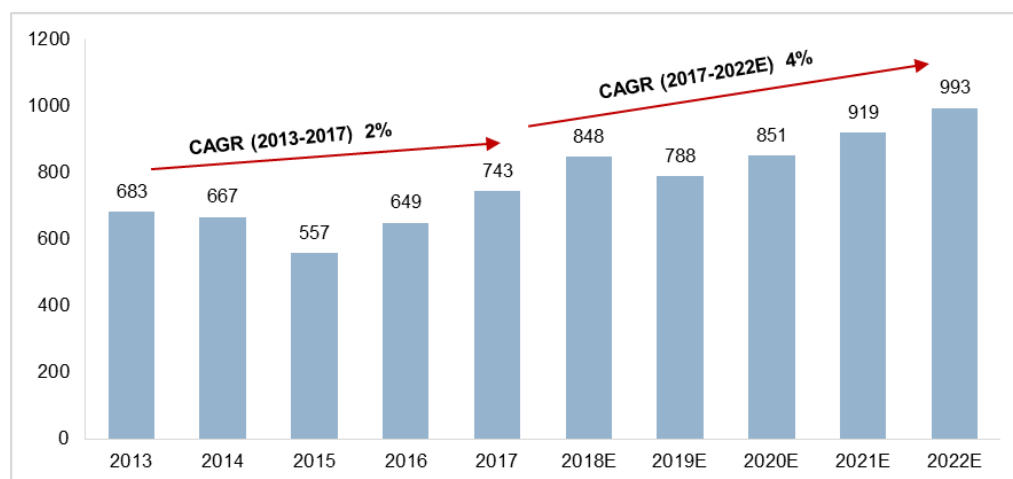

Source: TMA, Crisil Research

### **Demand drivers for tractors in India**

Comparatively adolescent by world standards, India's tractor market has expanded at a spectacular pace in last few years. For a long time since Independence, the market was dominated by mid-sized tractors with engine capacity of 30-40 horse power (HP). But it has diversified in recent years, which is evident in the rising demand for both bigger (over 50 HP) and smaller (below 20 HP) tractors.

Tractor demand is mainly driven by farmers' ability to purchase tractors and is affected, both directly and indirectly, by a number of factors:

- Irrigation intensity and monsoons
- Small landholding limits mechanisation advantages

- Availability of credit on the rise
- Minimum support prices of food grains
- Cropping pattern
- Replacement demand

#### *Irrigation intensity and monsoons*

Irrigation plays a vital role in determining demand for tractors. A farmer will prefer to invest in costlier assets such as tractors only when he is assured of receiving essentials for farming such as water supply. The irrigation spends which increased significantly in last two decades have aided both irrigation and cropping intensity, thus leading to higher and stable farm incomes. Irrigation intensity is expected to improve further over the medium term, supporting tractor sales. Irrigation intensity in India has improved 5% to around 45% in last one decade. However, India continues to have lower irrigation intensity than China (52% irrigation intensity). Hence, dependence on monsoon for farming is relatively higher. Continuous deficient monsoons also impact reservoir levels, which, in turn, affect irrigation intensity

#### *Small landholding limits mechanisation advantages*

Average land holding size in India is very low at 1.16 hectares (ha) against world average of 3.7 ha, with about 65% of farmers being marginal farmers (holding less than 1 ha). This has deterred tractor demand. Moreover, average landholding size has been declining due to socio-economic factors such as break-up of joint families and division of ancestral land. Declining landholding size has both positive and negative impact on tractor demand. With division of larger landholdings into smaller ones, number of tractors required is expected to rise. However, a tractor would become uneconomical for small farmers due to reduction in farm size. But with proportion of landholdings below 2 ha being very high, consolidation of landholdings will drive demand in the long run.

#### *Availability of credit on the rise*

In India, around 75% of tractors purchased are on credit, so its availability becomes a key demand driver for the industry. Any major change in financing norms directly impacts demand for tractors. Agricultural credit usage in farm mechanisation has been growing steadily over the years, enhancing farmers' ability to buy tractors. Public sector banks and non-banking financial companies (NBFC) are major financiers. Over the last decade, cumulative share of public sector banks (PSB), co-operative banks, and regional rural banks has come down from about 75% to 15-20%, with NBFCs now accounting for about 50-55% of the market.

#### *Minimum support prices of food grains*

Government fixes procurement prices of food grains. These prices affect market prices, as they are used as a base for their calculation. Change in procurement prices directly affects a farmer's income as it impacts his loan repayment capability. Government has consistently raised minimum support prices (MSP) of major crops such as wheat, rice, sugar cane and cotton, starting from fiscal 2007. MSPs have risen at CAGR of 10-15% from fiscal 2007 to 2014, vis-a-vis 1-5% growth during fiscals 2002 to 2007. This has reduced volatility in farm incomes, notwithstanding some fluctuations in agricultural production, arising from deviation in rainfall. However, since Fiscal 2015, hike in MSPs has been modest, compared with CAGR of 10-15% in previous seasons.

#### *Cropping pattern*

Farmers are being encouraged and educated by state governments to improve farm productivity and increase their incomes, and to further improve farm productivity, farmers are practicing multiple cropping. Use of tractors helps a farmer to complete operations quickly, after which he can move on to the second crop. Multiple cropping boosts farm yield and thus farm incomes, and lifts demand for tractors.

#### *Replacement demand*

Lifespan of a tractor is estimated at 10-15 years, though actual usage could vary, depending on soil and cropping conditions. Usually, the farmer who is replacing a tractor would want to upgrade to a higher-powered tractor. Hence, given increasing income levels and existing numbers of lower-powered tractors, replacement demand in states such as Punjab and Uttar Pradesh would be high for higher-powered tractors.

#### *Outlook for Indian 3PL market*

Growth of tractor sales has helped to increase demand for 3PL. During 2013-2017, the 3PL market value grew at CAGR of 5%. Average price for 3PL parts in the market was estimated at US\$ 80-82.

The 3PL industry has surged in past two years on the back of a strong growth in overall tractor production and increase in average price of 3PL parts in the market.

*India's 3PL market value in millions US\$*

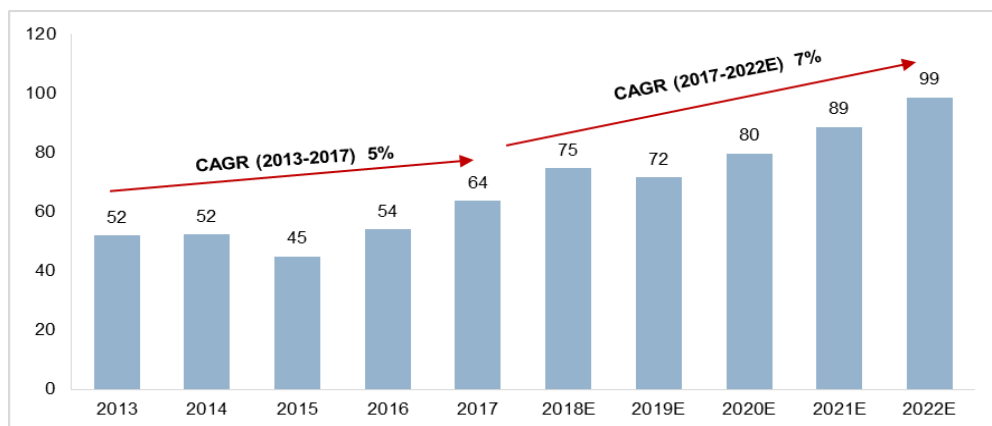

Source: Crisil Research

Between 2017 and 2022, with increasing mechanisation in India’s agriculture sector, supply of tractors is expected to increase at CAGR of around 4%, coupled with rise in average price of 3PL parts in the market, due to hike in raw material cost. This will lift demand for 3PL at CAGR of around 7%.

**PMP Market**

Precision Machined Part (PMP) is a group of products that are components requiring stringent material and manufacturing specifications and controls. These include among others, precision machined components eg. pins, bushes used in articulated joints across the construction, forestry and mining equipment. Depending on the usage, pins and bushes are made up of different grades of alloy. Raw materials such as bronze, steel, copper, etc. are used. However, steel is the main raw material used. They are manufactured using machining, forging, etc. These products are generally outsourced for manufacturing.

The world market for PMP for articulated joints is estimated to be US\$ 409 million in 2017. Global production value for PMP for articulated joints is expected to grow at CAGR of 5-7% during 2017-2022, registering an increase in the growth rate compared to 2013-2017 period which was a CAGR of 3%. This expansion will be fuelled primarily by growth in North America and India, where construction spending, especially on infrastructure projects, continues to increase. China, being the largest market globally, contributes around 31% to the total market share and is expected to grow at a CAGR of 3-5% from 2017-2022. India, contributing around 9%, is expected to grow at a CAGR of 17-19% from 2017-2022 due to higher investments towards infrastructure activities and expansion plans by various construction equipment manufacturers. Japan and Europe are the second and third largest consumers of PMP for articulated joints parts respectively, contributing approximately 36% of the world market.

The current market sizing for PMP includes only pins and bushes used in articulated joints. However, different vendors offer different levels of value addition and provide ancillary services to the OEMs based on their requirement, which could vary across geographies, model types and equipment categories. When we include the same (which would include child parts and services apart from manufacturing pins and bushes), the market size in 2017 would be pushed up to US\$ 475-516 million differing in the range of 5-40% across geographies depending on the value addition done.

**Precision Machine Parts for Articulated Joints - Market Value (US\$ Million)**

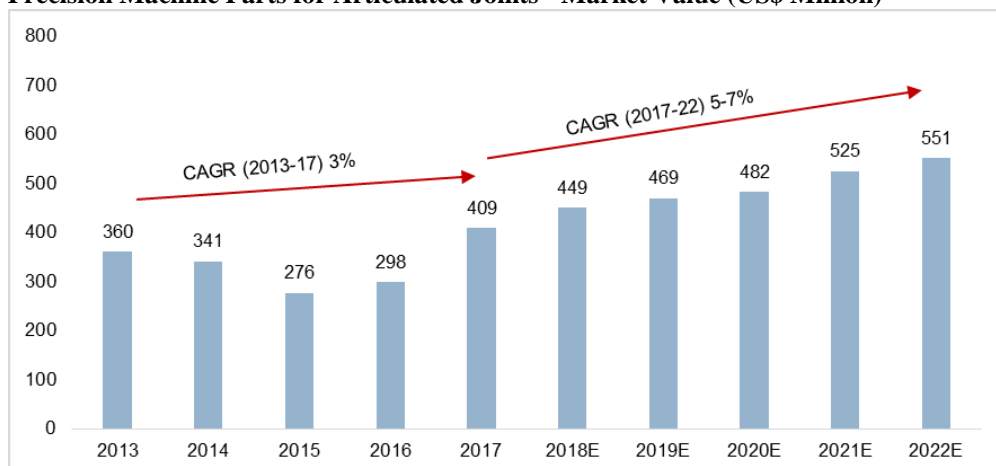

Note: E-Estimates

Source: Crisil Research

Note: The current market sizing for PMP includes only pins and bushes used in articulated joints. However, different vendors offer different levels of value addition and provide ancillary services to the OEMs based on their requirement, which could vary across geographies, model types and equipment categories. When we include the same (which would include child parts and services apart from manufacturing pins and bushes), the market size in 2017 would be pushed up to US\$ 475-516 million differing in the range of 5-40% across the geographies depending on the value addition done.

The rest of the world contribute 11% of the total PMP for the articulated joints market. From 2013-2017, it has grown by 2% CAGR and is expected to grow at 4-6% from 2017-2022.

**Worldwide PMP for Articulated Joints Market (US\$ 360 mn) in 2013**

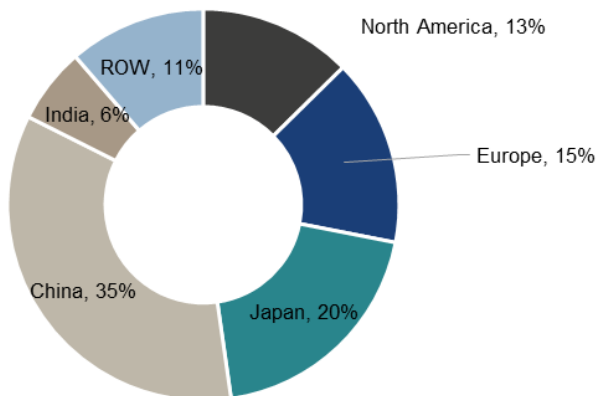

Source: CRISIL Research

**Worldwide PMP for Articulated Joints Market (US\$ 409 mn) in 2017**

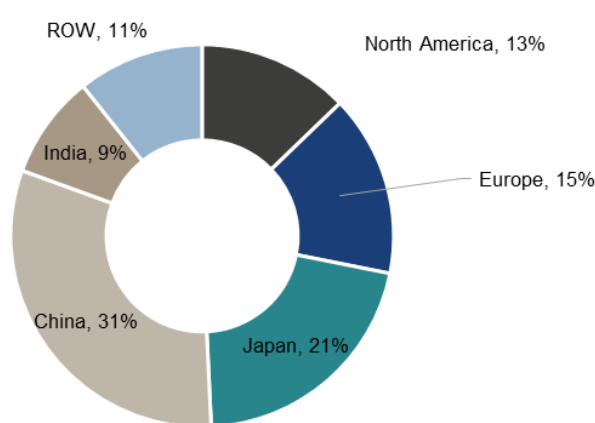

Source: CRISIL Research

**Worldwide PMP for Articulated Joints Market (US\$ 551 mn) in 2022**

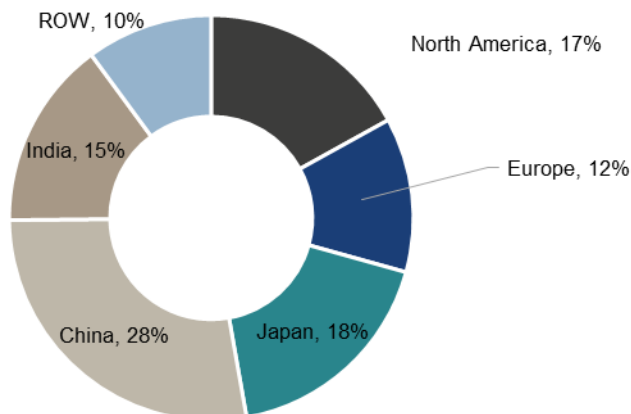

Source: CRISIL Research

**Compound Annual Growth Rates – PMP**

Compounded Annual Growth Rates (%)	North America	Europe	Japan	China	India	ROW	Total
Review (2013-17)	3%	3%	5%	1%	12%	2%	3%
Outlook (2017-22)	12%	2%	3%	4%	18%	5%	6%

China and Japan occupies almost half of the PMP market

Global market of the above defined precision machined parts (PMP) for articulated joints was an estimated US\$ 409 million in 2017, with 80% and above of the demand from four key geographies China, Japan, Europe and North America. The demand for such products is expected to grow at a healthy 5-7% CAGR in the 5-year period 2017-2022, powered by strong volume growth in construction equipment production in key markets such as North America. The current market sizing for PMP includes only pins and bushes used in articulated joints. However, vendors also offer value additions and ancillary services to OEMs based on customer standards and preferences. When we include the same, the market size in 2017 would be



pushed up to US\$ 475-516 million differing in the range of 5-40% across the geographies depending on the value addition done.

PMP production (value) during 2017-2022 is expected to grow at twice the rate as seen during 2013-2017 period. Growth is expected to be seen mainly from North America (11-13% CAGR between 2017-2022), and India (17-19% CAGR between 2017-2022). Higher volume growth of construction equipment in North America, due to expected higher construction spending, which will be driven by growth across the residential, non-residential and non-building construction segments. In India, due to higher push to infrastructure segment in next 5 years, higher demand for construction equipment is expected. Major OEMs are developing technically intensive products, processes and applications which has led to higher mechanization of the construction equipment. This is expected to aid the growth of PMP industry.

In 2017, China occupies the major share (31%), however it has seen slowest growth (1%) amongst other geographies in last 5 years (2013-2017). The slowdown in overall economic activity in most key global economies during the 2014 to 2016 had impacted construction equipment industry. At a global level, construction equipment industry saw a growth of marginal 1% from 2013 to 2017. After a decline from 2014 to 2016, the industry had peaked in 2017 for most of the geographies. This momentum is expected to continue for most of the geographies even in 2018.

*Construction equipment volume demand to remain stable in next five years*

Key driver for the construction equipment industry is the investment in infrastructure projects. From 2017-2022, growth is expected to be driven by North America and India due to higher expected investment in infrastructure projects. However, stable growth in major geographies such as China and Japan and expected marginal de-growth in Europe is expected to limit the growth of construction equipment industry at 2-4% from 2017 to 2022.

**Worldwide Construction Equipment Production Market (890 thousand units) in 2013**

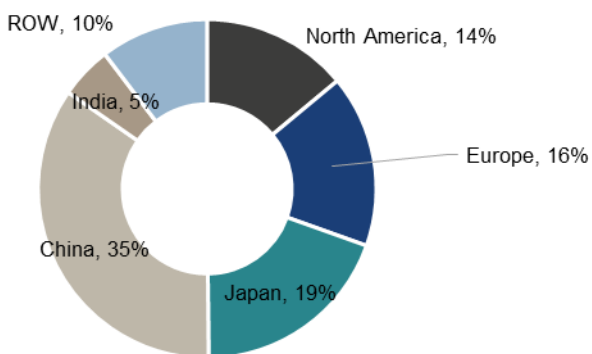

Source: CRISIL Research

**Worldwide Construction Equipment Production Market (922 thousand units) in 2017**

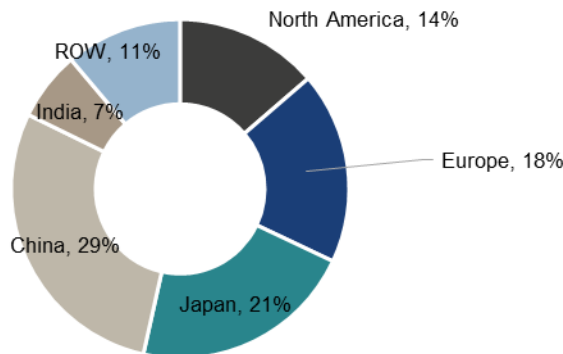

Source: CRISIL Research

**Worldwide Construction Equipment Production Market (1054 thousand units) in 2022P**

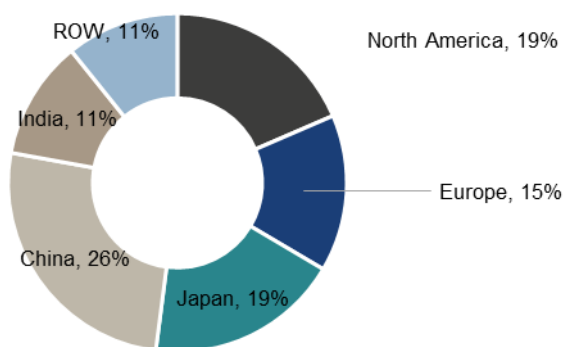

Source: CRISIL Research

**Compound Annual Growth Rates – Construction Equipment**

Compounded Annual Growth Rates (%)	North America	Europe	Japan	China	India	ROW	Total
Review (2013-17)	0%	4%	3%	-4%	8%	3%	1%
Outlook (2017-22)	9%	-1%	0%	1%	14%	2%	3%

In volume terms, China currently in 2017 occupies the highest proportion (29%) of the global construction equipment production. After declining by 4% from 2013-2017, we expect the volumes to grow marginally in the range of 0-2% from 2017-2022. A stable growth is expected due to higher investment in building highways, airports, etc. China's Belt and Road Initiative is expected to benefit the construction equipment market.

The European construction equipment industry grew modestly in 2016, and increased by 11% in 2017, with momentum growing during the year. The construction industry is in good shape in most markets. However, the growing threat to free trade and the risk of a global trade war pose a severe risk to the world economy. It is not clear yet if this will have an impact on the equipment market, and possibly result in changes in competitiveness between different regions. Hence, we expect the volume to remain in the range of (2)-0% from 2017 to 2022.

The structure of PMP industry is fragmented in few geographies, whereas organized in other geographies PMP manufactures are generally private players. Therefore, it is difficult in mapping the industry players and evaluate competitive benchmarking.

### North American PMP Market

#### Outlook for North American Construction Equipment market

Annual value of public construction in the US increased at a CAGR of 1.1% between 2013-2017. The low growth was primarily due to the decline in construction activities for healthcare, power, public supply, water supply, and sewage and waste disposal. Between 2013-2017, construction equipment production in North America recorded a marginal CAGR of 0.3% to 126,169 units in 2017. The share of mini excavators in total production increased from 6.7% in 2013 to 13.9% in 2017. During the same period, the share of skid steer loaders and backhoe loaders in total production declined.

Driven by economic recovery, US construction spending is expected to grow to 6.9% of GDP in 2021 from 6.5% of GDP in 2016. This will be driven by growth across the residential, non-residential and non-building construction segments. As a result, North America's construction equipment volume is expected to grow. Construction equipment production in North America is expected to grow at a CAGR of 9.1% between 2017-2022 to 194,767 units in 2022. Coupled with change in price of raw material and increasing mechanisation, we expect the construction equipment market to grow at a CAGR of 12.3% between 2017-2022.

#### North America Construction Equipment Production Volume ('000 Units)

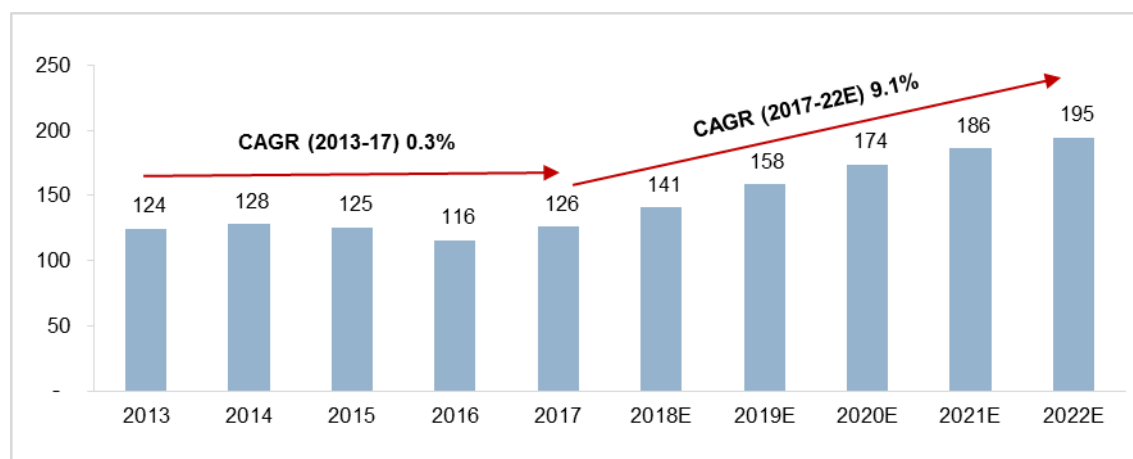

Source: Industry, CRISIL Research

#### North America Construction Equipment Production Value (\$ Million)

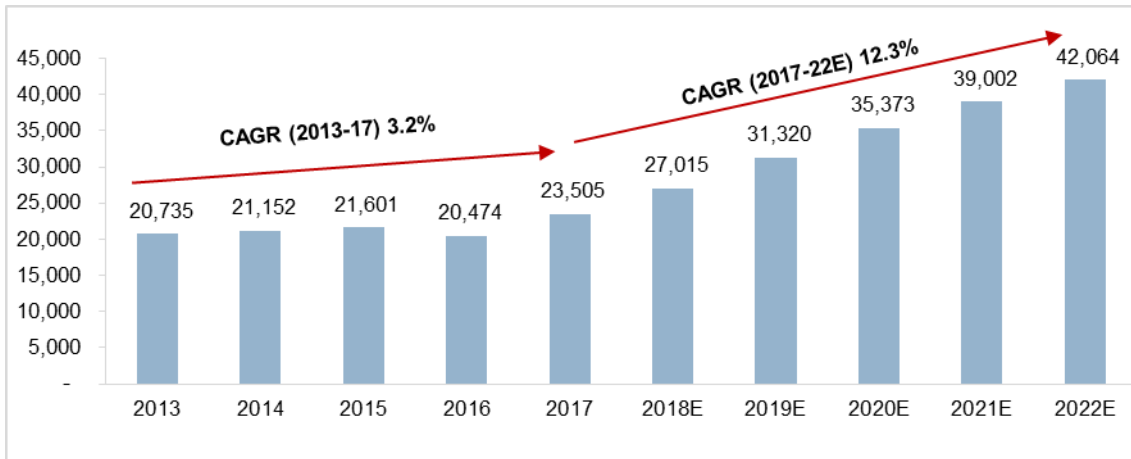

Source: Industry, CRISIL Research

### Outlook for North American PMP market

North America PMP for the articulated joints market is approximately US\$ 52 million in 2017, with major construction equipment manufactured being skid steer loader, crawler excavator, mini excavators, more than 80 HP wheeled loaders, etc. The market is expected to grow at a CAGR of 12.3% between 2017-2022 to US\$ 94 million in 2022. Growth will be driven by higher spending in construction activities by USA and Canada,

Structure of Unit Production by Product Category (% of Total)

Year	Skid Steer Loaders	Crawler Excavators	Mini Excavators	Wheeled Loaders > 80 HP	RTLs - Telescopic	Crawler Dozers	Others
2017	28.6%	15.7%	13.9%	13.0%	11.7%	5.6%	11.6%

Source: Industry, CRISIL Research

North America PMP Market Value (US\$ Million)

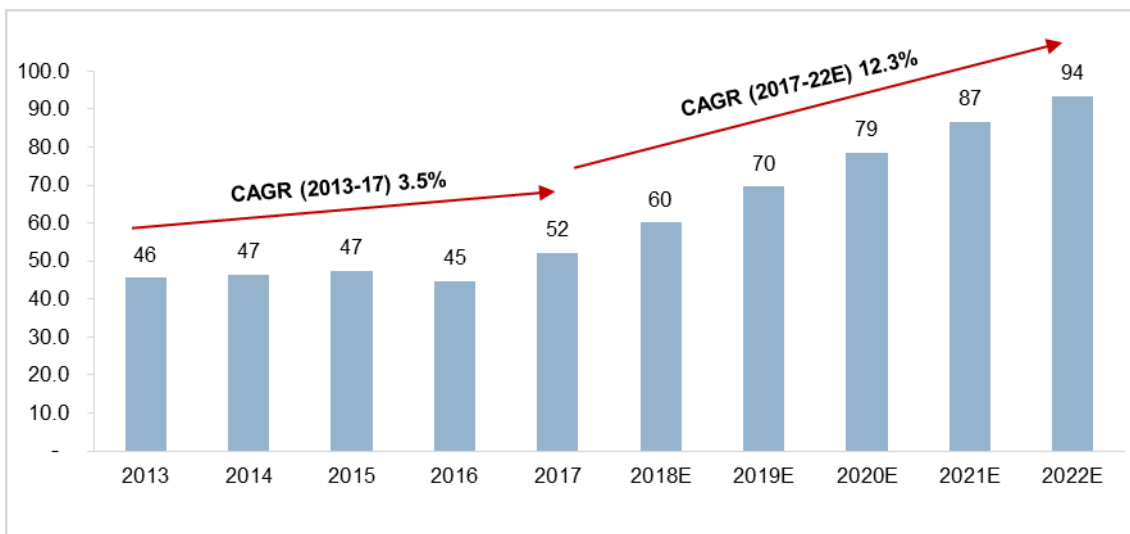

Source: Industry, CRISIL Research

*NOTE: The current market sizing for PMP includes only pins and bushes used in articulated joints. However, different vendors offer different levels of value addition and provide ancillary services to the OEMs based on their requirement, which could vary across model types and equipment categories. When we include the same (which would include child parts and services apart from manufacturing pins and bushes), the market size in 2017 would be pushed up to 15-25% i.e. US\$ 60-65 million depending on the value addition.*

### **European PMP Market**

#### Outlook for European Construction Equipment market

After growing modestly in 2016, the European construction equipment industry saw a boom in 2017, with momentum growing during the year. The construction industry is in good shape in most markets. However, the growing threat to free

trade and the risk of a global trade war pose a severe risk to the world economy. It is not clear yet if this will have an impact on the equipment market, and possibly result in changes in competitiveness between different regions.

Construction equipment production in Europe recorded a CAGR of 3.6% between 2013-2017 to 168,760 units. The share of mini excavators in total production increased from 16.1% in 2013 to 25.0% in 2017. During the same period, the share of backhoe loaders and crawler excavators in total production declined.

Europe Construction Equipment Production Volume ('000 Units)

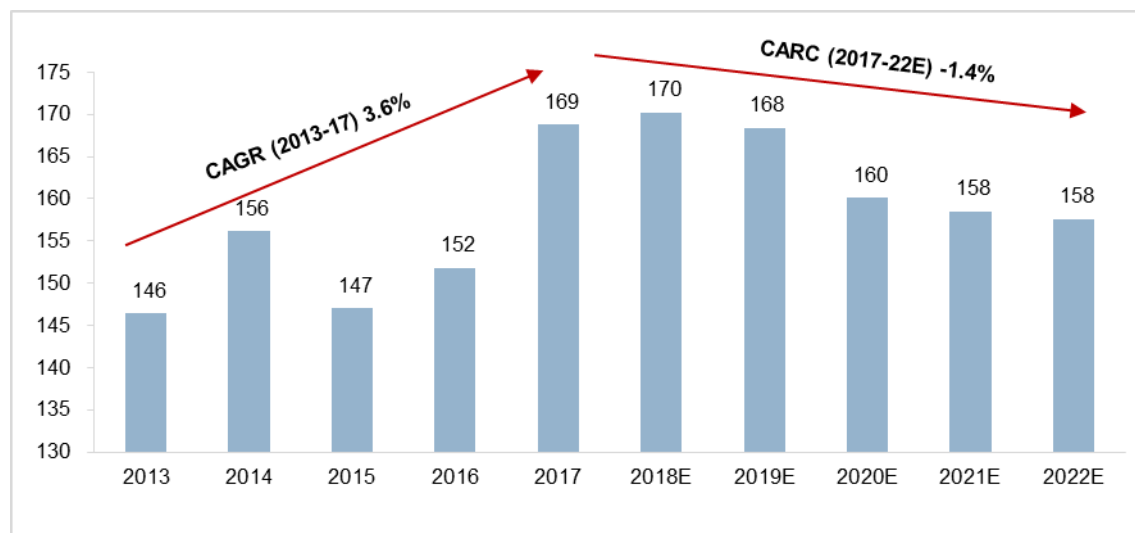

Note: CARC: Compound Annual Rate of Change

Source: Industry, CRISIL Research

Europe Construction Equipment Production Value (\$ Million)

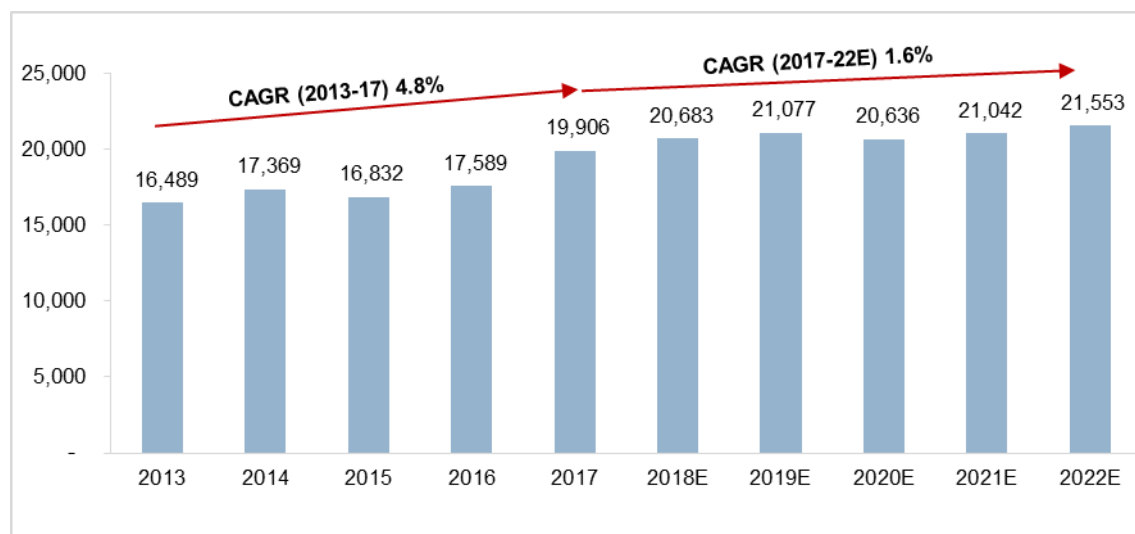

Source: Industry, CRISIL Research

### Outlook for European PMP market

Europe PMP for the articulated joints market is approximately US\$ 63 million in 2017, with major construction equipment manufactured being RTLs - telescopic, mini excavators, wheeled and backhoe loaders, etc. The market is expected to grow at a CAGR of 1.6% between 2017-2022 to US\$ 68 million in 2022. This marginal growth in next five years is due to muted growth of construction equipment industry after the expected peak in 2018 on account of growing threat of free trade which possibly result in changes in competitiveness between different regions.

Structure of Unit Production by Product Category (% of Total)

Year	RTLs - Telescopic	Mini Excavators	Wheeled Loaders < 80 HP	Backhoe Loaders	Wheeled Loaders > 80 HP	Crawler Excavators	Others
2017	26.4%	14.4%	12.8%	11.9%	10.7%	5.2%	18.5%

Source: Industry, CRISIL Research

Europe PMP Market Value (US\$ Million)

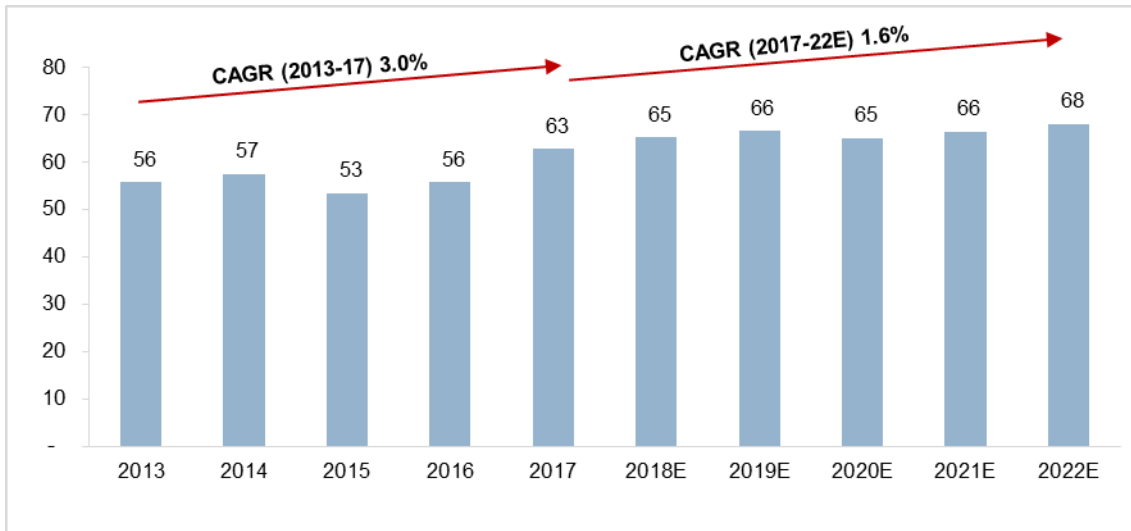

Source: Industry, CRISIL Research

NOTE: The current market sizing for PMP includes only pins and bushes used in articulated joints. However, different vendors offer different levels of value addition and provide ancillary services to the OEMs based on their requirement, which could vary across model types and equipment categories. When we include the same (which would include child parts and services apart from manufacturing pins and bushes), the market size in 2017 would be pushed up to 20-30% i.e. US\$ 75-82 million depending on the value addition.

**Japanese PMP Market**

Outlook for Japanese Construction Equipment market

Between 2013-2017, the construction equipment production in Japan recorded a CAGR of 3.4% to 197,840 units in 2017. The share of mini excavators in the total production increased from 42.4% in 2013 to more than 50% in 2017. At the same time, the share of crawler excavator declined from 42.4% in 2013 to 38.9% in 2017. Also, the share of crawler dozers, and wheel loaders in the total production declined over 2013-2017.

Between 2017-2022, construction equipment production is expected to decline at an annual rate of 0.3%, however, the market is expected to touch a level of 209,612 units in 2021. Key factors that will impact the market are infrastructure requirement for 2020 Olympics as well as investments by the government to develop road, rail, and airport.

Japan Construction Equipment Production Volume ('000 Units)

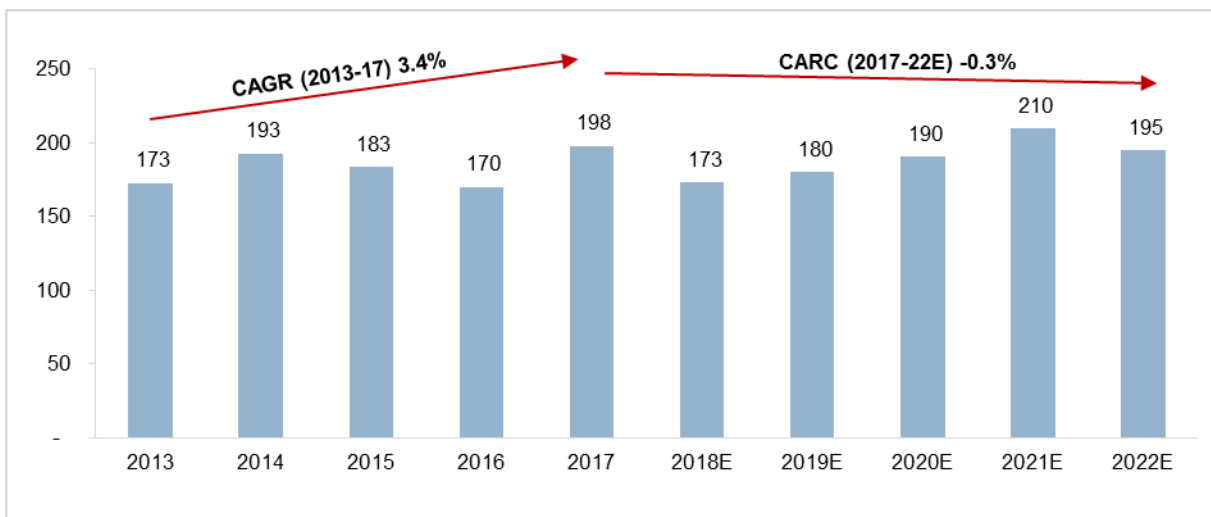

Note: CARC: Compound Annual Rate of Change

Source: Industry, CRISIL Research

Japan Construction Equipment Production Value (US\$ Millions)

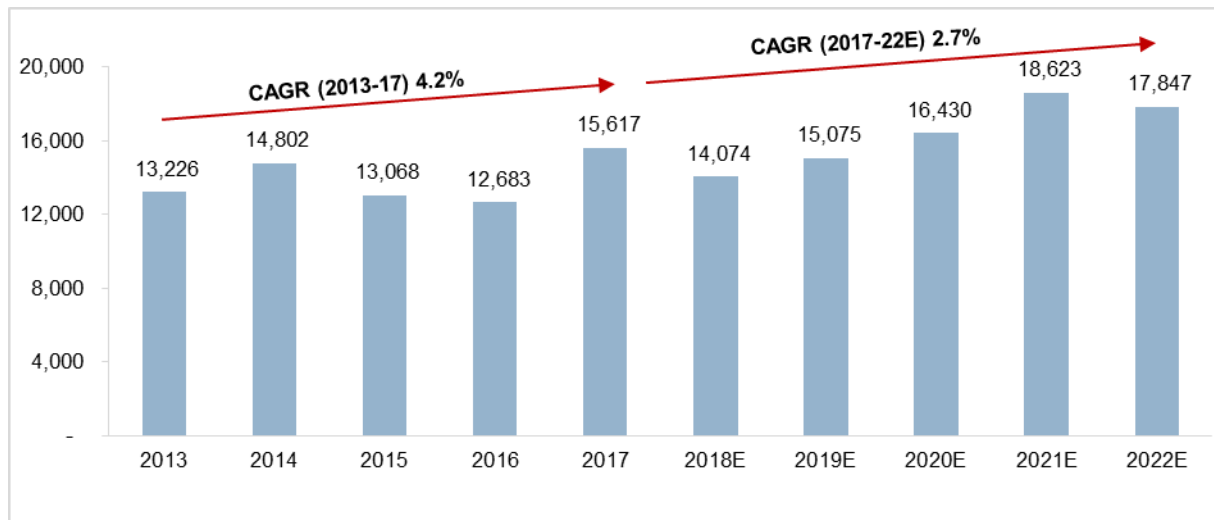

Source: Industry, CRISIL Research

Outlook for Japanese PMP market

Japan PMP for the articulated joints market is approximately US\$ 86 million in 2017, with major construction equipment manufactured being skid steer loaders, excavators (mini and crawler), wheeled loaders, etc. The market is expected to grow at a CAGR of 2.7% between 2017-2022 to US\$ 99 million in 2022. PMP growth will be impacted by demand for construction equipment due to infrastructure requirement for 2020 Olympics as well as investments by the government to develop road, rail, and airport.

Structure of Unit Production by Product Category (% of Total)

Year	Skid Steer Loaders	Crawler Excavators	Mini Excavators	Wheeled Loaders > 80 HP	Others
2017	50.5%	38.9%	3.7%	2.8%	4.1%

Source: Industry, CRISIL Research

Japan PMP Market Value (US\$ Million)

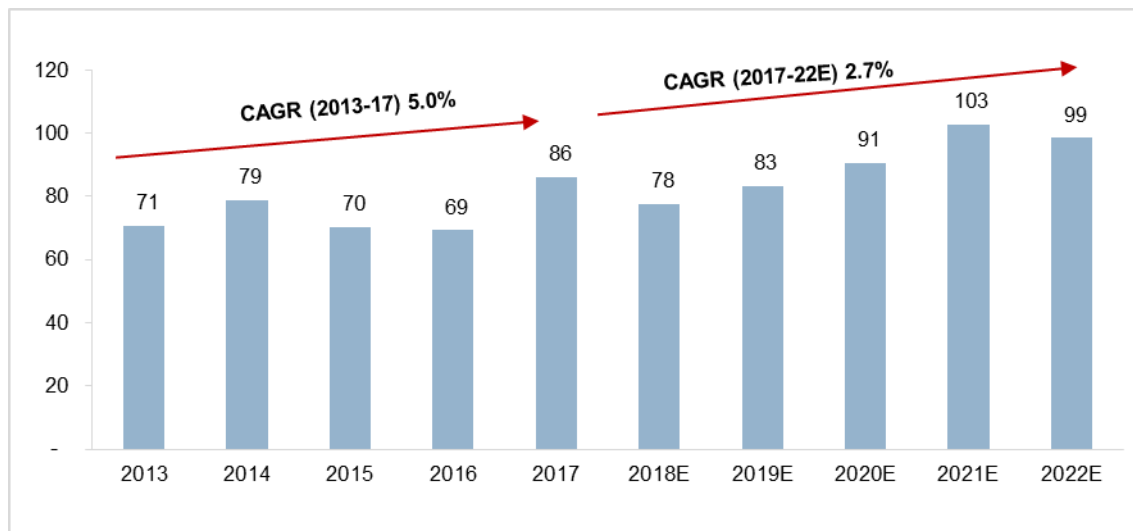

Source: Industry, CRISIL Research

NOTE: The current market sizing for PMP includes only pins and bushes used in articulated joints. However, different vendors offer different levels of value addition and provide ancillary services to the OEMs based on their requirement, which could vary across model types and equipment categories. When we include the same (which would include child parts and services apart from manufacturing pins and bushes), the market size in 2017 would be pushed up to 20-30% i.e. US\$ 103-112 million depending on the value addition.

**Indian PMP Market**

Outlook for Indian Construction Equipment market

The momentum seen from 2016 till date is expected to continue until 2022. We expect the Indian construction industry to grow at a compounded annual growth rate (CAGR) of 15% (in volume terms) between calendars 2017 and 2022, i.e., almost twice the growth rate between calendars 2013 and 2017.

Higher mining activity is expected to boost the demand for earthmoving and mining equipment. The government is taking various initiatives to increase domestic coal production. In February 2018, commercial mining was opened to private players. We expect investments in mining to grow at a faster pace and give a significant fillip to demand for earthmoving and mining equipment.

**Indian construction equipment market, production volume ('000 units)**

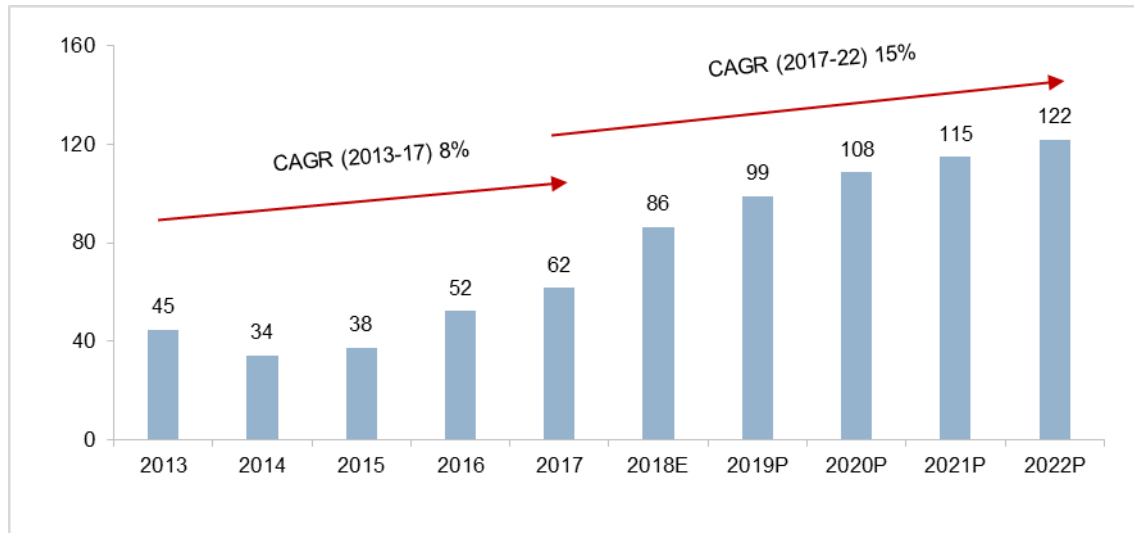

Source: ICEMA, Industry, CRISIL Research

**Indian construction equipment production value (US\$ million)**

In value terms, construction equipment market is expected to grow at 16% CAGR vis-à-vis 9%.

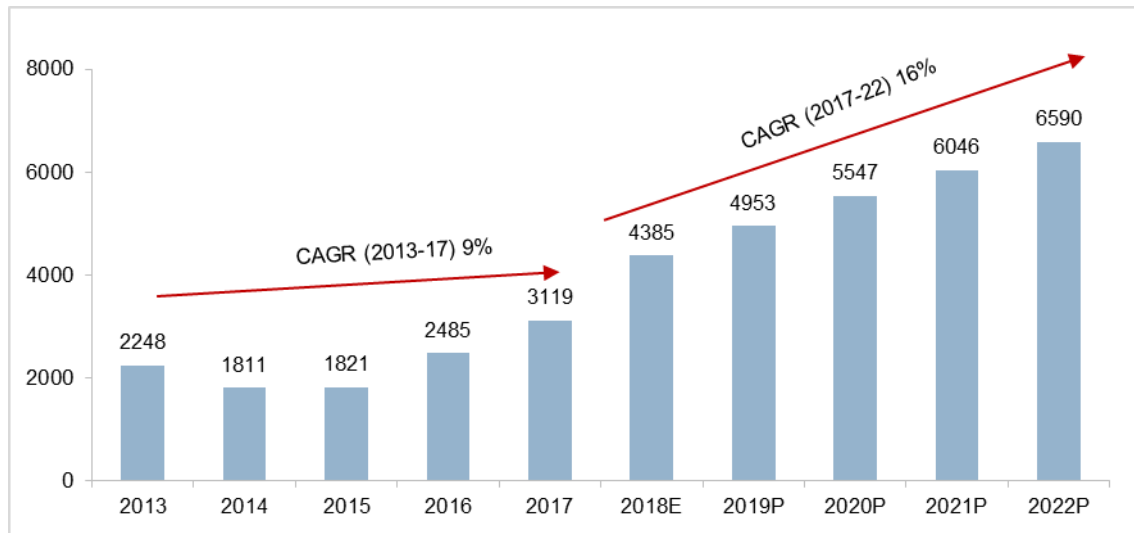

Source: Industry, CRISIL Research

Outlook for Indian PMP market

India’s PMP market for pins and bushes used in articulated joints was US\$ 36 million in 2017, with major construction equipment manufactured being backhoe loader and crawler excavator. From 2013 to 2017, the PMP market has grown by 12% CAGR on account of revival in equipment growth post mid-2015 mainly due to the push by the Government towards infrastructure and other construction related activities.

We expect the PMP market in India to grow by 18.2% CAGR between fiscals 2017 and 2022 to US\$ 83 million, surpassing growth in the previous 4 years, owing to higher expected growth in the construction equipment market. Expansion plan by various Original Equipment Manufacturers (OEMs) and higher push by the Government for “Make In India” products is expected to incentivize construction equipment production in India.

**Structure of unit production by product category (% of total)**

Year	Backhoe loader	Excavator	Wheeled loader	Rigid dump trucks	Skid steer loader
2017	57.9%	34.3%	3.0%	4.6%	0.2%

Source: Industry, CRISIL Research

**India PMP market value in (US\$ million)**

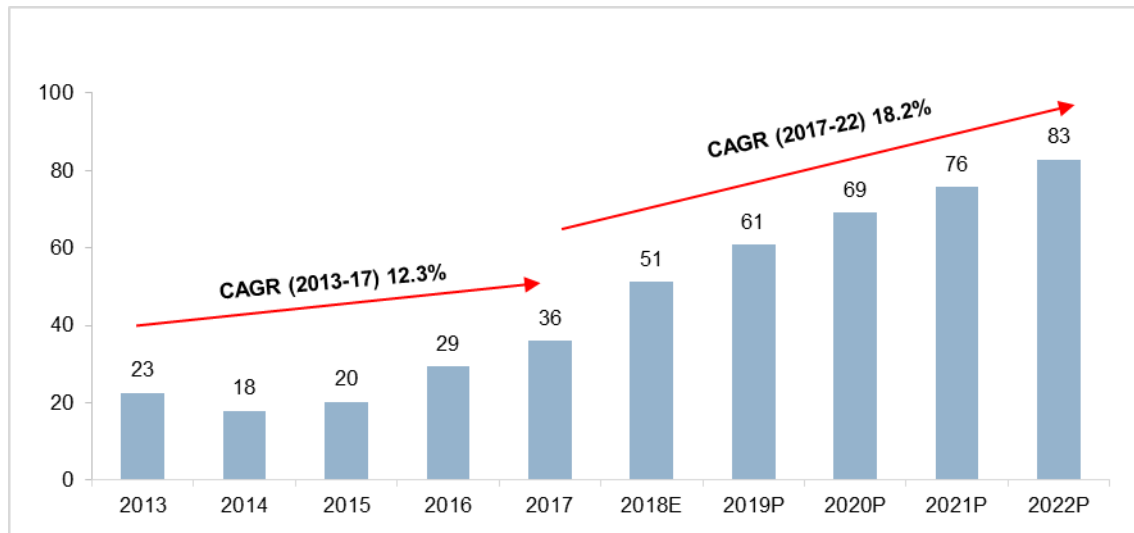

NOTE: For calculating market size of PMP, construction equipment such as backhoe loader, excavator, wheeled loader, skid steer loader, and rigid dump trucks have been considered.

Source: Industry, CRISIL Research

NOTE: The current market sizing for PMP includes only pins and bushes used in articulated joints. However, different vendors offer different levels of value addition and provide ancillary services to the OEMs based on their requirement, which could vary across model types and equipment categories. When we include the same (which would include child parts and services apart from manufacturing pins and bushes), the market size in 2017 would be pushed up to 25-35% i.e. US\$ 45-49 million depending on the value addition.

**Hydraulic Cylinders Market**

A hydraulic cylinder is an actuator that converts hydraulic energy into mechanical motion.

*Market Segmentation*

**Total Mobile Hydraulic Equipment Market: Percent Revenue Breakdown, Global, 2017**

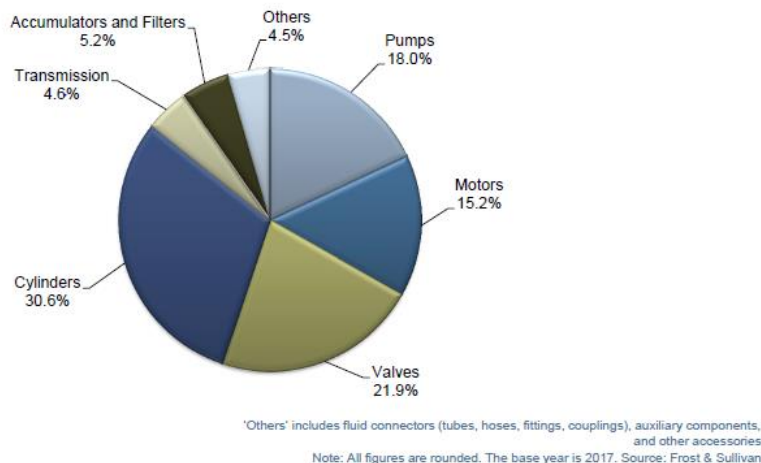



### Revenue Forecast Discussion for the Cylinders Segment

With a revenue share of 30.6%, hydraulic cylinders generated the highest revenue among the various product segments. Indirect sales through OEMs and distributors generates 80.5% of the total market revenue. Among the various mobile hydraulic product segments, the largest product segment was cylinders, which generated a revenue of US\$ 7,694.3 million in 2017. Cylinders are among the most important components in a hydraulic system, as they are the components directly responsible for motion control. The growth of cylinders in end-user industries such as aerospace and defense, construction, and agriculture is expected to help this segment grow at a CAGR of 4.3% to US\$ 9,895.5 million in 2023.

#### Total Mobile Hydraulic Equipment Market: Revenue Forecast for the Cylinder Segment, Global, 2014–2023

Product	2014	2015	2016	2017	2018	2019	2020	2021	2022	2023	CAGR (2017–2023)
Cylinders	7,450.4	7,149.7	7,046.6	7,694.3	8,226.2	8,653.5	8,967.2	9,279.2	9,578.0	9,895.5	4.3%

#### North American Hydraulic Equipment Market

The key drivers in the North American mobile hydraulic equipment market include the following:

- Higher demand for integrated hydraulic solutions offering enhanced control and flexibility is expected to aid the adoption of smart hydraulic systems
- Resurgence of US manufacturing and uptick in infrastructure projects to renew the demand for hydraulic equipment from traditional end-user industries
- Greater customer emphasis on single-vendor solutions throughout the lifecycle is expected to drive capital investment in hydraulic systems
- Increased focus on reducing the carbon footprint and increasing energy efficiency is expected to boost the demand for energy-efficient hydraulic equipment
- Trend towards miniaturization of mobile hydraulic equipment is expected to supplement the demand for compact, powerful hydraulic equipment

The key market restraints in the North American hydraulic equipment market include the following:

- Increasing innovation in alternative technologies threatens the adoption of hydraulic equipment
- Emergence of low-cost foreign suppliers add to the price pressure prevalent in the market
- Negative perception of hydraulics limits the adoption and expansion across newer applications and end-user industries
- Lack of significant product innovation causes price wars

In the North American mobile hydraulic equipment market, the market share for the cylinders product segment has remained steady ranging from 30.3 % in 2014 to 30.5 % in 2018 and is forecasted to remain steady with 30.6 percent in 2023.

Among the various mobile hydraulic product segments, the largest product segment was cylinders, which generated a revenue of US\$ 2,150.6 million in 2017. This equates to a share of 30.7% of the total market revenue. Cylinders are among the most important components in a hydraulic system, as they are the components directly responsible for motion control. The growth of cylinders in end-user industries such as aerospace and defense, construction, and agriculture is expected to help this segment grow at a CAGR of 5.1% to US\$ 2,893.8 million in 2023.

#### Total Mobile Hydraulic Equipment Market: Revenue Forecast for the Cylinder Segment, North America, 2014–2023

Product Segment	2014	2015	2016	2017	2018	2019	2020	2021	2022	2023	CAGR (2017–2023)
Cylinders	2,074.2	1,952.3	1,870.6	2,150.6	2,355.6	2,488.2	2,587.0	2,683.2	2,785.4	2,893.8	5.1%

### ***European (EMEA) Hydraulic Equipment Market***

The key drivers in the EMEA mobile hydraulic equipment market include the following:

- Higher demand for integrated hydraulic solutions offering enhanced control and flexibility is expected to aid the adoption of smart hydraulic systems
- Upcoming mega events in the Middle East such as Expo 2020 and the 2022 Soccer World Cup are expected to stimulate investments in new infrastructure and logistics
- Economic recovery in the EU and the introduction of stringent emissions standards for off-highway vehicles is expected to stimulate investments in new off highway machinery
- Increased focus on reducing the carbon footprint and increasing energy efficiency is expected to boost the demand for energy-efficient hydraulic equipment
- Trend towards miniaturization of mobile hydraulic equipment is expected to supplement the demand for compact, powerful hydraulic equipment

The key market restraints in the EMEA hydraulic equipment market include the following:

- Increasing innovation in alternative technologies threatens the adoption of hydraulic equipment
- Emergence of low-cost foreign suppliers add to the price pressure prevalent in the market
- Negative perception of hydraulics limits the adoption and expansion across newer applications and end-user industries
- Lack of significant product innovation causes price wars

In the European mobile hydraulic equipment market, the market share for the cylinders product segment has remained steady ranging from 31.1 % in 2014 to 30.9 % in 2018 and is forecasted to remain steady with 30.4 percent in 2023.

Among the various mobile hydraulic product segments, the largest product segment was cylinders, which generated a revenue of US\$ 3,382.7 million in 2017. This equates to a share of 31.0% of the total market revenue. The growth of cylinders in end-user industries such as construction, material handling, and aerospace and defense is expected to help this segment grow at a CAGR of 3.5% to US\$ 4,153.1 million in 2023.

*Total Mobile Hydraulic Equipment Market: Revenue Forecast for the Cylinder Segment, EMEA, 2014–2023*

Product Segment	2014	2015	2016	2017	2018	2019	2020	2021	2022	2023	CAGR (2017–2023)
Cylinders	3,284.5	3,152.9	3,143.1	3,382.7	3,582.0	3,758.6	3,863.7	3,970.4	4,056.6	4,153.1	3.5%

### ***Asia-Pacific (APAC) Hydraulic Equipment Market***

The key drivers in the APAC mobile hydraulic cylinders equipment include the following:

- Government initiatives such as the ‘Made in China 2025’ and the ‘One Belt One Road’ policy are expected to stimulate private investments in infrastructure and logistics sectors
- Increasing levels of mechanization in agriculture and material handling sectors are expected to increase the adoption of hydraulic systems
- End-user demand for greater energy efficiency and lower total cost of ownership is expected to increase the adoption of smart hydraulic systems
- Greater customer emphasis on one-stop-shop providers is expected to drive the adoption of mobile hydraulic equipment

The key market restraints in the APAC hydraulic cylinders market include the following:

- Heavy competition increases the price pressure in this market, stimulating a price war

- Increasing innovation in alternative technologies threatens the adoption of hydraulic equipment
- Lack of skilled labour limits product innovation and market growth

In the APAC mobile hydraulic equipment market, the market share for the cylinders product segment has remained steady ranging from 32.0 % in 2014 to 32.0 % in 2018 and is forecasted to remain steady with 31.9 percent in 2023.

Among the various mobile hydraulic product segments, the largest product segment was cylinders, which generated a revenue of US\$ 1,677.0 million in 2017 and holds a revenue share of 32.1%. The growth of cylinders in end-user industries such as construction, material handling, and agriculture is expected to help this segment grow at a CAGR of 5.0% to US\$ 2,253.7 million in 2023.

*Total Mobile Hydraulic Equipment Market: Revenue Forecast for the Cylinder Segment, APAC, 2014–2023*

Product Segment	2014	2015	2016	2017	2018	2019	2020	2021	2022	2023	CAGR (2017–2023)
Cylinders	1,575.0	1,563.9	1,567.9	1,677.0	1,784.8	1,884.1	1,977.5	2,068.7	2,160.6	2,253.7	5.0%

## OUR BUSINESS

*In order to obtain a complete understanding of our business, prospective investors should read this section in conjunction with “Risk Factors”, “Industry Overview”, and “Management’s Discussion and Analysis of Financial Condition and Results of Operations” on pages 21, 87 and 241, respectively. The industry related information contained in this section is derived from the CRISIL Report, which we commissioned for the purposes of confirming our understanding of the industry in connection with the Offer, except information pertaining to the hydraulics related industry, which has been derived from the F&S Report. Neither our Company, nor any other person connected with the Offer, including the BRLMs, has independently verified the information in the CRISIL Report or the F&S Report. See “Risk Factors – Internal Risk Factors – This Draft Red Herring Prospectus contains information from industry sources including a report commissioned from CRISIL Limited. Prospective investors are advised not to place undue reliance on such information” on page 43.*

*Unless otherwise stated, the financial information in this section is derived from our Restated Consolidated Financial Statements as at and for the six months ended September 30, 2018 and Fiscals 2018, 2017 and 2016.*

### Overview

We are a global manufacturer and supplier of engineering systems, solutions, assemblies and components, including 3-point linkage systems (“**3PL**”) and precision machined parts (“**PMP**”), primarily catering to off-highway vehicles (“**OHVs**”) in the agriculture, and construction, forestry and mining (“**CFM**”) sectors. Based on the median global addressable market sizes in calendar year 2017 stated in the CRISIL Report, we had an estimated 15.81% market share in the global 3PL market in Fiscal 2018 (in terms of value) and an estimated 9.02% market share in the global PMP market in the CFM sector in Fiscal 2018 (in terms of value) (assuming USD 1 = ₹ 64.46 for Fiscal 2018). In addition to our established product verticals of 3PL and PMP, we have a presence in the complementary product verticals of hydraulic cylinders and power take off (“**PTO**”) applications.

We have a global footprint and served OEMs across 25 countries during Fiscal 2018 in North and South America, Europe, Asia and Australia, including India. We primarily serve OEMs, through our global service delivery model based on our dual-shore integrated manufacturing, warehousing and supply chain management systems and solutions. We operate out of six manufacturing facilities (five in India and one in the United States) and three warehouses and one distribution facility and a raw material storage space located across three continents, which are strategically located in proximity to several global OEMs in the OHV industry. Sales from our manufacturing facilities in their respective domestic markets (“**Local Deliveries**”) contributed 35.08% and 36.54% of our revenue from operations for the six months ended September 30, 2018 and Fiscal 2018, respectively, while export sales from Indian locations directly to overseas customers (“**Direct Exports**”) contributed to 22.35% and 24.90%, respectively, and sales from our warehousing facilities in their respective domestic markets (“**Warehouse Sales**”) contributed to 38.45% and 34.66%, respectively, in the same periods.

We also cater to the aftermarket requirements of our customers. We provide replacements of 3PL parts to organized aftermarket retailers and distributors in North America, Europe, South Africa and Australia. By means of servicing our aftermarket segment customers, our products find indirect access to a large set up of retail stores across geographies for aftermarket components.

We believe that our diversified product range across the agriculture and CFM sectors, our market share, dual-shore integrated manufacturing, warehousing and supply chain solutions, together with our scale of operations and our technical, value and design engineering expertise, catering to several global OEMs as well as the aftermarket segment, serve to differentiate us from other producers of engineering systems. We believe we are well positioned to benefit from increasing mechanization in the agriculture and CFM sectors, in particular through leveraging our global service delivery model, which allows us to efficiently serve OEMs across multiple global locations, contributing to their increasing efforts to rationalize their supply chain and asset/working capital management.

We have long-term relationships with marquee global OEM players in the agriculture and CFM sectors, such as Deere & Company (“**John Deere**”), GKN Walterscheid GmbH (“**GKN**”), Tractors and Farm Equipment Limited (“**TAFE**”), Doosan Bobcat North America (“**Bobcat**”), Kubota Corporation (“**Kubota**”) and Yanmar Co. Ltd. We also have long-standing relationships with several respected organized aftermarket players in Europe and the US, such as Kramp. We also continue to add new customers to our portfolio. Some of the new marquee customers we have added since 2017 include Kobelco Construction Equipment India Private Limited (“**Kobelco**”) in the OEM segment and Tractor Supply Co. (“**TSC**”) in the aftermarket segment, in addition to one of the world’s leading construction equipment manufacturers in the OEM segment.

As part of our global service delivery model, we have set up manufacturing and warehousing facilities in India, the United States and Europe. In India, we have five manufacturing facilities, two at Ludhiana in the state of Punjab, one at Visakhapatnam in the state of Andhra Pradesh, and two at Noida in the state of Uttar Pradesh. We have also recently set-up a distribution facility and a raw material storage space in Noida in the state of Uttar Pradesh. In the United States, we have a manufacturing, warehousing and distribution facility at Eldridge in the state of Iowa, acquired pursuant to our acquisition in 2005 of Olsen Engineering LLC, now known as Uniparts Olsen Inc. (“**UOI**”) and a warehousing and distribution facility at Augusta in the state of Georgia. In Germany, we have set up a warehousing and distribution facility in Hennef, which serves

as our base for serving our key European customers. Further, we have leased additional area in Ludhiana, on which we are in the process of setting up a manufacturing facility.

We are promoted by first generation entrepreneurs, Gurdeep Soni, our Chairman and Managing Director, and Paramjit Singh Soni, one of our Executive Directors, who have over three decades of experience in this business.

Our revenue from operations for the six months ended September 30, 2018 and Fiscals 2018, 2017 and 2016 was ₹ 5,157.11 million, ₹ 8,461.86 million, ₹ 7,031.47 million and ₹ 7,795.20 million, respectively. Our earnings before interest, tax, depreciation and amortization (“**EBITDA**”) for the six months ended September 30, 2018 and Fiscals 2018, 2017 and 2016 was ₹ 783.24 million, ₹ 1,005.08 million, ₹ 679.28 million and ₹ 902.88 million, respectively, and our profit for the period/year for the six months ended September 30, 2018 and Fiscals 2018, 2017 and 2016 was ₹ 441.74 million, ₹ 535.33 million, ₹ 265.20 million and ₹ 447.12 million, respectively. Our sales in regions outside India (“**International Sales**”) accounted for 82.44%, 81.99%, 81.38% and 84.55% of our revenue from operations for the six months ended September 30, 2018 and Fiscals 2018, 2017 and 2016, respectively.

## **Our Strengths**

We believe the following are our principal competitive strengths:

### ***A leading market presence in the 3PL and PMP product verticals***

We have a presence in key markets worldwide, including North and South America, Europe, India and Japan. Based on the median global addressable market size for 3PL in calendar year 2017 stated in the CRISIL Report, we had an estimated 15.81% market share in the global 3PL market in Fiscal 2018 (in terms of value; assuming USD 1 = ₹ 64.46 for Fiscal 2018), serving some of the largest global companies, including John Deere, which has been our customer since 2001.

Our acquisition in 2005 of UOI enabled us to extend our reach in the construction industry and add the PMP vertical to our existing 3PL product portfolio and to diversify from the agriculture sector into the CFM sector. Based on the median global addressable market size in calendar year 2017 stated in the CRISIL Report, we had an estimated 9.02% market share in the global PMP market in the CFM sector in Fiscal 2018 (in terms of value; assuming USD 1 = ₹ 64.46 for Fiscal 2018). For instance, we have been able to leverage our leadership position and customer confidence to expand into the large construction equipment market, with new customers such as Kobelco as well as one of the world’s leading construction equipment manufacturers. We believe our leading presence in the 3PL and PMP verticals inspires customer confidence in our products, which is expected to fuel our growth going forward.

### ***Strong global service delivery model, through strategically located facilities in India, the U.S. and Europe***

We have set up our global service delivery model in a scalable manner, optimized to provide premium-priced Local Deliveries manufactured onshore in smaller lots and with shorter lead times, as well as cost-competitive offshore deliveries from India with longer lead times and inventory cycles. Our global service delivery model serves as an effective solution for customers seeking to rationalize their global sourcing and supply chain by providing them multiple choices in the form of Local Deliveries, Direct Exports and Warehouse Sales, while at the same time helping us to manage costs and increase our margins.

With our facilities in India, the U.S. and Europe being strategically located in proximity to several global OEMs in the OHV industry, we believe that we are well-positioned to provide timely deliveries tailored to customer specifications in terms of their production schedules, geographical needs, applications, vehicle sizes and technical specifications, and to provide customized packing, warehousing and kitting solutions and logistical support to our customers. We believe that our global presence gives us access to our customers on a localized basis and has played a key role in strengthening relationships that we have developed with them over a period of time. Our global service delivery model also enables us to diversify our margins based on different delivery models for the same product, and effectively functions as an entry barrier for new entrants into this business. Our Warehouse Sales as a percentage of our revenue from operations has increased in the last five Fiscals, to 34.66% in Fiscal 2018 and 38.45% during the six months ended September 30, 2018. We seek to leverage our global service delivery model and continue to focus on increasing sales from Direct Exports and Warehouse Sales.

### ***Long-term relationships with marquee global customers, including major OEMs***

We have developed long-term relationships with marquee global customers in the agriculture and CFM sectors, such as John Deere, GKN, TAFE, Kubota and Kramp. Our top five customers (based on contribution to our revenue from operations during Fiscal 2018) have been our customers for an average period of over 14 years. John Deere, GKN, TAFE and Kramp are some of the customers with whom we have had relationships for over 15 years, while with customers like Kubota and Yanmar Co. Ltd., we have developed relationships for over 10 years. Our business with some of our more recent customers such as Kobelco, TSC and one of the world’s leading construction equipment manufacturers, has increased since we added them to our customer portfolio, reflecting our ability to develop and strengthen relationships with customers. We believe that the strength of our customer relationships is attributable to our ability to customize to customer specifications and

requirements, as well as our track record of consistent delivery of quality and cost-effective products and solutions through our strategic alignment with our key customers' goals and specifications over the years.

We believe that our customers have unique requirements and preferences. Therefore, we seek to partner with our key customers at various stages of product development, commencing from product design, through validation and testing up to final manufacturing and delivery, and we seek to capitalize on our existing customer base to achieve cross-selling of our products across our business verticals. This also helps us understand customer requirements and future plans better, enabling us to forecast, plan and manufacture our products accordingly, thereby resulting in business optimization, improved productivity, efficiency and margins.

We have wide and deep relationships with our key OEM customers. Over the years, for various OEM customers, we have developed relationships and received orders from multiple business divisions and locations globally, including through our efforts to cross sell different products to our global OEM customers. Our manufacturing, designing and testing capabilities coupled with the capability to leverage our global service delivery model has helped us develop and maintain long-term relationships with a number of our customers. We believe that our relationships with global OEM customers that command significant market share would enable us to access a corresponding share of the OHV markets in the future.

### ***Backward and forward integrated operations***

We are significantly backward integrated with our operational processes. Our in-house development, manufacturing and implementation capabilities range from design, product validation, procuring raw steel to forging operations, machining, heat treatment, surface coating and assembly. At the same time we are sufficiently forward integrated with our warehousing and logistics capabilities which facilitate the delivery of finished products to our customers either directly from our manufacturing facilities or through our warehouses in the U.S. and Europe.

We operate out of six manufacturing facilities (five in India, across Ludhiana, Visakhapatnam and Noida, and one in the U.S., in Eldridge, Iowa) and three warehousing and distribution facilities across the U.S. and Europe and one independent distribution facility and a raw material storage space in Noida, India, thus benefiting from economies of scale of operations and integration across our operations. One of our Noida facilities and our Visakhapatnam facility, are located in SEZs, and are dedicated to our export operations. Our Ludhiana facilities are the hub for our Indian domestic market and a source of machined forgings and structural fabrications for our other Indian facilities, and are the first level of processing for a majority of our products. One of our Noida facilities serves as a hub for our aftermarket sales in the U.S. and Europe, while the other serves as a hub for our domestic and exports OEM sales. Our Visakhapatnam facility serves as a hub for our export OEM sales. In the United States, we have a manufacturing, warehousing and distribution facility at Eldridge in the state of Iowa and a warehousing and distribution facility at Augusta in the state of Georgia. In Germany, we have set up a warehousing and distribution facility in Hennef, which serves as our base for serving our key European customers.

Our significant backward and forward integration limits our dependence on external supply and support services and enables maintenance of quality controls required to service global OEMs and aftermarket players.

### ***Concept-to-supply solutions across the OHV component value chain***

We are present across various levels of the OHV component value chain, providing concept-to-supply solutions for our customers. Over the years, we have evolved from a component supplier to a provider of complete assemblies of precision engineered products and end-to-end solutions ranging from product conceptualization, design, prototyping, testing, development and assembly to customized packaging and delivery, thus becoming an integral part of some of our major customers' global supply chains.

We collaborate with our key customers on an ongoing basis, across all of our facilities, on joint product development and process innovation programs, to upgrade and customize our products in tandem with customer specifications and requirements. This collaboration in design and on-site engineering is undertaken during the design and concept stage to suit the end product configuration as well as applicable regulatory requirements. We work jointly with our customers in multiple areas, including product designing, testing and prototyping, which, in turn, helps us in developing long term relationships with them.

We also believe that we obtain significant operational synergies and efficiencies through horizontal and vertical integration of our operations, including in terms of secure connectivity and an Enterprise Resource Planning (“ERP”) system implemented across our operations in the U.S., Germany, Visakhapatnam, the Noida facilities and in one of our facilities in Ludhiana. The ERP system is under implementation at the other Ludhiana facility.

### ***Strong financial position and diversified business model with a proven ability to sustain industry cycles***

We have a strong financial position, which we believe we have achieved due to our market position and our diversified product verticals, industry presence, geographic footprint and fiscal prudence.

Our revenues are diversified across geographies, given our presence in Indian and international markets, across industry sectors and across product verticals, with our two established product verticals being 3PL and PMP, and our two emerging verticals being hydraulic cylinders and PTO applications. Our sales in the Americas accounted for 56.54%, 54.05%, 54.05% and 57.97% of our revenue from operations during the six months ended September 30, 2018 and Fiscals 2018, 2017 and 2016, respectively. During the same periods, our sales in Europe accounted for 16.95%, 19.66%, 18.16% and 16.57%; India accounted for 13.45%, 14.11%, 15.04% and 12.12% and Japan accounted for 4.43%, 3.96%, 4.61% and 5.60% of our revenue from operations, respectively. Sales of 3PL contributed to 47.48%, 48.66%, 48.61% and 49.27% of revenue from operations and PMP contributed to 46.79%, 44.91%, 44.20% and 44.09% of our revenue from operations during the six months ended September 30, 2018 and Fiscals 2018, 2017 and 2016, respectively. During the same periods, our sales to the agriculture sector comprised 59.34%, 61.54%, 62.00% and 62.10% and sales to the CFM sector comprised 36.20%, 34.21%, 34.10% and 34.27% of our revenue from operations, respectively. We have also leveraged our production and process capabilities to deliver specific components to a customer in the oil and gas industry. Our sales in the aftermarket segment comprised 13.42%, 11.07%, 11.94% and 12.67% of our revenue from operations during the six months ended September 30, 2018 and Fiscals 2018, 2017 and 2016, respectively.

Our revenue from operations for the six months ended September 30, 2018 and Fiscals 2018, 2017 and 2016 was ₹ 5,157.11 million, ₹ 8,461.86 million, ₹ 7,031.47 million and ₹ 7,795.20 million, respectively. Our EBITDA for the six months ended September 30, 2018 and Fiscals 2018, 2017 and 2016 was ₹ 783.24 million, ₹ 1,005.08 million, ₹ 679.28 million and ₹ 902.88 million, respectively, and our profit for the period/ year for the six months ended September 30, 2018 and Fiscals 2018, 2017 and 2016 was ₹ 441.74 million, ₹ 535.33 million, ₹ 265.20 million and ₹ 447.12 million, respectively. During the same periods, our total debt to equity ratio was 0.81, 0.68, 0.61 and 0.78 and our total debt to EBITDA ratio was 4.00, 2.46, 2.87 and 2.55.

We have been able to achieve strong financial performance as well as demonstrate our ability to maintain operating margins and sustainable debt levels despite the global financial crisis that began in 2008 and the agricultural and CFM sector slow-down between 2014 and 2016. According to the CRISIL Report, while revenues for some of the key OEMs in the agriculture and construction equipment industry declined at a CAGR of 5-7% between 2013-2017, our revenue from operations increased at a CAGR of 1% between Fiscals 2014 and 2018. We believe that such proven ability to sustain our financial performance and perform better than the end markets, even during unfavourable industry cycles, is largely a result of our diversified business model, coupled with our consistent efforts to add new customers while also increasing the ticket size of our business with existing customers, improving margins due to global service delivery model and operational efficiencies.

We are committed to continuing to diversify our product offerings, customer base and geographical footprint, thereby minimizing our exposure to individual geographies, industry sectors, customers, product platforms and foreign currencies.

#### ***Experienced and qualified team of professionals***

We believe that we benefit significantly from our highly experienced management and technical teams, including, in particular, our Promoter and Chairman and Managing Director, Gurdeep Soni (who is in charge of our aftermarket business), our Promoter and one of our Executive Directors, Paramjit Singh Soni (who is in charge of OEM business, inorganic growth and strategic initiatives), who each have over three decades of experience in this business; our Group Chief Operating Officer, Sudhakar S Kolli (who is in charge of our overall operations, business development and marketing), who has over 22 years of experience in the areas including general management with leadership role and operations and product development; and our Director, Herbert Coenen (who is in charge of business development, marketing and technology advancement), with over 30 years of experience in the international OHV market, and in the industry and the markets in which we operate. Our management team is strategically located in key end markets with Paramjit Singh Soni in the U.S., Gurdeep Soni and Sudhakar S Kolli in India and Herbert Coenen in Europe (Germany).

Our senior management has extensive experience in operations, business development and quality, customer relationship and human resource management. Our management and technical personnel are supported by other skilled workers who benefit from regular in-house and onsite training initiatives. As on September 30, 2018, we had 254 full-time employees having engineering degrees while 240 others are technical diploma holders and 76 have other professional qualifications. Our personnel policies are aimed towards recruiting talented individuals, facilitating their integration, and promoting the development of their skills. In addition to regular compensation, statutory benefits and standard insurance coverage, we have an employee stock option plan designed to motivate and incentivize our key employees.

For details of our management and key managerial personnel, see “*Our Management*” beginning on page 143.

#### **Our Strategies**

We are committed to continuing to increase our market share across our product verticals and to diversify our product offerings, customer base and geographical footprint, thereby minimizing our exposure to particular sectors, markets and customers. Towards this objective, our growth and competitive strategies are as follows:

### ***Increasing share of customer spend per vehicle***

Our focus is on increasing our content per vehicle (i.e., the number of components supplied by us in OHVs produced by our OEM customers) and to expand the size of the addressable market through product development. In particular, we seek to expand sales of 3PL products in the higher horsepower (>60HP) tractor segment and to increase our sales of PMP into the large construction equipment segment, as well as add sales of hydraulic cylinders and PTO applications to our existing customers. In addition, all our product categories are complimentary to at least one of the other product verticals and we believe this will help us in cross selling and increasing our share of customer spend per vehicle. We believe that being a leading supplier of both 3PL and PMP products acts as an enabler for us to cross-sell to our customers. For instance, for one of our customers, we initially started our relationship by supplying 3PL products in Japan. We expanded our relationship by supplying products for the construction segment to this customer in Japan, as well as in Germany. Subsequently, we have also supplied 3PL products to this customer in India. Towards implementation of our strategy to expand sales of 3PL in the higher horsepower (>60HP) tractor segment, we have recently added a test-rig for this segment. We are also expanding our presence in the large construction equipment market by manufacturing large pins for one of our new customers, Kobelco. We seek to continue to nurture relationships with our customers and evolve from single geography or a particular product to a multi-geography or multi-product association with a long-term strategic alignment.

### ***Increasing geographical penetration and increasing addressable market***

According to the CRISIL Report, the global addressable market for 3PL was US\$ 390-410 million in calendar year 2017, which is estimated to grow to US\$ 580-600 million in 2022, while the global addressable market for PMP was US\$ 475-516 million in calendar year 2017, which is estimated to grow to at a CAGR of 6% between 2017-2022. We constantly seek to enhance our addressable markets with our global service delivery model and work closely with our customers on new product development, process innovation and customized delivery and service solutions. Towards this objective, we seek to expand our presence with OEMs in India in the PMP, PTO and hydraulic cylinders verticals, while maintaining and expanding our presence in the 3PL vertical. In the international markets, we intend to focus on strengthening our presence in the PMP vertical, by developing products for large construction equipment, in geographies where our 3PL sales have been growing, including Europe and Japan. We also seek to further expand our 3PL presence in Japan in the <60HP segment and in Europe by developing products for the >60HP segment. As we were already serving OEMs in 25 countries globally in Fiscal 2018, we seek to increase our presence in these and other adjacent geographies by continuing to leverage our proven global service delivery model which enables us to manufacture an increasing number of our products from our manufacturing facilities in India at competitive prices for our customers globally, and increase our margins at the same time.

In addition, expanding in the aftermarket segment forms an integral part of our vision for achieving diversified growth. When we service our large aftermarket segment customers such as TSC and Kramp, our products find indirect access to a large set up of retail stores across geographies for aftermarket components. We expect our ability to support our aftermarket customer requirements with a blend of delivery options and customized services to further our growth in this market segment.

### ***Targeting new customer accounts and expanding existing customer accounts***

We intend to increase our sales and customer penetration by targeting new customer accounts and expanding our existing customer accounts in our principal markets by offering our entire range of products. Towards this objective, we seek to continue to consolidate and develop our relationships with large and renowned global OEMs whose product portfolios are spread across industries such as agriculture, CFM and industrial equipment, as well as our value engineering and process innovation competencies so as to be able to enter new and related markets and acquire, evolve and strengthen our customer relationships. In particular, we believe that the CFM sector offers us the opportunity to target new customers for our products. According to the CRISIL Report, global growth in the construction equipment industry between 2017-2022 is expected to be driven by North America (at a CAGR of 9%) and India (at a CAGR of 14%), due to higher expected investment in infrastructure projects. We have recently expanded our customer portfolio by adding Kobelco and one of the world's leading construction equipment manufacturers in the OEM segment and TSC in the aftermarket segment. We believe that we will be able to capitalize on our reputation for quality, consistent performance and customer satisfaction in our existing markets and product verticals to target new customers.

### ***Inorganic growth via strategic acquisitions and alliances***

We intend to continue our strategy to explore opportunities for forward integration, including selectively evaluating targets for strategic acquisitions and investments, in order to strengthen our position as an integrated, full system solutions provider for the agriculture and CFM sectors. Through this objective we seek to strengthen our product platform and customer portfolio.

We believe that we have benefited significantly from our strategic acquisition in 2005 of UOI, which catalyzed the growth of our PMP product vertical and our sales to the CFM sector. Our investment in Kavee (a joint venture with Kramp, a long-term customer that we continue to supply to), which ceased to be our subsidiary with effect from April 1, 2012, also contributed significantly to our acquisition of product and process knowledge for our hydraulic cylinders vertical.



Our strategy is to acquire businesses with high growth and performance potential, along with their existing customer relationships and product and process competencies, and to integrate and grow their businesses through enhanced quality and delivery parameters, engineering support, integration of IT systems and ERP platforms with manufacturing support from India, coupled with our management know-how and experience. While we will also evaluate any opportunistic acquisitions that are viable, our primary strategy is to focus on identifying financially stable and performing assets for acquisition. In particular, we intend to explore opportunities in Europe, which would give us a manufacturing base in the continent, as well as opportunities in the U.S. to complement our existing business. We may also seek to expand our international warehousing and distribution operations, based on demand and delivery logistics in various geographies, to fuel our growth going forward. We believe that we have been successful in acquiring and integrating overseas assets and ventures in the past and will continue to benefit from such initiatives, thereby expanding our product portfolio, market share, customer base and geographical footprint.

#### ***Enhancing engineering, innovation and design competence***

We endeavor to focus on process and product innovation and value engineering solutions in order to meet the requirements of a wider range of vehicles, geographies, applications and other customer specifications, so as to strengthen and diversify our customer and product portfolio.

Towards this objective, we seek to continue to improve our in-house value engineering, testing, design and process innovation capabilities through human resource and technical development, as well as exploring opportunities for collaboration and inorganic growth and continuing to work closely with our key customers to upgrade and customize our products, in particular, to increase sales of 3PL products in the higher horsepower (>60HP) tractor segment and of PMP, hydraulic cylinders and PTO applications, while maintaining and improving our market share in the 3PL and PMP verticals.

#### ***Enhancement of manufacturing and warehousing capacities and capabilities***

We intend to continue to invest in physical and operational infrastructure to meet incremental demand for our products and solutions from our customers and to enable us to grow our revenues and profits. Along with exploring opportunities for inorganic growth, as discussed above, we seek to continue to improve of capacity utilization and product and process efficiency parameters at our existing facilities. For instance, we have recently expanded our owned warehousing facility in Augusta, Georgia (with the addition of 8.00 acres). We also expanded our warehousing facility in Hennef, Germany, which is now set up on an aggregate area of 2,063.68 sq. mts. We have also added a distribution facility and a raw material storage space in Noida, set up across two plots, across an aggregate area of approximately 2.20 acres. This strategy is aimed at growing and leveraging on our global service delivery model, as well as expanding sales to new customers in international markets where we do not currently have a prominent presence. We have also leased land in Ludhiana, close to our existing facility in Ludhiana, for a new manufacturing facility of approximately 0.92 acres.

#### **Our Products and Solutions**

We manufacture products under four verticals, 3PL, PMP, hydraulic cylinders and PTO. Set forth below are details of our sales of finished goods across market segments, product verticals and geographies for the six months ended September 30, 2018 and Fiscals 2018, 2017 and 2016:

(₹ in million)

<b>Particulars</b>	<b>Six months ended September 30, 2018</b>	<b>Fiscal 2018</b>	<b>Fiscal 2017</b>	<b>Fiscal 2016</b>
<b>Revenue split across market segment</b>				
Agriculture segment	3,060.24	5,207.05	4,359.71	4,840.84
CFM segment	1,867.10	2,894.99	2,397.66	2,671.36
Others	17.33	29.92	22.33	23.04
<b>Revenue split across product vertical</b>				
3PL	2,448.47	4,117.35	3,418.18	3,841.04
PMP	2,412.78	3,799.94	3,107.58	3,436.55
Hydraulic cylinders	13.35	25.60	19.11	15.59
PTO applications	42.99	98.74	83.19	87.90
Others – including fabrication	27.08	90.33	151.63	154.15
<b>Revenue split across geographies</b>				
Americas	2,915.67	4,573.39	3,800.79	4,518.59
Europe	874.26	1,663.50	1,276.79	1,291.58
India	693.40	1,193.87	1,057.75	944.64
Japan	228.67	335.07	323.89	436.91
Asia-Pacific	101.39	134.75	117.75	114.81
Rest of the world	131.29	231.38	202.73	228.71

### 3PL

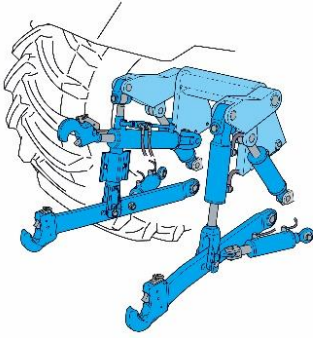

**3PL systems**

The 3PL system forms a group of assemblies allowing an implement like a plough to be attached to the tractor at three coupling points, forming a triangle. Most tractors are equipped with a 3PL system and are classified according to International Organization for Standardization (“ISO”) 730 in four categories, based on the engine rating. The 3PL transfers the entire load, which can be a multiple of the implement weight, between the tractor and implement. The parts are highly loaded and exposed to fatigue as well as wear and tear, in particular in the joints, due to movement under high load condition. The primary function of the 3PL is to transfer the weight and load of an implement to the wheels of a tractor and to allow the adjustment of different positions by lifting and lowering the implement.

The 3PL comprises different parts:

- Two lower arms called draft link or lower link, forming two out of the three coupling points;
- Two lift rods connecting the two lower links with two lift arms, which are not part of the 3PL but form part of the hydraulic lift. The hydraulic lift is powered and allows lowering and lifting of the 3PL;
- One top link or center link, acting as a connecting rod and forming the third coupling point; and
- Stabilizer systems controlling the lateral movement of the lower links.

The design of a 3PL and its integration into the tractor is tractor specific, and each tractor model has its own design features in terms of geometry, size, and features, and each model can be equipped by the tractor manufacturer with different configurations based on final point of use. The geometry and size in terms of cross sections used is not only dependent on the engine rating and expected loads to be transferred, but also largely dependent on the design of the transmission, rear axle and tyres to be used. The 3PL has to interface with these boundary conditions and has to fit to the connecting points of the tractor, which are not standardized in any form.

The features of a 3PL design are highly dependent on the market that it serves. The design features of a 3PL can be broadly classified as follows:

- *Standard:* Basic design of all components with simple joints to connect the implement to the tractor, used on low horsepower tractors and in the economy segment.
- *Telescopic:* In this design, the lower links do not have standard ball joints at the interfacing joining the implement, but a device allowing the slip end to be disengaged and then joined to the implement by having the tractor positioned in a certain proximity to the implement. In this configuration, the top link is usually a standard design with basic ball joints at the implement end.
- *Quick Coupler:* The lower links are equipped with a claw allowing the operator to remain in the operator station and to connect or disconnect an implement from the operator station, which has significant advantages with regard to safety and comfort, in particular considering the size and weight of implements connected to a tractor.
- *Frame Coupler:* This is a version of a quick coupler using a frame/single piece joined with the implement. This configuration is primarily a North American specification.

We presently supply components as well as complete 3PL systems for standard and telescopic configurations and components, as well as semi-complete 3PL systems for quick coupler and frame coupler configurations, with an intention to supply complete solutions for the latter two configurations in the future.

We have three manufacturing facilities in India, producing 3PL. Our two Noida facilities serve as our hub for the domestic market and also serves export customers. Our Visakhapatnam facility primarily serves export customers, in particular for the higher horsepower range in Europe and North America.

Our sales distribution of 3PL across key markets for the six months ended September 30, 2018 and the last three Fiscals is set forth below.

	Six months ended September 30, 2018	Fiscal 2018	Fiscal 2017	Fiscal 2016
Americas	17.21%	15.15%	14.85%	18.81%
Europe	11.77%	15.01%	14.90%	13.77%
India	13.37%	13.50%	13.33%	10.69%
Japan	1.61%	1.63%	1.80%	2.61%
Asia Pacific	1.51%	1.09%	1.23%	1.15%
Rest of the world	2.00%	2.27%	2.50%	2.24%
3PL sales as a percentage of our revenue from operations	47.48%	48.66%	48.61%	49.27%

### Production Processes

Our manufacturing processes range from pre-machining processes like die-forging, upset-forging, pressing, punching, bending and cold drawing to machining processes performed on conventional or computer numerical control (“CNC”) equipment for turning, milling, thread rolling and cutting, spline cutting, broaching, grinding as well as laser cutting, welding, heat treatment, surface finishing and assembly. The heat treatment process varies depending on customer specifications and intended applications. For instance, we apply through hardening on all structural parts to increase the implement’s load carrying capability; we apply case carburizing on parts that are in the joints and exposed to wear and tear; and we apply induction hardening to achieve higher case depth in combination with high tensile strength material to have high load bearing capability along with wear resistance. Most of our products in this vertical are supplied in plated condition. Among other capabilities, we also offer finished products, E coated and painted with superior salt spray resistance.

### PMP

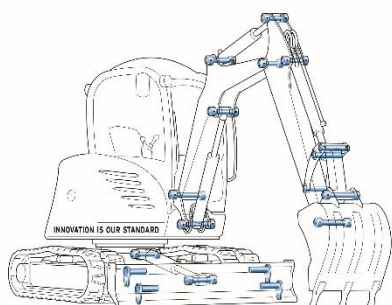

**PMP in articulated joints**

PMP is a group of components that require stringent material and manufacturing specifications and controls, used in applications across OHVs, ranging from engine parts and transmission components to particular parts for joints in agricultural and construction applications. Of our construction PMPs, the majority is used in articulated joints (hinges) where arms, booms and cylinders are attached to each other. These articulated joints are the single largest application of PMP for us. The size varies in terms of weight from <1kg per part to >100kg per part depending on the application we service. The significant difference of this product range as compared to 3PL is the comparatively lower complexity in their bill of material, and that PMP parts are predominantly individual parts with significant load bearing capability and not a complete assembly of multiple parts, as compared to a 3-point linkage system comprising of multiple assemblies. Due to the complex design and high degree of precision required in PMP products, they lack standardization and the number of variants in this product vertical is very high.

We have four manufacturing facilities producing PMP in India, one each at Visakhapatnam and Ludhiana and two at Noida. In addition, our facility at Eldridge, Iowa serves the North American market, with local production as well as warehousing of products manufactured in and exported from India.

Our sales distribution of PMP across key markets for the six months ended September 30, 2018 and the last three Fiscals is provided below.

	Six months ended September 30, 2018	Fiscal 2018	Fiscal 2017	Fiscal 2016
Americas	38.65%	37.94%	37.94%	38.18%
Europe	4.33%	3.71%	2.38%	1.89%
India	0.05%	0.06%	0.13%	0.05%
Japan	2.83%	2.34%	2.81%	3.00%
Asia Pacific	0.38%	0.43%	0.45%	0.32%
Rest of the world	0.55%	0.42%	0.49%	0.64%
PMP sales as a percentage of our revenue from operations	46.79%	44.91%	44.20%	44.09%

### Production Processes

The standard production process for PMP products ranges from cut-off machines, CNC or conventional machining, heat treatment and grinding, followed by welding, if required, and finishing operations such as hardening and plating. We differentiate to a certain extent between our facilities in India and in Eldridge, depending on our in-house capability for pre-machining operations and other processes. For instance, at our Eldridge facility, the first operation is usually cutting or parting by means of high-speed circular saws and cut-off centers, where the first machining operation is performed during the parting operation itself. Our Eldridge facility has dedicated in-house machining, grinding, welding, induction hardening and

plating capabilities. In contrast, our Indian facilities have certain manufacturing cells and equipment such as machining, grinding and welding dedicated to PMP products, while also utilizing shared resources with other product verticals for bulk processes such as heat treatment and plating.

### Hydraulic Cylinders

Hydraulic cylinders are used as actuators to move mechanized components, by generating linear motion along an axis. Hydraulic cylinders are powered by a fluid, typically water or oil. We primarily manufacture hydraulic cylinders powered by oil. Hydraulic cylinders may be ‘double acting’ hydraulic cylinders, which are powered to extend or reduce the length, or ‘single acting’ hydraulic cylinders, which are only powered to move in one direction. Plunger cylinders form a subcategory of single acting cylinders, using the rod as a piston, where the rod is only slightly smaller than the inner diameter of the tube.

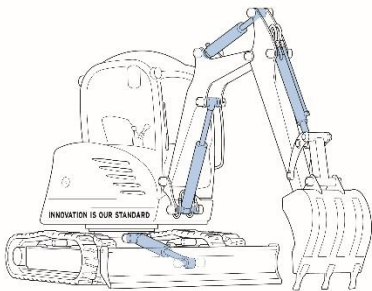

Although all or several of our customers possess in-house competence for manufacturing hydraulic cylinders, we believe that there is still significant demand, in particular in international markets, for hydraulic cylinders due to increased mechanization and transitions in technology, and that the following factors have led to that trend:

- Size and weight of equipment;
- Complexity of equipment and the application;
- Comfort; and
- Safety.

### Hydraulic Application

We manufacture double acting as well as single acting (including plunger cylinders) hydraulic cylinders, with a focus on applications in farm equipment, tractors, attachments and smaller size construction equipment like mini excavators and skid steer loaders. In particular, we seek to focus on applications that are synergetic to our existing applications and existing customers. An example for synergies with existing activities are hydraulic top links, which are a special design used in the 3PL application by the aftermarket as a retro fit and also by OEMs in lieu of mechanical top links. Another example is lift cylinders, which are used in the hydraulic lift of a tractor. In addition, many of our PMP applications interface with cylinders. We believe that the development of such synergetic products allows us not only to enter the hydraulic segment but also to extend our market share in our existing 3PL and PMP verticals. Our increasing diversification into the hydraulic cylinders vertical is part of our strategy to increase our content and customer spend per vehicle.

We have established hydraulic cylinder manufacturing capabilities at our Visakhapatnam facility, to serve our international as well as domestic customers.

### Production Processes

The manufacturing process is split into machining, including turning, milling and welding (where standard machines are used, fine-tuned to cater to the length of the component), followed by assembly and testing. Hydraulic cylinders are required to qualify for cleanness requirements, for which we apply ultrasonic washing, followed by assembly in a clean room and testing and painting.

### PTO



### PTO Application

PTO is a device used to drive implements such as rotary tillers, mowers and other equipment requiring a mechanical drive by the tractor. the PTO transmits power from the tractor to the implement and is used to distribute the power within the machine. The PTO is implement-specific and part of the implement and, therefore, each implement has one main shaft and, in many cases, secondary shafts to distribute the power within the implement. We are currently focused on producing PTO for the

agriculture sector, which allows the transfer of power from the tractor to the implement. This product is a low-speed shaft used at standard speeds ranging between 540rpm and 1000rpm. It comprises four functional groups:

- two joints – one at each side;
- telescopic members connected to the joints, allowing the shaft to change its length during operation;
- overload clutch to protect the implement and tractor from damage; and
- safety guard to protect the operator and to avoid any material from getting wound around the shaft.

The design and features of PTO used for agricultural purposes are different from PTO shafts used in commercial truck or industrial applications. They differ in operating speed, joint design, design of telescopic members and the guard, which is mandatory, and are required to comply with international safety norms. The initial applications are rotavators, reapers, pumps and threshers. According to ISO standards, PTOs are classified into different sizes and power ratings specifying the power and torque that they are able to transmit.

We manufacture PTO components at our Ludhiana facility, for OEMs as well as for sale in the aftermarket.

### Production Processes

The production processes involved include turning and milling of castings and forgings used in joints and flanges, followed by broaching and hobbing. The machining of components is followed by painting and assembly with a guarding shielding all rotating items which prevent accidents.

### Operations

Our growth model has been based on our evolution from being a supplier of components into now being an integrated provider of complete product assemblies and concept-to-supply solutions across the OHV component value chain, as well as being a dual-shore manufacturer and supplier of engineering systems, solutions, assemblies and components to global OEM customers, based on a process of continuing vertical and horizontal integration, while at the same time using our traditional aftermarket access to wholesalers and distributors and expanding it with warehousing services to service retail chains directly.

The schematic below sets out our presence across the concept-to-supply solutions value chain.

Integrated solutions provider present across various levels of the OHV component value chain

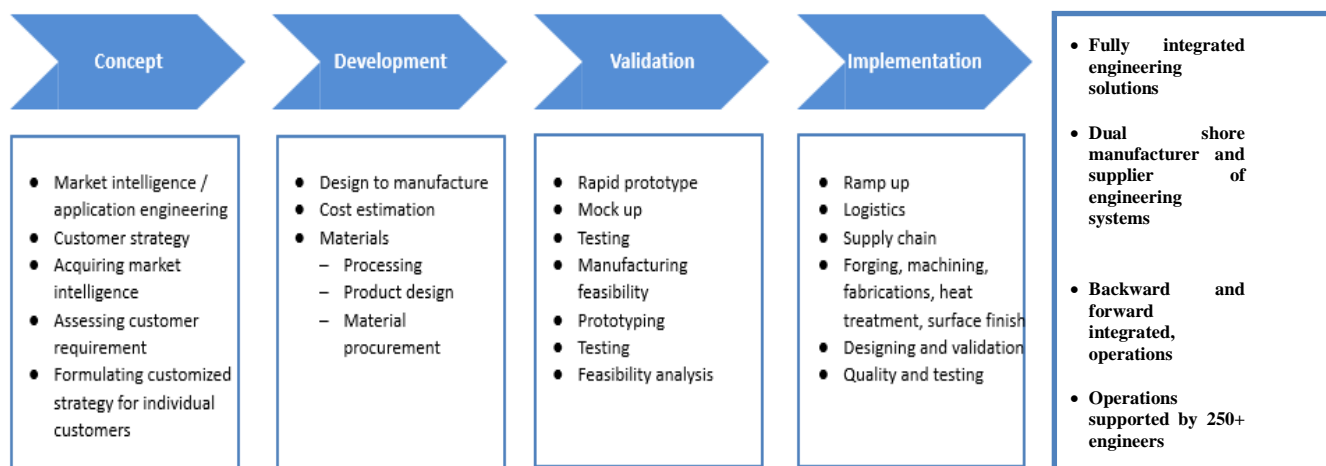

Key highlights of our history are as follows:

- Promoters commenced business in 1984.
- Promoters set up the facility at Ludhiana in two phases in 1990 (through Farmparts Company (partnership firm)) and 1993 (through SKG Engineering Private Limited).
- Incorporation of our Company in 1994.
- Farmparts Company (partnership firm) started manufacturing components for the U.S. aftermarket customers in 1997.

- Commenced sales to domestic OEMs in the agricultural segment in India and developed our 3PL OEM product vertical in 2000.
- Established the first facility in Noida in 2000.
- Commenced sales to John Deere in India in 2001.
- Commenced sales to John Deere in Europe 2002.
- Commenced sales to John Deere in Americas in 2003.
- Consolidated all the businesses in Uniparts India Limited in 2005, including those of GFPL, Farmparts Company (partnership firm) and SKG Engineering Private Limited, and consolidated the business of Sweaty Spirit Apparel Limited (formerly known as Ace Tractor Parts Limited) in Uniparts India Limited in 2007.
- Acquired a manufacturing and distribution facility in Eldridge, Iowa in the U.S., in 2005.
- Set up a warehousing and distribution facility in Augusta, Georgia, U.S., in 2005.
- Commenced manufacturing products for the PMP vertical in India, in 2006.
- Acquired 50% + 1 share equity interest in Kavee (a joint venture with Kramp), which owned 100% interest in Uniparts Kavee Services B.V., in 2007.
- Started manufacturing hydraulic cylinder components in one of the Noida facilities in 2007.
- Commenced our operations at the Visakhapatnam facility, which is situated within an SEZ, in 2008.
- Set up a warehousing facility and distribution facility in Hennef, Germany, which has been operating since 2010.
- Commenced sale of components for the European construction OEM market in 2012.
- Added raw material storage space in Noida, in 2017.
- Added TSC as a customer in the aftermarket segment in 2017.
- Enhanced the manufacturing capacity of SKG Unit at Ludhiana by taking additional space in 2017.
- Commenced sales to Kobelco in 2018.
- Added additional distribution centre and office space in Noida, in 2018.
- Added warehousing space at our facility at Augusta, USA in 2018.

We offer fully integrated engineering solutions from conceptualization, development and validation to implementation and manufacturing. The conceptualization stage involves acquiring market intelligence, assessing customer requirement and formulating customized strategy for individual customers. The development phase includes product designing, material procurement and processing. This is followed by the validation phase, which involves prototyping, testing and feasibility analysis. Our in-house manufacturing and implementation competencies include forging, machining, fabrications, heat treatment, surface finish, logistics, quality and testing, design and validation.

OEM sales accounted for 82.46%, 85.03%, 84.48% and 84.00% of our revenue from operations for the six months ended September 30, 2018 and Fiscals 2018, 2017 and 2016, respectively. Sales to our top 10 customers accounted for 77.01%, 77.01%, 77.72% and 79.34% of our revenue from operations for the six months ended September 30, 2018 and Fiscals 2018, 2017 and 2016, respectively. We serve our OEM customers from all of our manufacturing, warehousing and distribution facilities, across all our product verticals. We believe that over the years, we have strengthened our customer engagement with key OEM customers and offered them multiple products across multiple locations. For the six months ended September 30, 2018 and Fiscals 2018, 2017 and 2016, 62.21%, 64.43%, 58.97% and 61.91%, respectively, of our revenues comprised sales to customers to whom we sell both 3PL and PMP.

Aftermarket involves providing product replacement (due to wear and tear) and certain add-on parts to the end user over the full life cycle of the equipment, after the original purchase is made. Within the aftermarket category, we are focused on the 'will-fit' parts segment, sold to distributors like Kramp as well as farm and fleet stores such as TSC. Aftermarket sales accounted for 13.42%, 11.07%, 11.94% and 12.67% of our revenue from operations for the six months ended September 30, 2018 and Fiscals 2018, 2017 and 2016, respectively. One of our Noida facilities serves as a hub for our aftermarket sales in

the U.S., Europe, South Africa and Australia. The aftermarket customers are serviced through Direct Exports and Warehouse Sales.

**Global Service Delivery Model**

The chart below illustrates our dual-shore multiple delivery model:

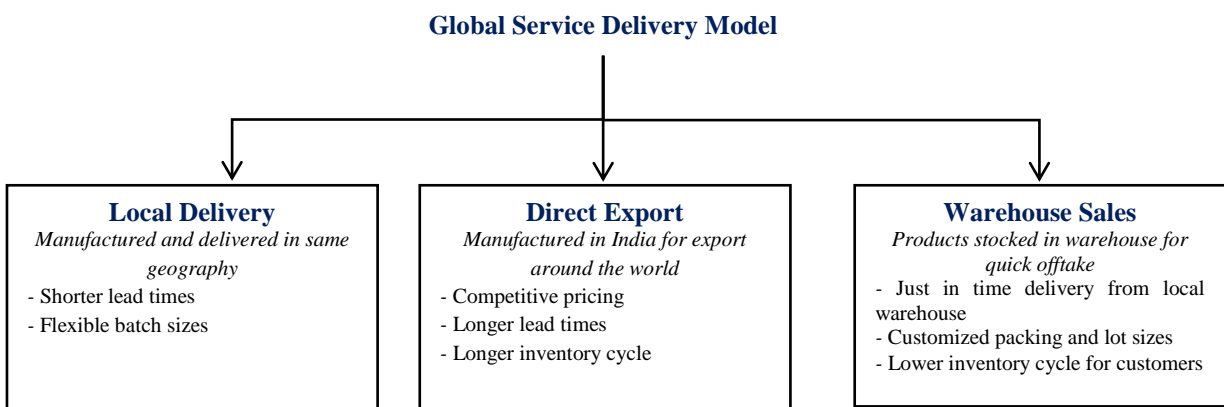

Local Deliveries contributed to 35.08%, 36.54%, 38.27% and 38.11% of our revenue from operations for the six months ended September 30, 2018 and Fiscals 2018, 2017 and 2016, respectively, while Direct Exports contributed to 22.35%, 24.90%, 26.49% and 27.26%, respectively, and Warehouse Sales contributed to 38.45%, 34.66%, 31.66% and 31.30%, respectively, in the same periods.

Our global service delivery model has contributed significantly in the evolution of our relationships with our key customers, as we are able to serve multiple delivery locations and provide multiple delivery options with flexible lead times and costs, allowing us to better serve our customers with multiple price points based on different delivery models. We have a track record of nurturing customer relationships, commencing from a single geography or a particular product and gradually evolving over the years to a multi-geography or multi-product association with a long-term strategic alignment.

**Our manufacturing, warehousing and distribution facilities**

The map below illustrates our manufacturing, warehousing and distribution facilities worldwide:

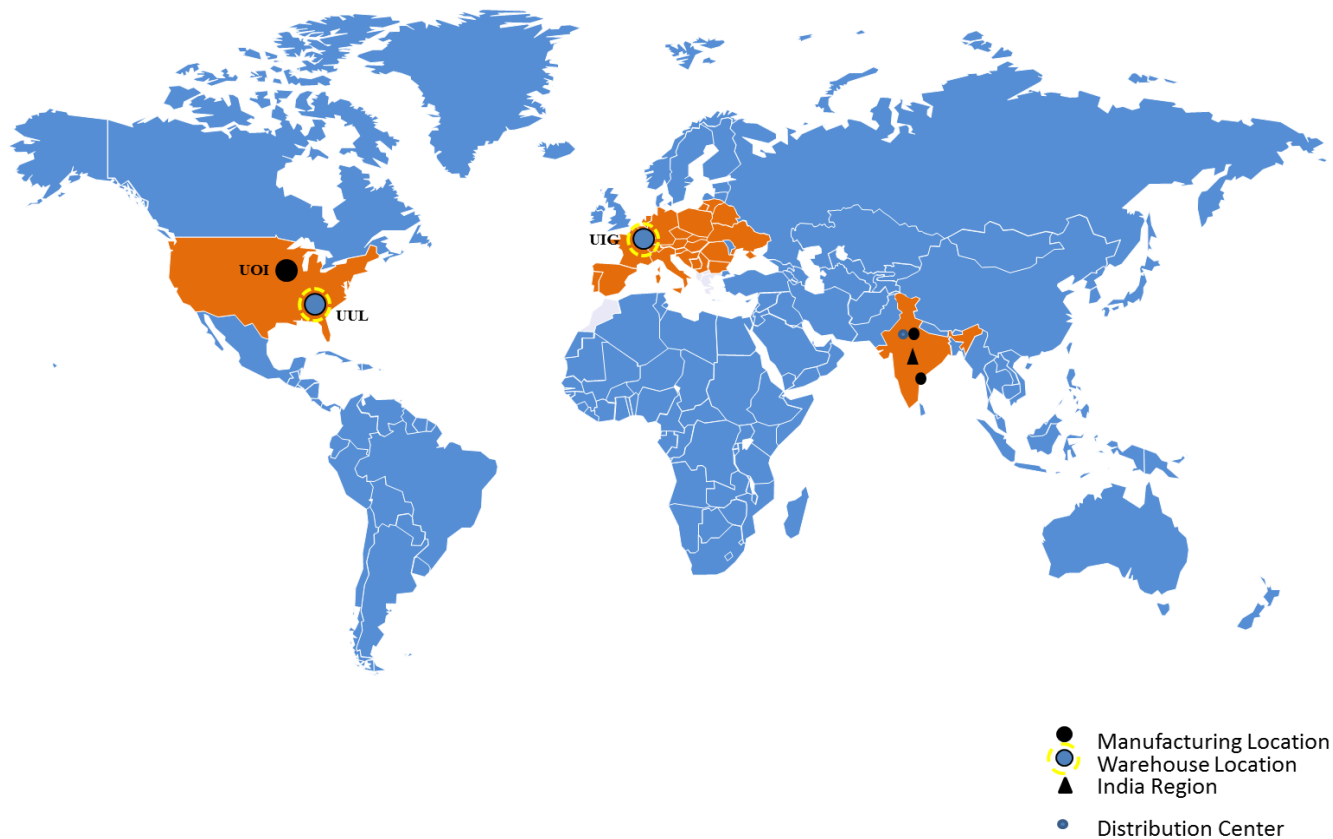

### *Ludhiana*

We currently have two manufacturing facilities in Ludhiana, in the state of Punjab in India, established in 1990 and 1993, covering an aggregate area of approximately 4.47 acres and an aggregate built-up area of approximately 180,544.13 sq. ft. We have recently expanded one of our Ludhiana facilities, thereby enabling it to cater to our domestic business as well. In addition, we have recently leased additional area at Ludhiana, on which are in the process of setting up a new manufacturing facility.

Our ISO 9001:2015 certified Ludhiana facilities are our source of machined forgings (hammer, upset and metal gathering), advanced die and tool building with PRO Engineer backend support for components/sub-assemblies and structural fabrications for OEM in India and our other India facilities, and is the first level of processing for a majority of our products for our other Indian facilities and also serve as a hub for our domestic sales. Our Ludhiana facility also manufactures PTO products and precision machined oil and gas plungers.

At our Ludhiana facilities, we have in-house heat treatment (continuous induction pit furnace and GCF furnaces), CNC and vertical machining center (“VMC”) machining, robotic welding and special purpose machinery, metal inert gas welding, pulsating welding and butt welding. We have deep hole gun drilling, spline rolling and hobbing capabilities. Advanced fabrication shop for light to heavy duty applications, painting, plating, zinc and manganese phosphating and plastic dip coating.

Power for this facility is sourced from the local grid, with backup from our on-site diesel generators.

### *Visakhapatnam*

We have a manufacturing facility in Visakhapatnam, in the state of Andhra Pradesh in India. Our Visakhapatnam facility was commissioned in Fiscal 2009 and is situated within an SEZ and dedicated to our export operations. The operations of the facility are managed on a fully integrated ERP system. This is an integrated facility and is our largest facility and is located across an aggregate area of approximately 30 acres and an aggregate built-up area of 300,008.04 sq. ft., including 85,577.14 sq. mts. of unutilized area available for scaling up of our operations. In addition to the unutilized area available for scaling up of our operations, certain manufacturing processes including heat treatment and plating, were built to accommodate any such expansion or capacity creation.

This ISO 14001:2015 and ISO 9001:2015 certified facility is equipped with bar code technology for production reporting and material handling and serves as a hub for our export OEM sales. Our Visakhapatnam facility manufactures 3PL, PMP and hydraulic cylinders, primarily for the agriculture and CFM sectors. At our Visakhapatnam facility, we have in-house capacity for cold drawing, CNC machining, laser cutting and welding (including butt and robotic welding), heat treatment (sealed quench furnace), induction hardening, shot blasting, grinding, painting, plating, metallurgical laboratory, hydraulic assembly clean room.

Power for this facility is sourced from the local grid, with backup from our on-site diesel generators.

### *Noida*

We have two manufacturing facilities in Noida, in the state of Uttar Pradesh in India, established in two phases in Fiscal 2000 and Fiscal 2006. These facilities are set up across two plots, across an aggregate area of approximately 8.17 acres and an aggregate built-up area of approximately 194,406.00 sq. ft. One of our two facilities in Noida is located within an SEZ dedicated to our export operations and is operated by us through our Subsidiary, GFPL. These facilities primarily serve the 3PL and PMP segments, primarily for the agriculture and CFM sectors. Both the Noida facilities are also equipped with bar code technology for production reporting and material handling and are managed on a fully integrated ERP system.

Both these facilities are ISO 9001:2015 and ISO 14001:2015 certified. One of our Noida facilities serves as a hub for our aftermarket sales in the U.S. and Europe and the other serves as a hub for our domestic and export OEM sales.

At our Noida facilities, we have in-house capacity for conventional and CNC and VMC machining processes, welding (including butt and robotic welding), induction hardening, grinding, shot blasting, heat treatment (continuous and pit furnace), plating, painting, ED coating and assembly. We have added a complete cell at one of our facilities to produce pins for construction equipment weighing up to >100 Kgs. We have a metallurgical lab at one of our Noida facility and a complete test rig both for <60HP and >60HP tractor segments.

Power for this facility is sourced from the local grid, with backup from our on-site diesel generators. The operations of the facility are managed on a fully integrated ERP system.

### *Eldridge, Iowa*



We have a manufacturing, warehousing and distribution facility in the United States, in Eldridge, Iowa, acquired pursuant to our acquisition in 2005 of UOI. This facility has been set up across an aggregate area of approximately 9.52 acres and a built-up area of approximately 136,481.00 sq. ft. In addition, we have leased additional area of approximately 77,611 sq. ft. of built-up area to be utilized for warehousing purposes.

This ISO 9001:2015 certified facility serves as a hub for our sales of PMP products for the agriculture, construction, and material handling sectors for OEMs in the U.S., and has an in-house induction hardening capability in addition to machining (precision turning, drilling, milling, grinding, and welding) and other related finishing processes. This facility primarily serves the North American market, with local production as well as warehousing and distribution of products manufactured in and exported from India.

Our manufacturing core competencies at this facility include induction hardening, zinc plating, cold saw metal cutting systems, various CNC operation on turn mill centers as well as machining centers, grinders with inline automated inspection and packing and automated welding, allowing us to produce products in a wide range of sizes and fatigue loads, for various applications and duty cycles. PMP products such as precision pins, hardened bushings and structural bosses represent a majority of our product mix at this facility. Other smaller segments of the product mix include tube fabrication as well as miscellaneous precision CNC machined parts.

Power for this facility is sourced from the local grid.

***Our other warehousing and distribution facilities***

*Augusta, Georgia*

We currently have a 6.20 acre warehousing and distribution facility in the U.S., in Augusta, Georgia (acquired in 2005), and have recently, in 2018, leased 8.00 acres of additional warehousing and distribution space in close proximity, with the intention of ceasing use of the existing facility, after the new space becomes operational. This warehousing facility is completely managed by our own resources and systems and processes. This facility is completely integrated through our ERP systems and is also equipped with bar coding infrastructure for efficiency optimization.

This facility serves as our base for serving our North and South American customers.

*Hennef, Germany*

We have a 2,063.68 sq. mt. warehousing and distribution facility in Europe, in Hennef, Germany, which has been which has been taken on lease since Fiscal 2011. This facility is completely integrated through our ERP systems and is also equipped with bar coding infrastructure for efficiency optimization.

This facility serves as our base for serving our key European customers.

*Noida*

We have a distribution facility in Noida, established in Fiscal 2018 across an area of approximately 1.24 acres. In addition, we established a unit for raw material storage in Noida in Fiscal 2018, which is spread across approximately 0.96 acres. The aggregate built-up area across these two facilities is 73,700 sq. ft.

**Installed Capacity and Capacity Utilization**

Set forth below are details of the product-wise installed capacity of our manufacturing facilities as of September 30, 2018, March 31, 2018, March 31, 2017 and March 31, 2017, and production volumes and capacity utilization for the Fiscal 2018, 2017 and 2016.

Manufacturing facility	Installed capacity as on September 30, 2018	Installed capacity as of March 31, 2018	Fiscal 2018		Installed capacity as of March 31, 2017	Fiscal 2017		Installed capacity as of March 31, 2016	Fiscal 2016	
			Production	Capacity utilization (%)		Production	Capacity utilization (%)		Production	Capacity utilization (%)
B-208, Noida, Uttar Pradesh India	16,500	14,400	13,019	90%	14,400	10,711	74%	14,400	9,629	67%
GFPL, Noida, Uttar Pradesh, India	6,000	6,000	4,877	81%	6,000	3,474	58%	6,000	3,880	65%
Vishakhapatnam, Andhra Pradesh, India	13,440	12,840	9,508	74%	12,840	7,172	56%	12,840	8,950	70%
Farmparts, Ludhiana, Punjab, India	9,000	7,800	8,465	109%	7,800	6,508	83%	7,800	6,453	83%

Manufacturing facility	Installed capacity as on September 30, 2018	Installed capacity as of March 31, 2018	Fiscal 2018		Installed capacity as of March 31, 2017	Fiscal 2017		Installed capacity as of March 31, 2016	Fiscal 2016	
			Production	Capacity utilization (%)		Production	Capacity utilization (%)		Production	Capacity utilization (%)
SKG, Ludhiana, Punjab, India	12,000	6,600	6,243	95%	6,600	4,957	75%	6,600	5,427	82%
Eldridge, Iowa, USA., UOI	7,200	7,200	4,726	66%	7200	3,520	49%	7,200	5,245	73%

Note: Since our Company is in discrete manufacturing, the total capacity of the unit is worked out on the basis of the total output of each intermediate process. Hence, in the event that there are any bottlenecks in an intermediate process and a part of the process gets outsourced, then the overall capacity can exceed 100.00%. In case of our Farmparts unit at Ludhiana, at times the forging process becomes a bottleneck and to address this issue, we have an outsourcing forging capacity of up to 300 tons per month.

## Raw Materials

**3PL:** The raw material used by us for the 3PL vertical primarily includes steel bars, which we convert to forgings or use as blanks for machining, steel flats, steel tubes and castings.

**PMP:** The raw material used by us in the PMP vertical primarily includes steel bars in solid or tubular geometry, or steel plates or strips, including laser cut or punched material. Forgings are also used as input material for some PMP variants. The grades we use are low and medium carbon steel, case carburizing steels and alloy steels. The steel used by us as raw material is procured by us primarily in cold drawn form in the U.S. and in hot rolled form in India. At our Visakhapatnam facility, we perform cold drawing as an in-house operation and for our in-house consumption only.

**Hydraulic cylinders:** The raw material used by us for the hydraulic cylinders vertical primarily includes hydraulic cylinder tubes, procured in honed or roller burnished condition, hard chrome bar and forgings, as well as castings for components like piston, glands, joints and hydraulic seals.

**PTO Applications:** The raw material used by us in PTO applications primarily includes steel bars, forgings and castings. The PTO requires plastic shielding to prevent accidents.

Steel is the main and key raw material for us. We have a diverse portfolio of vendors supplying steel and we are not significantly dependent on any single vendor. Steel accounted for 68.77%, 69.85%, 69.08% and 70.36% of our raw material purchases in value terms for the six months ended September 30, 2018 and in Fiscals 2018, 2017 and 2016, respectively. The steel sourced in India accounted for 47.42%, 48.04%, 46.28% and 43.13% and our expenditure on steel sourced in U.S accounted for 21.34%, 21.81%, 22.79% and 27.23% of our raw material purchases in value terms for the six months ended September 30, 2018 and in Fiscals 2018, 2017 and 2016, respectively.

For our Indian manufacturing operations, we source steel directly from Indian steel mills. We have also developed a supply chain for sourcing specific forms of steel from China, for our manufacturing facilities in India. Steel used for products manufactured in our facility at Eldridge, Iowa, is primarily sourced in the U.S. from distributors.

We have limited exposure to fluctuation in the global steel prices as our long-term agreements with several key customers provide for adjustment in raw material prices as per predefined method based on movement of identified commodity index.

Procurement functions for our Indian operations are divided between our strategic sourcing team and our procurement team.

**Strategic sourcing:** This team in India is centralized and focuses on strategic aspects, such as new vendor development, price negotiations, procurement cost saving initiatives, enhancing sourcing efficiencies, vendor rationalization and sourcing related internal process establishment. The team is also involved in cross leveraging inter-regional and inter-plant knowledge and information to ensure efficient and real time decision making, as well as bringing about economies of scale. Our strategic sourcing team had a total of 20 employees as on September 30, 2018.

**Procurement:** This team is decentralized and is located at each of our manufacturing facilities. The procurement team at each of our facilities is responsible for ensuring procurement planning, raw material inventory management and vendor management. Our procurement teams worldwide were comprised of 56 employees as on September 30, 2018.

## Value Engineering and Process Innovation

We differentiate ourselves from other component suppliers through our in-house value engineering and process innovation capabilities, supported by product development programs undertaken jointly with some of our key customers, translating into our diversified presence across sectors, markets and product verticals. Over the years, we believe that we have become an integral part of the global and local supply chains of some our key customers.

In particular, we have benefited from our strategic acquisition of UOI in 2005, which catalyzed the growth of our PMP product vertical and our growth in the CFM sector. We continue to collaborate with our key customers on joint product

development and process innovation programs, to upgrade and customize our products in tandem with customer specifications and requirements.

Our Director, Mr. Herbert Coenen, is in charge of business development and technology advancement, and is supported by several highly skilled and experienced personnel. As on September 30, 2018, we had 254 full-time employees having engineering degrees, while 240 others are technical diploma holders, and 76 have other professional qualifications.

### **Business Development and Sales**

We have a global footprint, serving OEMs and the aftermarket across six continents, including emerging markets such as South America and India. Our largest geography in terms of sales has been the Americas, which accounted for 56.54%, 54.05%, 54.05% and 57.97% of our revenue from operations during the six months ended September 30, 2018 and Fiscals 2018, 2017 and 2016, respectively. During the same periods, our sales in Europe accounted for 16.95%, 19.66%, 18.16% and 16.57%; India accounted for 13.45%, 14.11%, 15.04% and 12.12% and Japan accounted for 4.43%, 3.96%, 4.61% and 5.60% of our revenue from operations, respectively. Sales of 3PL contributed to 47.48%, 48.66%, 48.61% and 49.27% of revenue from operations and PMP contributed to 46.79%, 44.91%, 44.20% and 44.09% of our revenue from operations during the six months ended September 30, 2018 and Fiscals 2018, 2017 and 2016, respectively. During the same periods, our sales to the agriculture sector comprised 59.34%, 61.54%, 62.00% and 62.10% and sales to the CFM sector comprised 36.20%, 34.21%, 34.10% and 34.27% of our revenue from operations, respectively.

OEM sales accounted for 82.46%, 85.03%, 84.48% and 84.00% of our revenue from operations during the six months ended September 30, 2018 and Fiscals 2018, 2017 and 2016, respectively. Our marquee customers, with many of whom we enjoy long term relationships include John Deere, GKN, TAFE and Kubota.

We have entered into long-term agreements with key OEM customers, which are typically valid for a period of up to three years, while we supply our products to our other OEM customers on the basis of purchase orders, depending on the customer's preference and standard practice. Our supply arrangements with our key OEM customers typically provide for periodic price review of our products (generally bi-annual, or quarterly in certain cases). This would largely include price resets on the basis of raw material price changes and changes in the foreign exchange rates. Additionally, we may be required to provide an annual cost reduction in relation to our products to some of our OEM customers. Our key customers also typically have centralized strategic sourcing teams, supported by various regional sourcing and procurement teams. Therefore, we believe that our dual-shore multiple delivery models (including premium-priced Local Deliveries manufactured onshore in smaller lots and with shorter lead times, as well as cost-competitive offshore deliveries from India with longer lead times and greater inventory cycles), together with our customized packing, shipping, delivery and other logistics solutions are a key component of our sales and marketing initiatives and also effectively function as an entry barrier for other suppliers that do not have the benefit of a global service delivery model of the kind that we have built and developed over the years. We have also entered into warranty agreements with certain of our key OEM customers.

Aftermarket sales accounted for 13.42%, 11.07%, 11.94% and 12.67% of our revenue from operations during the six months ended September 30, 2018 and Fiscals 2018, 2017 and 2016, respectively. We have long standing relationships with several leading players in the aftermarket segment in Europe and U.S., such as Kramp.

Our business development team is centralized and is led by our Director, Mr. Herbert Coenen. Our business development team focuses on identifying and developing customer relationships and securing new contracts. Our business development team had a total of 33 employees as on September 30, 2018.

The sales and customer service function is decentralized at each physical location that ships out products to our customers. With strong customer orientation and commitment, we endeavor to constantly meet high standards of delivery and response time as per the expectations of our customers. Our sales teams worldwide were comprised of a total of 28 employees as on September 30, 2018.

As we expand into newer geographies, we plan to have additional warehouses, our own team or marketing representatives to ensure our presence in the same geography as the end customers, so as to strengthen our customer relationships.

### **Warranty Arrangements**

We have also entered into warranty agreements with certain key OEM customers, where we have long-term supply arrangements with such customers. To the extent that such OEM customers provide a warranty to their end users and incur warranty costs for non-conformity of their products to agreed specifications or standards, our supply arrangements with our OEM customers typically allow us to review warranty claims in order to determine if the failure was caused by a manufacturing defect in our products. If it is determined that the failure was on account of a manufacturing defect in our products, we are typically required to promptly correct or replace those defective products at our own expense and prepare a written corrective action plan, failing which, we may be required to reimburse our OEM customers at part acquisition cost, with additives to cover administrative, labor, material and other such costs. We have designed our warranty policy to ensure

customer satisfaction. The standard warranty period for our products is 12 to 24 months but, in the case of certain specified types of equipment in which our components are used, may extend to 36 months or longer.

With certain OEM customers, we may also be required to follow performance improvement programs, whereby, if a particular product or batch of products is not found conforming to the specified quality standards, the product is replaced, followed by a correction program.

Where we have not entered into warranty agreements with certain of our customers, our customers can raise debit notes equal to or more than the selling price of the products that are rejected and physically returned to us or scrapped at the customer's end after our approval. While we maintain insurance coverage, including a product liability insurance, in keeping with what we believe to be the industry standard, we may not be sufficiently insured against punitive damage awards. In 2016, we settled a claim for US\$ 1.68 million from one of our customers relating to a specific part supplied by us, for which we had outsourced the heat treatment. For details, see "*Risk Factors - An adverse determination in a significant product liability or performance improvement claim or significant replacement costs may adversely affect our business, financial condition, results of operations and prospects*" on page 29.

### **Quality Control, Environment and Occupational Health & Safety**

Each of our facilities in India as well as our facility in Eldridge, Iowa, is ISO 9001:2015 certified. This standard specifies requirements for a quality management system. Both of our manufacturing facilities in Noida and our facility in Visakhapatnam are also ISO 14001:2015 certified. This standard specifies requirements for an environmental management system.

We are committed to following applicable environmental and occupational health and safety laws as well as industry best practices. In accordance with the terms of our supply arrangements with our key customers, we are also committed to maintaining acceptable safety and quality systems, specifications and standards set by those customers, including the requirement for on-time delivery and for on-site and off-site inspections of our products and facilities by our customers.

### **IT and Management Tools**

For bringing synergies between our facilities engaged in forward as well as backward integrated supply chain, we have invested in ERP systems, implemented across our operations in the U.S., Germany and our facilities in India (except one manufacturing facility at Ludhiana, where this is currently under implementation). We also have business intelligence tool under implementation in order to enable key metrics and performance dashboards available at a click of a button. In addition, the business critical IT Infrastructure is hosted at a renowned tier-3 data centre with 24x7 monitoring and service support. We have three-tier secure access and network connectivity across locations, disaster recovery and business continuity plans, and a facility and asset management system, all of which facilitates integration intra-group as well as with customer systems. Our IT systems are managed by an in-house IT team. We believe that the resulting automation and transparency has strengthened the scalability of our operations worldwide and will help us in achieving synergies from strategic acquisitions and investments that we may undertake in the future.

We explore and adopt efficiency enhancement tools, including electronic data interchange ("**EDI**") infrastructure. We undertake and foster data analytics and data-based decision making. We have implemented strategy deployment framework across all our operating locations thereby ensuring that process and employee level goals are completely aligned to the short and long term organizational strategy and objective.

### **Awards and Recognitions**

We have received several prestigious awards and certifications from our customers, including 'Best Supplier Award' from TAFE in 2014 and 'Kubota India GM Award - 2014' from Kubota. Our Subsidiary, UOI has been inducted in the 15 years hall of fame (1991-2005) by John Deere and it has also been inducted in the 10 years hall of fame (1991-2000) by John Deere Davenport Works.

Further, we have also received a recognition from JCB at the JCB Annual Supplier Conference in 2010. In 2013, our facility at Visakhapatnam was awarded the first prize at the CII Kaizen Competition and in 2016, our Company was awarded at the 7<sup>th</sup> National Kaizen Competition with Special Kaizen Award by the Chamber of Industrial and Commercial Undertaking. In addition, we also received the 'Company with Great Managers' trophy from The Times of India Group in 2016. We have also received several awards for excellence in exports performance from EEPC India (formerly, the Engineering Export Promotion Council, set up under the sponsorship of the Ministry of Commerce and Industry, India).

Our Company received the 'Best Supplier Award' in 2018 for outstanding contribution in co-creating value by TAFE. In 2018, we were also awarded a special trophy for excellence in exports of MEIS items by EEPC. At the 2018 CICU Kaizen competition, we were awarded the second prize in the Poka-Yoke to complete electrical circuit for welding process and a special prize for quality improvement. Our Company has also been recognized as a three-star export house by the Ministry of Commerce and Industry, Government of India until 2020, as per the Indian Foreign Trade Policy 2015-2020.

## Competition

While there are several producers of varying size serving certain segments or sub-segments of our customer base, across agriculture and CFM, and there are also several producers of varying size manufacturing certain of the products that we sell, in various geographical markets, we believe that we have no peers that operate in the full spectrum of our customer base, geographical market, product range and price points. We also believe that our ability to offer end-to-end solutions to our customers (such as entire 3PL assemblies), instead of individual components, and our emphasis on the global service delivery model to meet our customers' varying requirements, differentiate us from our competition and also effectively function as an entry barrier for suppliers that do not have the benefit of a global service delivery model of the kind that we have built and developed over the years.

The CRISIL Report states that some of the players for PMP include General Grind & Machine (headquartered in Illinois, U.S.), Società Italiana Boccole Srl (headquartered in Bologna, Italy), Vishal Engineers (headquartered in Haryana, India), while those for 3PL include CBM Group (headquartered in Modena, Italy), GNK plc (headquartered in Redditch, Worcestershire, United Kingdom), Maxiforja Componentes Automotivos (headquartered in Canoas, Brazil), Sudtrac Linkages (headquartered in Haryana, India), Delica Co., Ltd. (headquartered in Matsumoto, Japan).

As the parameters of competition in this business are less firmly established than in certain other types of businesses and there are no standard methodologies to assess this industry as far as we are aware, we believe that it is difficult to predict how the competitive landscape of our business will develop over the long term. General competitive factors in the market, which may affect the level of competition over the short and medium term, include vulnerability to overall macroeconomic factors, time to market, availability of after-sale and logistics support, product features, design, quality, price, delivery, warranty, general customer experience and relationships between producers and their customers.

## Employees

As on September 30, 2018, we had an aggregate of 2,529 employees, out of which 825 employees were in the regular staff category and 1,704 employees were in the regular labour category. Set out below are details of our regular staff employees, as split by location and professional qualifications.

<b>Total number of regular staff employees</b>	<b>825</b>
<b><i>Split By Location</i></b>	
India	767
Overseas	58
<b><i>Split by Professional Qualification</i></b>	
Engineering degrees	254
Technical diploma holders	240
Other professional qualifications	76
Others	255

Additionally, as on September 30, 2018, we also utilized the services of 1,804 persons engaged as contract labour and 231 engaged as apprentice.

We currently do not have any registered trade unions at any of our facilities.

We are dedicated to the development of the expertise and know-how of our employees. Our personnel policies are aimed towards recruiting talented individuals, facilitating their integration, and promoting the development of their skills, including through in-house and on-site as well as external training programmes. In addition to compensation that includes salary and allowances, our employees receive statutory benefits (including employees' provident fund, employees' state insurance, pension, retirement and gratuity benefits, workman's compensation, maternity and other benefits, as applicable) and are covered by group accident and health insurance.

## Insurance

We maintain insurance policies with independent insurers in respect of our buildings, plant and machineries, fixtures and fittings, other equipment and inventories. The coverage under such insurance policies is in respect of losses due to fire (including standard fire and allied perils) and burglary, for amounts that we believe are in keeping with industry standard. We also have availed of fidelity guarantee and money insurance policies.





We cover our employees under group accident and medical insurance programs, except in respect of locations where our workforce is covered under the ESI scheme.

Under our supply arrangements with our key OEM customers, the risk of loss to the raw materials procured by us as well as to the products supplied by us typically remains with us until the title, risk and rewards and control on our products passes from us to such customers. Therefore, we maintain marine insurance for our exports, imports and domestic sales and purchases. Further, as our supply arrangements with certain of our key OEM customers require us to maintain product

liability insurance, we maintain comprehensive general liability insurance which includes product liability, product recall, product guarantee and financial loss coverage with independent insurers. We also maintain public liability insurance against the statutory liability arising out of accidents due to handling hazardous substances.

We do not presently maintain insurance for business interruption. We maintain insurance for directors and officer's liability across all our locations.

### Intellectual Property

We have four registered trademarks, of which we use “”, “” and “”, as a stamp on our products and “” as our corporate logo. All our trademarks are registered in our name, except for “”, which is registered under the name of one of our Subsidiaries, GFPL.

We currently do not have any registered patents or copyrights. We also protect designs and drawings for our products through non-disclosure agreements that we enter into with our customers.

### Immovable Properties

The brief details of our owned and leased immovable properties are set out below:

S. No.	Location	Use	Approximate Plot Size (in acres unless mentioned otherwise)	Nature of Right /Title	Lease Period	Addresses
1	Farmparts, Ludhiana, Punjab, India	Manufacturing facility	2.25	Owned	Of the 1.18 acres, 0.59 acres has been leased with effect from August 10, 1997 to August 9, 2096. The remaining portion of the plot is a freehold property of our Company.	D-126-A, 127-A Phase-V, Focal Point, Ludhiana 141 010, Punjab
2	Farmparts, Ludhiana, Punjab, India			Owned	The plot comprising of 1.06 acres has been leased with effect from January 19, 1993 to January 18, 2092.	Plot No. C-140, Phase-V, Focal Point, Ludhiana-141 010, Punjab
3	SKG, Ludhiana, Punjab, India		Owned	The 2.22 acre consists of 2 plots, 0.97 acre leased with effect from March 5, 1998 to March 4, 2097 and 1.25 acres has been leased with effect from July 21, 1988 to July 20, 2087.	C-197, 198, Phase-VII, Industrial Focal Point, Dhandari Kalan, Ludhiana-141 010, Punjab	
4	SKG, Ludhiana, Punjab, India		Leased	0.29	The lease is valid with effect from November 1, 2018 to October 31, 2023.	E-488, Phase-VI, Focal Point, Ludhiana- 141 010, Punjab
5	Ludhiana, Punjab, India		Leased	0.92	The lease is valid with effect from February 1, 2018 to January 31, 2023.	Plot No.-E-754, Focal point, Phase-VIII, Ludhiana-141 010, Punjab
6	Visakhapatnam, Andhra Pradesh, India	Manufacturing facility	30.01 (SEZ land)	Leased	The lease is valid with effect from November 1, 2007 to October 31, 2042.	Plot No. 47, APIIC, APSEZ, Pudimadaka Road, Opp: 11 KV Substation, Atchutapuram, Rambilli Mandalam, Visakhapatnam (A.P.)
7	B-208, Noida, Uttar Pradesh, India	Manufacturing facility	5.07	Leased	The lease is valid with effect from November 9, 1998 to November 8, 2088.	B-208/A1 & A2, Phase II, Noida - (U.P.) – 210 301
8	GFPL, Noida, Uttar Pradesh,		3.10 (SEZ land)	Leased	The lease is valid for a period of 15 years with effect from	142A/30-142A/51,

S. No.	Location	Use	Approximate Plot Size (in acres unless mentioned otherwise)	Nature of Right /Title	Lease Period	Addresses
	India				February 22, 2012	NSEZ, Noida - 201 305
9	Noida, Uttar Pradesh	Raw material storage space	0.96	Leased	The lease is valid with effect from October 25, 2017 to October 24, 2022.	B-33 and B-34, Sector-81, Noida-201 304, Uttar Pradesh
10	Noida, Uttar Pradesh	Distribution centre	1.24	Leased	The lease is valid with effect from. January 1, 2018 to December 31, 2025.	A-8, Sector-84, Noida-201304, Uttar Pradesh
11	Eldridge, Iowa, U.S.A., UOI	Manufacturing facility	9.52	Leased	The lease is valid with effect from March 28, 2002 to July 31, 2019.	1100, East Le Claire Road, Eldridge, IA 52748
		Warehousing facility	77,611 sq ft.of built up area		This lease is valid with effect from November 1, 2016 to July 31, 2019	
12	Augusta, Georgia, U.S.A.	Warehousing facility	6.20	Owned	-	1901, Willian Few Parkway, Horizon North Industrial Park, Grovetown, GA 30813, USA
13	Richmond County, Georgia, UUL	Warehousing facility	8.00	Leased	The lease is valid with effect from July 1, 2018 to June 30, 2023	1431 Marvin Griffin, Rd, Richmond County, Georgia
14	Hennef, Germany	Warehousing facility	2,063.68 sq. mts. of built up area	Leased	The lease is valid with effect from January 1, 2017 to December 31, 2018 automatically extendable for further one year	Reutherstraße 3, 53773 Hennef (Germany)
15	New Delhi, India	Office space (i.e., for our Registered Office)	400 sq. ft. of built up area	Leased	The lease is valid with effect from November 1, 2013 to October 31, 2021.	Gripwel House, Block-5, C-6 & 7 Vasant Kunj, New Delhi Delhi- 110 070
16	Noida, Uttar Pradesh, India	Office Space (i.e., for our Corporate Office)	9,900 sq. ft. of built up area	Leased	The lease is valid with effect from April 23, 2018 to April 22, 2021.	S.B. Towers, Ground Floor, Plot No. 1A/1, Sector -16A, Film City, Noida- 201 301

Other than the SEZ land in Visakhapatnam and Noida, as disclosed above, which is leased by us from the respective SEZ authorities, the premises in which our other facilities and offices are located are leased by us from persons including government entities and members of our Promoter Group.

## KEY REGULATIONS AND POLICIES IN INDIA

*The following description is a summary of the relevant sector specific regulations and policies applicable in India, as prescribed by the Government or state governments which are, basis the jurisdiction in which our projects are located, applicable to our Company and our Indian Subsidiaries and their respective business. The information detailed in this chapter has been obtained from publications available in the public domain and is based on the current provisions of Indian law and the judicial, regulatory and administrative interpretations thereof, which are subject to change or modification by subsequent legislative actions, regulatory, administrative, quasi-judicial, or judicial decisions. The description of the applicable laws and regulations set out below may not be exhaustive, and are only intended to provide general information to the investors and are neither designed nor intended to substitute for professional legal advice.*

### A. Environmental Laws

We are subject to various environment regulations as the operation of our establishments might have an impact on the environment in which they are situated. The basic purpose of the statutes listed below is to control, abate and prevent pollution. In order to achieve these objectives, pollution control boards (“PCBs”), which are vested with diverse powers to deal with water and air pollution, have been set up in each state. The PCBs are responsible for setting the standards for maintenance of clean air and water, directing the installation of pollution control devices in industries and undertaking inspections to ensure that industries are functioning in compliance with the standards prescribed. These authorities also have the power of search, seizure and investigation. All industries are required to obtain consent orders from the PCBs, which are indicative of the fact that the industry in question is functioning in compliance with the pollution control norms. These consent orders are required to be periodically renewed.

#### 1. *The Environment (Protection) Act, 1986 (“EPA”) and the Environment (Protection) Rules, 1986*

The EPA is an umbrella legislation designed to provide a framework for the Government to protect and improve the environment. The EPA vests with the Government, the power to take any measure it deems necessary or expedient for protecting and improving the quality of the environment, and preventing and controlling environmental pollution. This includes rules for the quality of environment, standards for emission of discharge of environment pollutants from various sources as provided under the Environment (Protection) Rules, 1986, inspection of any premises, plant, equipment, machinery, and examination of manufacturing processes and materials likely to cause pollution.

#### 2. *The Water (Prevention and Control of Pollution) Act, 1974 (“Water Act”)*

The Water Act aims to prevent and control water pollution by factories and manufacturing units and maintain and restore the quality and wholesomeness of water. Under the Water Act, any person establishing any industry, operation or process, any treatment or disposal system, use of any new or altered outlet for the discharge of sewage or new discharge of sewage, must obtain the consent of the relevant state PCB, which is empowered to establish standards and conditions that are required to be complied with.

#### 3. *The Air (Prevention and Control of Pollution) Act, 1981 (“Air Act”)*

The Air Act provides for the prevention, control and abatement of air pollution. Pursuant to the provisions of the Air Act, any person establishing or operating any industrial plant within an air pollution control area, must obtain the consent of the relevant state PCB prior to establishing or operating such industrial plant. The state PCB must decide on the application within a period of four months of receipt of such application. No person operating any industrial plant in any air pollution control area shall discharge or permit or cause to be discharged the emission of any air pollutant in excess of the standards laid down by the state PCB.

#### 4. *The Hazardous and Other Wastes (Management and Transboundary Movement) Rules, 2016 (“Hazardous Wastes Rules”)*

The Hazardous Wastes Rules aim to regulate the proper collection, reception, treatment, storage and disposal of hazardous waste. The Hazardous Wastes Rules impose an obligation on every occupier and operator of a facility generating hazardous waste to dispose of such waste without causing adverse effect on the environment, including through the proper collection, treatment, storage and disposal of such waste. Every occupier and operator of a facility generating hazardous waste must obtain an approval from the relevant PCB. The occupier, the transporter, the operator and the importer are liable for damages caused to the environment resulting from improper handling and disposal of hazardous waste. The operator and the occupier of a facility are liable for any fine that may be levied by the relevant state PCB.

#### 5. *The Public Liability Insurance Act, 1991 (“PLI Act”)*

The PLI Act imposes liability on the owner or controller of hazardous substances for any damage arising out of an accident involving such hazardous substances. The Government by way of a notification has enumerated a list of



hazardous substances. The owner or handler is also required to obtain an insurance policy insuring against liability to provide relief under the terms of the legislation. The rules made under the PLI Act mandate that the employer has to contribute towards the Environmental Relief Fund a sum equal to the premium paid on the insurance policies. The amount is payable to the insurer.

## **B. Labour Related Regulations**

The employment of workers, depending on the nature of activity, is regulated by a wide variety of generally applicable labour laws. The following is an indicative list of labour laws which may be applicable to our Company due to the nature of the business activities:

- (i) Contract Labour (Regulation and Abolition) Act, 1970;
- (ii) Employees' Provident Funds and Miscellaneous Provisions Act, 1952;
- (iii) The Factories Act, 1948;
- (iv) The Employees State Insurance Act, 1948;
- (v) Minimum Wages Act, 1948;
- (vi) Payment of Bonus Act, 1965;
- (vii) Payment of Gratuity Act, 1972;
- (viii) Payment of Wages Act, 1936;
- (ix) Maternity Benefit Act, 1961;
- (x) Industrial Disputes Act, 1947;
- (xi) Employees' Compensation Act, 1923;
- (xii) Inter-State Migrant Workmen (Regulation of Employment and Conditions of Service) Act, 1979; and
- (xiii) Various shops and establishments legislations, as applicable, in the states in which our establishments are set up.

## **C. Laws relating to Intellectual Property**

In India, patents, trademarks and copyrights enjoy protection under both statutory and common law. The key legislations governing intellectual property in India and which are applicable to our Company are the Patents Act, 1970, Copyright Act, 1957, the Designs Act, 2000 and the Trade Marks Act, 1999.

## **D. Other Laws**

### **1. *Special Economic Zones Act, 2005 ("SEZ Act") and the Special Economic Zone Rules, 2006 ("SEZ Rules")***

A SEZ is a specifically delineated duty free enclave, deemed to be a foreign territory for the purposes of trade as well as duties and tariffs. A board of approval has been set up under the SEZ Act, which is responsible for promoting the SEZ and ensuring its orderly development. The SEZ Rules prescribe the procedure for the operation and maintenance of a SEZ and for setting up and conducting business therein.

### **2. *Export Promotion Capital Goods Scheme ("EPCG Scheme")***

The objective of the EPCG Scheme under the Foreign Trade Policy 2015-20 is to promote the import of capital goods for producing quality goods and services in India, thereby enhancing India's manufacturing competitiveness. The EPCG Scheme allows import of capital goods for pre-production, production and post production at zero customs duty, subject to an export obligation equivalent to six times of duties, taxes and cess saved on capital goods, to be fulfilled in six years reckoned from date of issue of authorisation. The EPCG Scheme covers manufacturer exporters with or without supporting manufacturer(s)/ vendor(s), merchant exporters tied to supporting manufacturer(s) and service providers.

### **3. *Merchandise Exports from India Scheme ("MEIS")***

The objective of MEIS is to reward the exporters who offset infrastructural inefficiencies and associated costs involved in export of goods/ products, which are produced/ manufactured in India, especially those having high

export intensity, employment potential and thereby enhancing India's export competitiveness. Under the MEIS, the Government provides duty benefits depending on the product and the country of export.

## HISTORY AND CERTAIN CORPORATE MATTERS

### Brief History of our Company

Our Company was incorporated as “Uniparts India Limited” under the Companies Act, 1956 at Delhi, pursuant to a certificate of incorporation dated September 26, 1994 issued by the RoC. Our Company received a certificate of commencement of business on September 7, 1998 from the RoC.

### Changes in the Registered Office

Our registered office was originally located at 34, Regal Building, Parliament Street, New Delhi 110 001, India. Pursuant to a resolution of the Board dated December 6, 2002, the Registered Office was shifted from 34, Regal Building, Parliament Street to Gripwel House, Block 5, Sector C 6 & 7, Vasant Kunj, New Delhi 110 070, India with effect from December 6, 2002 for operational convenience.

### Major events in the history of our Company

The table below sets forth the key events in the history of our Company.

Calendar Year	Particulars
1994	Incorporation of our Company
2000	Commenced sales to domestic OEMs in agriculture sector in India and developed our 3PL OEM product vertical Established the first facility in Noida
2001	Commenced sales to John Deere in India
2002	Commenced sales to John Deere in Spain
2003	Commenced sales to John Deere in the USA
2004	Commenced sales to OEMs in Japan
2005	Consolidated various businesses into our Company including those of GFPL, Farmparts Company and SKG Incorporated UUL as a wholly owned subsidiary and acquired a majority stake in UOI Acquired a manufacturing and distribution facility in the USA, in Eldridge, Iowa Commenced sales to OEMs in the construction sector in the USA Set up a warehousing and distribution facility in Augusta, Georgia
2006	Commenced manufacturing products for the PMP vertical in India
2007	Acquired the balance equity stake in UOI Acquired 50% + 1 share equity interest in Kavee (a joint venture with Kramp), which owned 100% interest in Uniparts Kavee Services B.V Ashoka and Ambadevi made an equity investment in our Company Consolidated the business of Sweaty Spirit Apparel Limited (formerly known as Ace Tractor Parts Limited) into our Company Started manufacturing hydraulic cylinder components in one of the Noida facilities
2008	Commenced operations at the manufacturing facility located at Visakhapatnam, Andhra Pradesh GFPL became a wholly owned subsidiary of our Company
2010	Set up a warehousing and distribution facility in Hennef, Germany
2011	Started sales to the hydraulics market in USA from the manufacturing facility located at Visakhapatnam, Andhra Pradesh
2012	Commenced sale of components for the European construction OEM market
2013	Sold our entire equity interest in Kavee, with effect from April 1, 2012, to Kramp
2017	Added raw material storage space in Noida
2018	Commenced sales to Kobelco Added warehousing space at our facility in Augusta, USA Added additional distribution centre and office space in Noida

### Awards and Accreditations

The table below sets forth key awards and accreditations received by our Company and its Subsidiaries.

Calendar Year	Particulars
1998	UOI was awarded with (i) outstanding supplier performance; and (ii) recognition to the people of Olsen for their excellence in quality, teamwork and customer service, by Dubuque Works
2000	UOI was awarded with ‘10 Year Hall of Fame’ (1991 – 2000) by John Deere Davenport Works
2002	Our Company was awarded with ‘All India Certificate of Export Excellence’ in recognition of achieving highest exports during 2001–2002 amongst SSI units in the Agricultural Machinery Panel by Engineering Export Promotion Council GFPL was awarded with ‘All India Trophy for Highest Exporters’ in the category of capital goods exporters – SSI during 2001 – 2002 by Engineering Export Promotion Council
2003	Our Company was awarded with ‘All India Certificate of Export Excellence’ in recognition of achieving highest exports during 2002–2003 amongst SSI units in the Agricultural Machinery Panel by Engineering Export Promotion Council

Calendar Year	Particulars
2005	UOI was awarded with '15 Year Hall of Fame' (1991–2005) by John Deere
2007	Our Company was awarded with 'All India Award for Export Excellence' for special contribution for highest growth in exports as large enterprise by Engineering Export Promotion Council
2008	Our Company was awarded with a gold trophy for 'Top Exporter of the year' 2007-2008 by Engineering Export Promotion Council
2010	Recognition at JCB Annual Supplier Conference by JCB India Limited
2013	Our Company won the first prize at CII Kaizen Competition
2014	Our Company was awarded with 'Best Supplier Award' for overall performance by Tractors and Farm Equipment Limited Our Company was awarded with 'Kubota India GM Award'
2015	Our Company was ranked at 432 by the Fortune India Next 500 Our Company was awarded at the 6 <sup>th</sup> National Kaizen Competition with 'Special Category Award' for energy saving, poka yoke and environment by Chamber of Industrial and Commercial Undertaking
2016	Uniparts Group was awarded with 'Company with Great Managers' Trophy at the Great Manager Awards Our Company was awarded at the 7 <sup>th</sup> National Kaizen Competition with Special Kaizen Award by Chamber of Industrial and Commercial Undertaking
2017	Our Company was awarded with 'Innovative use of Training and Development as an HR Initiative for OD' by Global Training Development Leadership
2018	Our Company was awarded two awards at the 9 <sup>th</sup> National Kaizen Competition by Chamber of Industrial & Commercial Undertaking. Our Company was awarded with 'Special Trophy for Excellence in Exports of MEIS items 2015-20 Large Enterprise' by Engineering Export Promotion Council Our Company was awarded with 'Best Supplier Award' for outstanding contribution in co-creating value by TAFE Our Company was awarded with 'Excellence in Risk Mitigation' as runners up

### Time and cost overrun

In August 2005, a warehouse owned by UUL located in Augusta, Georgia collapsed during its construction. The building was thereafter re-constructed and operations were started in 2007. During this period, warehousing operations of UUL were carried out from a public warehouse. We incurred warehousing charges for use of the public warehouse as well as additional legal fees.

Except as aforementioned, our Company and our Subsidiaries have not experienced any significant time and cost overrun in relation to the setting up of our manufacturing facilities and warehouses. Such time/ cost overruns involve risks and uncertainties, including those discussed in *"Risk Factors – Activities involving our manufacturing process can be dangerous and can cause injury to people or property in certain circumstances. A significant disruption at any of our manufacturing facilities may adversely affect our production schedules, costs, sales and ability to meet customer demand"* on page 36.

### Defaults or re-scheduling of borrowings

For details pertaining to defaults by our Subsidiary, UOI, see *"Risk Factors - A failure to comply with financial and other restrictive covenants imposed on us under our financing agreements may cause us to default on these agreements, which may adversely affect our ability to conduct our business and operations."*

### Main Objects of our Company

The main objects contained in the Memorandum of Association of our Company are as follows:

- "1. To manufacture, sale and export of precision engineering products and allied engineering products.*
- 2. To manufacture, produce, roll, re-roll, cast, melt, forge, draw, mould, press, process, introduce, formulate, extend, test, research, weld, hire lease, meet out, repair, construct, assemble galvanize, head, temper, anneal, hard, machine, master, refine, associate, joint, improve exchange, polish, design, electroplate, import, export, supply, trade, stock, purchase, sell, and/or otherwise deal in any or all kinds of wrought iron, aluminium, copper, brass, zinc, iron, steel, nickel, lead, bronze, tin, chromium, cobalt, manganese, anodes, minerals, white and yellow metals and all other kinds of ferrous and non-ferrous metal in any form and/or kinds and/or shape including ingots, bars, solids, some, hollows, plates, sheets, scraps, dusts ashes, wastes seconds, defectives, liquids, poders, ores, minerals, and various type of cold and/or hot rolled and re-rolled sections, castings, mouldings, forgings, drawings, malleables, strips, coils, wires, balls, hardwares, metalwares, furnitures, boilers, machine tools, and accessories, tools, parts and equipments of automobiles, turbines, engines, machines and equipments.*
- 3. To act as exporters and importers and traders of any kinds of materials, commodities, goods and articles whether raw, semi manufactured or completely manufactured in India or abroad."*

### Amendments to our Memorandum of Association

The amendments to our Memorandum of Association in the last ten years of our Company are set out below.

<b>Date of shareholders' resolution</b>	<b>Details of the amendments</b>
September 10, 2013	Amendment to Clause V of the Memorandum of Association to reflect increase in authorised share capital from ₹ 250,000,000 divided into 25,000,000 Equity Shares of ₹ 10 each to ₹ 600,000,000 divided into 60,000,000 Equity Shares of ₹ 10 each.
November 27, 2018	Amendments to the Memorandum of Association for compliance with Companies Act, 2013

### **Holding company**

As on the date of this Draft Red Herring Prospectus, our Company has no holding company.

### **Subsidiaries**

As on the date of this Draft Red Herring Prospectus, our Company has four direct Subsidiaries and one indirect Subsidiary, details of which are provided below. GFPL, UUL, UEBV and UIG are our direct Subsidiaries. UOI, a wholly-owned subsidiary of UUL, is an indirect Subsidiary of our Company.

#### **1. Gripwel Fasteners Private Limited (“GFPL”)**

##### *Corporate Information*

GFPL was incorporated as Unilink Engineering Private Limited on January 13, 2005 under the Companies Act, 1956 pursuant to a certificate of incorporation issued by the RoC. The name was subsequently changed to Gripwel Fasteners Private Limited and a fresh certificate of incorporation pursuant to change of name was issued by the RoC on December 19, 2011. Its registered office is at Gripwel House, Block 5, LSC Sector C 6 & 7, Vasant Kunj, New Delhi 110 070, India.

##### *Nature of Business*

GFPL is engaged in the business of manufacturing, sale and export of 3PL, tractor attachment systems and other agricultural equipment components. GFPL is also engaged in servicing the after-market and OEM customers.

##### *Capital Structure*

The share capital pattern of GFPL is as follows:

<b>Authorised</b>	<b>Aggregate Nominal Value</b>
6,000,000 equity shares of ₹ 10 each	₹ 60,000,000
<b>Issued, subscribed and paid up</b>	
5,759,842 equity shares of ₹ 10 each	₹ 57,598,420

##### *Shareholding Pattern*

The shareholding pattern of GFPL is as follows:

<b>S. No.</b>	<b>Name of the shareholder</b>	<b>No. of equity shares of ₹ 10 each</b>	<b>Percentage of shareholding (%)</b>
1.	Uniparts India Limited	5,759,841	100.00
2.	Gurdeep Soni*	1	Negligible

\* As a nominee of our Company.

#### **2. Uniparts USA Limited (“UUL”)**

##### *Corporate Information*

UUL was incorporated on January 27, 2005 under the laws of the State of Delaware, USA. UUL's company registration is 3918054. Its registered office is at 251 Little Falls Drive, City of Wilmington, County of New Castle, Delaware 19808, USA.

##### *Nature of Business*

UUL is primarily engaged in the business of warehousing and providing services to its customers located in USA.

##### *Capital Structure*

The share capital pattern of UUL is as follows:

<b>Authorised</b>	<b>Aggregate Nominal Value</b>
300,000 common stock of USD 10 each	USD 3,000,000
800,000 convertible preferred stock of USD 10 each	USD 8,000,000
<b>Issued, subscribed and paid up</b>	
2,000 common stock of USD 10 each	USD 20,000
800,000 convertible preferred stock of USD 10 each	USD 8,000,000

#### *Shareholding Pattern*

The shareholding pattern of UUL is as follows:

<b>S. No.</b>	<b>Name of the shareholder</b>	<b>No. of shares of USD 10 each</b>	<b>Percentage of shareholding (%)</b>
<b>A.</b>	<b><i>Common Stock</i></b>		
	Uniparts India Limited	2,000	100
<b>B.</b>	<b><i>Convertible Preferred Stock</i></b>		
	Uniparts India Limited	800,000	100

### **3. Uniparts Europe B.V. (“UEBV”)**

#### *Corporate Information*

UEBV was incorporated on January 22, 2007 under the laws of Netherlands. Its registered office is at Herikerbergweg 238, Luna Arena, 1101 CM, Amsterdam, Netherlands.

#### *Nature of Business*

UEBV is currently not engaged in any activity, although it is authorised to do production, manufacturing, sale, marketing and export of heavy and light engineering products and allied engineering products.

#### *Capital Structure*

The share capital pattern of UEBV is as follows:

<b>Authorised</b>	<b>Aggregate Nominal Value</b>
1,500,000 shares of € 1 each	€ 1,500,000
<b>Issued, subscribed and paid up</b>	
1,100,000 shares of € 1 each	€ 1,100,000

#### *Shareholding Pattern*

The shareholding pattern of UEBV is as follows:

<b>S. No.</b>	<b>Name of the shareholder</b>	<b>No. of equity shares of € 1 each</b>	<b>Percentage of shareholding (%)</b>
1.	Uniparts India Limited	1,100,000	100

### **4. Uniparts India GmbH (“UIG”)**

#### *Corporate Information*

UIG was founded on May 18, 2010 under the laws of Germany with a capital stock of € 100,000 and incorporated on June 18, 2010 under the laws of Germany. It is registered in the commercial register of the Local Court Seigburg, Germany, under the registration number HRB 11078. Its registered office is at Reutherstraße, 3, 53773, Hennef, Germany.

#### *Nature of Business*

UIG is primarily engaged in the business of trade of machine components for mobile machines and general mechanical engineering.

#### *Capital Structure*

The share capital pattern of UIG is as follows:

<b>Authorised</b>	<b>Aggregate Nominal Value</b>
1 share of € 100,000 each	€ 100,000
<b>Issued, subscribed and paid up</b>	
1 share of € 100,000 each	€ 100,000

#### *Shareholding Pattern*

The shareholding pattern of UIG is as follows:

<b>S. No.</b>	<b>Name of the shareholder</b>	<b>No. of shares of € 100,000 each</b>	<b>Percentage of shareholding (%)</b>
1.	Uniparts India Limited	1	100

#### **5. Uniparts Olsen Inc. (“UOI”)**

##### *Corporate Information*

UOI was incorporated as ‘Olsen Engineering LP’ on April 22, 1998 under the laws of the State of Delaware, USA. Olsen Engineering LP was converted to ‘Olsen Engineering LLC’ on November 10, 2005 and then to ‘Uniparts Olsen Inc.’ on September 5, 2007. UUL acquired 50% plus one common stock ownership interest in UOI pursuant to the Investment-Cum-Unit Purchase Agreement dated November 11, 2005 between our Company, UUL, UOI, Kevin John Code, Dennis Francis DeDecker, Andrew Warren Code and James Norman Hallene. UOI became a wholly owned subsidiary of UUL on May 25, 2007 when UUL exercised its call option under the Investment-Cum-Unit Purchase Agreement. Its registered office is at Corp Trust Ctr. 1209, Orange Street, Wilmington, County of New Castle, Delaware 19801, USA.

##### *Nature of Business*

UOI is primarily engaged in the business of manufacturing and sale of all types of light engineering products and allied engineering products.

##### *Capital Structure*

The share capital pattern of UOI is as follows:

<b>Authorised</b>	<b>Aggregate Nominal Value</b>
1,224,301 common stock of USD 1 each	USD 1,224,301
<b>Issued, subscribed and paid up</b>	
1,224,301 common stock of USD 1 each	USD 1,224,301

#### *Shareholding Pattern*

The shareholding pattern of UOI is as follows:

<b>S. No.</b>	<b>Name of the shareholder</b>	<b>Number of shares of USD 1 each</b>	<b>Percentage of shareholding (%)</b>
1.	UUL	1,224,301	100

#### ***Other Confirmations***

There are no accumulated profits or losses of our Subsidiaries not accounted for by our Company.

#### **Details regarding material acquisitions or divestments of business or undertakings, mergers, amalgamations or revaluation of assets in the last ten years**

Except as stated below, our Company has not made any material acquisitions or divestments of any business or undertaking, and has not undertaken any mergers, amalgamation or revaluation of assets in the last ten years.

#### ***Disinvestment of Kavee***

Our Company entered into a share purchase and shareholders’ agreement dated January 22, 2007 with Kramp and Kavee pursuant to which Kramp sold all rights and title in 1,000,001 shares (constituting 50% +1 shares) of Kavee to Uniparts Europe B.V. for a total consideration of Euro 1,000,001. The agreement governed the rights and liabilities of the parties in connection with Kavee. In accordance with the agreement, the business affairs of Kavee as a joint venture were managed by a management board under the supervision of the supervisory board. Uniparts Europe B.V. and Kramp were each entitled to nominate two directors on the supervisory board, and one director each on the management board.

The parties to the share purchase and shareholders' agreement entered into a deed of cessation dated January 24, 2013, effective from April 1, 2012, pursuant to which the joint venture was cancelled and the share purchase and shareholders' agreement was terminated. Further, the 1,000,001 shares which Uniparts Europe B.V. had purchased pursuant to share purchase and shareholders' agreement dated January 22, 2007 were purchased back by Kramp for a total consideration of Euro 725,000. For further details relating to the loss incurred as a result of this transaction, see "*Risk Factors – If we are unable to successfully identify and integrate acquisitions, our growth strategy and prospects may be adversely affected*" on page 31.

## **Shareholders' Agreements and Other Agreements**

### ***Key terms of subsisting shareholders' agreements***

#### **SHA**

Our Company entered into a shareholders' agreement dated September 25, 2007 amongst our Promoters, Ambadevi and Ashoka ("**Shareholders' Agreement**"), as amended by agreements dated September 7, 2010 and February 18, 2013. Further, by a deed of accession dated May 31, 2012 and two separate deeds of accession, each dated July 4, 2012, Karan Soni and Meher Soni, respectively, became party to the Shareholders' Agreement. Further, a supplemental deed dated January 30, 2014 to the Shareholders' Agreement was entered into amongst our Promoters, Ambadevi, Ashoka, Karan Soni, Meher Soni and our Company (collectively, "**SHA Parties**"). The SHA was executed pursuant to the provisions of the investment agreement dated September 13, 2007 entered into amongst the Promoters, Ambadevi, Ashoka and our Company ("**Investment Agreement**"), in order to regulate the relationship between the shareholders of our Company and the way in which our Company shall be managed.

The SHA confers certain rights upon the Investor Selling Shareholders including, *inter alia*, (i) the right to appoint a nominee director; and (ii) certain reserved matters in the meetings held by the Board and Shareholders for which the Investor Selling Shareholders have affirmative voting rights. The SHA also provides for restrictions on transfer of Equity Shares by the shareholders of the Company.

The SHA has been amended by the amendment and termination agreement dated December 3, 2018 ("**Amendment and Termination Agreement**") amongst the SHA Parties, to *inter alia* provide for exceptions to certain rights available to the Investor Selling Shareholders which would otherwise have required consents and waivers to be obtained from Ashoka and Ambadevi in respect of undertaking the Offer ("**Amendment and Termination Agreement**"). Under the Amendment and Termination Agreement, the SHA shall immediately terminate without any further action by the parties with effect from the commencement of listing and trading of the Equity Shares on BSE and/ or NSE pursuant to the Offer.

The SHA Parties had also entered into a letter agreement dated September 22, 2014, which was terminated pursuant to the Amendment and Termination Agreement. Further, Ashoka, Ambadevi and the Promoters had entered into a letter agreement dated September 22, 2014, which was also terminated pursuant to the Amendment and Termination Agreement.

Notwithstanding the foregoing, in the event the Company is unable to complete the listing and trading of the Equity Shares on the Stock Exchanges on or before September 30, 2019 or any other date mutually agreed between the parties, the Amendment and Termination Agreement shall immediately terminate and the SHA shall immediately and automatically stand reinstated without any action by the parties.

#### ***Shareholders' Agreement among Olsen Investors and our Company***

Our Company entered into a shareholders' agreement dated May 25, 2007 with Kevin J. Code, Dennis F. DeDecker, Andrew Code, James Hallene, Mark Dawson, Melvin K. Gibbs, Marc C. Dorau, Bradley Miller, Walter J. Gruber, Mary L. Arp, Diana Craig, Wendy R. Hammen, Craig A. Johnson and Misty Marie Gracia (collectively, the "**Olsen Investors**") along with Gurdeep Soni and Paramjit Singh Soni. This shareholders' agreement governs the rights and obligations of such persons as shareholders in our Company. Any transfer of equity shares by the Olsen Investors is subject to a right of first refusal in favour of Gurdeep Soni and Paramjit Singh Soni, our Promoters. The Olsen Investor proposing to transfer its equity shares will be required to notify our Promoters with the details regarding the transfer ("**Transfer Notice**"), and each of our Promoters will have a right of first refusal to purchase, by himself or by a purchaser nominated by him, the pro rata share (based on his shareholding) of the equity shares being transferred. In the event a Promoter does not elect to purchase the equity shares, the other Promoter will have the right to purchase such equity shares. In the event our Promoters do not exercise the right of first refusal, the transferring shareholder may transfer all the equity shares to a third party purchaser on the terms and conditions as set out in the Transfer Notice. This shareholders' agreement will automatically terminate upon the completion of the IPO of our Company.

#### **Agreements with Key Managerial Personnel, Director, Promoter or any other employee**



There are no agreements entered into by a Key Managerial Personnel or Director or Promoter or any other employee of our Company, either by themselves or on behalf of any other person, with any shareholder or any other third party with regard to compensation or profit sharing in connection with dealings in the securities of our Company.

**Key terms of other subsisting material agreements**

Our Company has not entered into any other subsisting material agreements including with strategic partners, joint venture partners, and/or financial partners other than in the ordinary course of business of our Company.

## OUR MANAGEMENT

### Board of Directors

In terms of the Articles of Association, our Company is required to have not less than three Directors and not more than 15 Directors. As on date of this Draft Red Herring Prospectus, our Board comprises of eight Directors including three Executive Directors, one Nominee Director and four Independent Directors (including one woman Director).

The following table sets forth details regarding our Board as of the date of this Draft Red Herring Prospectus:

S. No.	Name, DIN, designation, term, period of directorship, address, occupation, date of birth and age	Other directorships
1.	<p>Gurdeep Soni</p> <p><b>DIN:</b> 00011478</p> <p><b>Designation:</b> Chairman and Managing Director</p> <p><b>Term:</b> Three years with effect from April 1, 2018, i.e. until March 31, 2021 and liable to retire by rotation</p> <p><b>Period of directorship:</b> Director since September 26, 1994</p> <p><b>Address:</b> Silveroak Estates, 142, Mall Road, Kishan Garh, Vasant Kunj, New Delhi 110 070, India</p> <p><b>Occupation:</b> Business</p> <p><b>Date of birth:</b> March 18, 1955</p> <p><b>Age:</b> 63 years</p>	<p><b>Indian Companies:</b></p> <ul style="list-style-type: none"> <li>• Amazing Estates Private Limited</li> <li>• Bluebells Homes Private Limited (formerly known as Oilintec Private Limited)</li> <li>• G K P Farms Private Limited</li> <li>• GFPL</li> <li>• SGA Trading Private Limited</li> <li>• Silveroak Estate Private Limited</li> <li>• SKG</li> <li>• Sweaty Spirit Apparel Limited (formerly known as Ace Tractor Parts Limited)</li> <li>• Tima Trading Private Limited</li> <li>• Uniparts Engineering Private Limited</li> <li>• Vivify Net Private Limited</li> </ul> <p><b>Foreign Companies:</b></p> <ul style="list-style-type: none"> <li>• UEBV</li> <li>• UOI</li> <li>• UUL</li> </ul>
2.	<p>Paramjit Singh Soni</p> <p><b>DIN:</b> 00011616</p> <p><b>Designation:</b> Executive Director</p> <p><b>Term:</b> Liable to retire by rotation</p> <p><b>Period of directorship:</b> Director since September 26, 1994</p> <p><b>Address:</b> 596, High Hampton, Dr. Martinez, GA 30907 9183, USA</p> <p><b>Occupation:</b> Business</p> <p><b>Date of birth:</b> October 9, 1960</p> <p><b>Age:</b> 58 years</p>	<p><b>Indian Companies:</b></p> <ul style="list-style-type: none"> <li>• Amazing Estates Private Limited</li> <li>• G K P Farms Private Limited</li> <li>• GFPL</li> <li>• SKG</li> <li>• Sweaty Spirit Apparel Limited (formerly known as Ace Tractor Parts Limited)</li> <li>• Tima Trading Private Limited</li> </ul> <p><b>Foreign Companies:</b></p> <ul style="list-style-type: none"> <li>• UEBV</li> </ul>

S. No.	Name, DIN, designation, term, period of directorship, address, occupation, date of birth and age	Other directorships
		<ul style="list-style-type: none"> <li>• UOI</li> <li>• UUL</li> </ul>
3.	<p>Herbert Coenen</p> <p><b>DIN:</b> 00916001</p> <p><b>Designation:</b> Executive Director</p> <p><b>Term:</b> Liable to retire by rotation</p> <p><b>Period of directorship:</b> Director since January 12, 2013</p> <p><b>Address:</b> Vinxeler Street, 74A, Koenigswinter, 53639, Germany</p> <p><b>Occupation:</b> Service</p> <p><b>Date of birth:</b> September 7, 1961</p> <p><b>Age:</b> 57 years</p>	<p><b>Indian Companies:</b></p> <p>Nil</p> <p><b>Foreign Companies:</b></p> <ul style="list-style-type: none"> <li>• UIG</li> <li>• UOI</li> </ul>
4.	<p>Ashish Kumar Agarwal*</p> <p><b>DIN:</b> 00139386</p> <p><b>Designation:</b> Nominee Director (nominee of Ambadevi and Ashoka)</p> <p><b>Term:</b> Not liable to retire by rotation</p> <p><b>Period of directorship:</b> Director since September 18, 2007</p> <p><b>Address:</b> B 402, Vivarea Tower, Sane Guruji Marg, Near Mahalaxmi Station, Jacob circle, Mumbai 400 011, India</p> <p><b>Occupation:</b> Service</p> <p><b>Date of birth:</b> March 6, 1972</p> <p><b>Age:</b> 46 years</p>	<p><b>Indian Companies:</b></p> <ul style="list-style-type: none"> <li>• GFPL</li> <li>• Infinity Alternatives Investment Managers Private Limited</li> </ul> <p><b>Foreign Companies:</b></p> <ul style="list-style-type: none"> <li>• UOI</li> <li>• UUL</li> </ul>
5.	<p>Alok Nagory</p> <p><b>DIN:</b> 00478140</p> <p><b>Designation:</b> Independent Director</p> <p><b>Term**:</b> Five years with effect from August 23, 2014, i.e. until August 22, 2019.</p> <p><b>Period of directorship:</b> Director since August 23, 2014</p> <p><b>Address:</b> 7/197, Swaroop Nagar, Kanpur 208 002, India</p> <p><b>Occupation:</b> Business</p> <p><b>Date of birth:</b> December 16, 1955</p> <p><b>Age:</b> 62 years</p>	<p><b>Indian Companies:</b></p> <ul style="list-style-type: none"> <li>• Diversified Engineering Corporation Private Limited</li> <li>• Merchant Chamber of Uttar Pradesh</li> <li>• Nagory Foster Private Limited</li> <li>• Nagory Investments Private Limited</li> <li>• The India Thermit Corporation Limited</li> <li>• Thermit Thormahlen India Limited</li> </ul>

S. No.	Name, DIN, designation, term, period of directorship, address, occupation, date of birth and age	Other directorships
6.	<p>M.R. Umarji</p> <p><b>DIN:</b> 00307435</p> <p><b>Designation:</b> Independent Director</p> <p><b>Term**:</b> With effect from August 4, 2014 till March 31, 2019.</p> <p><b>Period of directorship:</b> Director since January 7, 2014</p> <p><b>Address:</b> B-702, Pataliputra CHS, 4 Bungalows, Near Kamdhenu Department Store, Andheri (West), Mumbai 400 053, India</p> <p><b>Occupation:</b> Professional</p> <p><b>Date of birth:</b> November 5, 1941</p> <p><b>Age:</b> 77 years</p>	<p><b>Indian Companies:</b></p> <ul style="list-style-type: none"> <li>• Central Registry of Securitisation Asset Reconstruction and Security Interest of India</li> <li>• International Asset Reconstruction Company Private Limited</li> <li>• JM Financial Products Limited</li> <li>• Universal Trusteeship Services Limited</li> </ul>
7.	<p>Sharat Krishan Mathur</p> <p><b>DIN:</b> 01217742</p> <p><b>Designation:</b> Independent Director</p> <p><b>Term**:</b> With effect from August 4, 2014 till March 31, 2019.</p> <p><b>Period of directorship:</b> Director since November 29, 2013</p> <p><b>Address:</b> E-323/2, Greater Kailash – I, New Delhi 110 048, India</p> <p><b>Occupation:</b> Business</p> <p><b>Date of birth:</b> April 27, 1957</p> <p><b>Age:</b> 61 years</p>	<p><b>Indian Companies:</b></p> <ul style="list-style-type: none"> <li>• Altracaretech Private Limited</li> <li>• Contavide Enterprises Private Limited</li> <li>• GFPL</li> <li>• Insight Alpha Research &amp; Solutions Private Limited</li> </ul> <p><b>Foreign Companies:</b></p> <ul style="list-style-type: none"> <li>• UOI</li> </ul>
8.	<p>Shradha Suri</p> <p><b>DIN:</b> 00176902</p> <p><b>Designation:</b> Independent Director</p> <p><b>Term**:</b> Five years with effect from August 23, 2014, i.e. until August 22, 2019.</p> <p><b>Period of directorship:</b> Director since August 23, 2014</p> <p><b>Address:</b> N-101, Panchsheel Park, New Delhi 110 017, India</p> <p><b>Occupation:</b> Business</p> <p><b>Date of birth:</b> March 22, 1978</p> <p><b>Age:</b> 40 years</p>	<p><b>Indian Companies:</b></p> <ul style="list-style-type: none"> <li>• Asahi India Glass Limited</li> <li>• Automotive Component Manufacturers Association of India</li> <li>• DB Motors Private Limited</li> <li>• Denso Subros Thermal Engineering Centre India Limited</li> <li>• Fibcom India Limited</li> <li>• Globalydk Electric Private Limited</li> <li>• Mercantile Capital and Financial Services Private Limited</li> <li>• Prima Infratech Private Limited</li> </ul>

S. No.	Name, DIN, designation, term, period of directorship, address, occupation, date of birth and age	Other directorships
		<ul style="list-style-type: none"> <li>• Prima Telecom Limited</li> <li>• Prime Cellular Limited</li> <li>• Rohan Motors Limited</li> <li>• Subros Limited</li> </ul>

\* Upon listing and commencement of trading of the Equity Shares and simultaneous termination of the SHA, Ashish Kumar Agarwal will resign from our Board.

\*\* Pursuant to shareholders' resolution dated September 6, 2018 the term of our Independent Directors was extended for an additional period of five years.

### Relationship between our Directors

Except for Gurdeep Soni and Paramjit Singh Soni, who are brothers, none of our Directors are related to each other.

### Brief biographies of our Directors

**Gurdeep Soni** is the Chairman and Managing Director of our Company and has been associated with our Company since its incorporation. He was appointed as a Director of our Company on September 26, 1994. He holds a master's degree in management studies from the Birla Institute of Technology and Science, Pilani. He has 39 years of work experience including experience in different roles within the Uniparts Group. He has been actively involved in the day-to-day operations of our Company and is responsible for the after-market business of the Uniparts Group.

**Paramjit Singh Soni** is an Executive Director of our Company and has been associated with our Company since its incorporation. He was appointed as Director of our Company on September 26, 1994. He holds a bachelor's degree in commerce from the University of Delhi. He has 36 years of work experience including experience in different roles within the Uniparts Group and is presently based in the USA. He is responsible for the OEM business of the Uniparts Group and also actively involved in the formulation of corporate strategy and planning and concentrates on the inorganic growth and diversification plans of our Company.

**Herbert Coenen** is an Executive Director of our Company. He was appointed as a Director of our Company on January 12, 2013. He holds a diploma from the University of Applied Science, Cologne in mechanical engineering. He has 32 years of work experience, of which 20 years were with GKN Walterscheid GmbH. He is associated with the Uniparts Group since May, 2005 and has played a key role in business development, business expansion and technology adoption of our Company and its Subsidiaries outside India. He is also the managing director of our Subsidiary, Uniparts India GmbH.

**Ashish Kumar Agarwal** is a Nominee Director of our Company and is also on the board of our Subsidiaries GFPL, UOI and UUL. He was appointed as a Nominee Director on September 18, 2007. He holds a bachelor of technology degree in computer science and engineering from the Indian Institute of Technology, Delhi and a post graduate diploma in management from the Indian Institute of Management, Ahmedabad. He has over 23 years of experience in financial services, including 14 years of experience in private equity in PineBridge Investments, earlier known as AIG Investments, and 4 years of experience in investment management in Infinity Alternatives Advisors LLP. He was assistant vice president - corporate finance at Bank of America in Mumbai and then was the managing director of PineBridge Asia Partners II, LP, with responsibility over the Indian portfolio managed or advised by PineBridge Investments Asia Limited. Presently, he is the managing partner and chief executive officer of Infinity Alternatives Investment Managers Private Limited and also the managing partner of its group company, Infinity Alternatives Advisors LLP (together "Infinity Alternatives"), an India focussed asset management firm offering investment management/ advisory services to domestic and offshore clients.

**Alok Nagory** is an Independent Director of our Company. He was appointed as a Director of our Company on August 23, 2014. He holds a master's of science degree in biological sciences from the Birla Institute of Technology and Science, Pilani. He has about 40 years of experience in international business development, joint ventures and acquisitions in India Thermit Corporation Limited. He is currently the chairman and the managing director of The India Thermit Corporation Limited.

**M.R. Umarji** is an Independent Director of our Company. He was appointed as a Director of our Company on January 7, 2014. He holds a bachelor's and a master's degree in law from the University of Bombay. He has 53 years of work experience and has held executive positions in various government organizations and banks including as the executive director of the Department of Non-Banking Supervision of RBI, executive director of Corporation Bank and general manager of Dena Bank. He has been a member of certain committees and working groups set up by the Ministry of Finance, Government and the Reserve Bank of India. He is currently an independent legal consultant and was also a member of the Bankruptcy Law Reforms Committee.

**Sharat Krishan Mathur** is an Independent Director of our Company. He was appointed as a Director of our Company on November 29, 2013. He holds a bachelor's degree in engineering from the Birla Institute of Technology and Science, Pilani. He has over 33 years of experience in managing complex outsourcing, remote project management and process re-engineering. He has previously worked with reputed companies in different sectors such as Maclean Power Systems. He co-founded Insight Alpha in 2008, a primary research firm focused on finding relevant experts dedicated to providing institutional investors with access to leading industry professionals in India and South East Asia.

**Shradha Suri** is an Independent Director of our Company. She was appointed as a Director of our Company on August 23, 2014. She holds a master's degree in science from the London School of Economics and Political Science, University of London. She has over 18 years of experience and has played a key role in management of affairs, formulation and implementation of policies, directing strategy towards profitable growth and operations for Subros Limited. She is currently the managing director of Subros Limited, a part of the Suri Group, which has interests in a diverse range of businesses ranging from automotive components, cooling systems, hospitality, telecom and education.

### Confirmations

None of our Directors is, or was a director of any listed company during the last five years preceding the date of this Draft Red Herring Prospectus, whose shares have been, or were suspended from being traded on any of the stock exchanges during the term of their directorship in such company.

None of our Directors is, or was a director of any listed company which has been, or was delisted from any stock exchange during the term of their directorship in such company.

### Arrangement or understanding with major Shareholders, customers, suppliers or others

Except for Ashish Kumar Agarwal who was appointed as a Nominee Director pursuant to a shareholders' agreement dated September 25, 2007 between our Company, the Promoters and Ambadevi and Ashoka, there are no arrangements or understanding with major shareholders, customers, suppliers or others, pursuant to which any of the Directors were selected as a Director or member of the senior management. For further details, see “- *Shareholders' Agreements and Other Agreements*” page 141. Upon listing and commencement of trading of the Equity Shares and subsequent termination of the SHA, Ashish Kumar Agarwal will resign from our Board.

### Service contracts with Directors

Except for our Executive Directors who are entitled to statutory benefits upon termination of their employment from our Company or on retirement, no Director has entered into a service contract with our Company pursuant to which they are entitled to any benefits upon termination of employment. Herbert Coenen is entitled to non-compete fee upon termination of his employment from our Subsidiary, UIG. For further details see “- *Remuneration to Executive Directors*” on page 147.

### Details of Borrowing Powers

Subject to the provisions of the Companies Act, our Articles of Association authorise our Board, at its discretion, to generally secure the payment of any sum or sums of money for the purposes of our Company. Pursuant to a resolution passed by the shareholders of our Company at the EGM held on November 27, 2018, our Board has been authorised to borrow any sum or sums of monies in excess of our Company's aggregate paid-up capital and free reserves, provided that the total amount which may be so borrowed and outstanding shall not exceed a sum of ₹ 5,000 million for our Company alone and ₹ 7,000 million for our Company and its Subsidiaries taken together.

### Terms of appointment of our Directors

#### 1. Remuneration to Executive Directors:

Our Company has paid the following remuneration to our Executive Directors in Fiscal 2018:

S. No.	Name of Director	Total remuneration (in ₹ million)
1.	Gurdeep Soni	Nil
2.	Paramjit Singh Soni	Nil
3.	Herbert Coenen	Nil
	<b>Total</b>	Nil

#### Gurdeep Soni

Gurdeep Soni is the Chairman and Managing Director of our Company. He is not entitled to any remuneration from our Company and receives remuneration from our Subsidiary, GFPL. For further details, see “- *Remuneration from Subsidiaries*” on page 148.

### Paramjit Singh Soni

Paramjit Singh Soni is an Executive Director of our Company. He is not entitled to any remuneration from our Company and receives remuneration from our Subsidiary, UUL. For further details, see “- Remuneration from Subsidiaries” on page 148.

### Herbert Coenen

Herbert Coenen is an Executive Director of our Company. He is not entitled to any remuneration from our Company and receives remuneration from our Subsidiary, UIG. For further details, see “- Remuneration from Subsidiaries” on page 148.

## 2. Remuneration to Independent Directors:

The details of the sitting fees paid to the Independent Directors by our Company during Fiscal 2018 is as follows:

S. No.	Name of Director	Sitting fees paid (in ₹ million)	Commission paid (in ₹ million)
1.	Alok Nagory	-	-
2.	M.R. Umarji	0.32	1.10
3.	Sharat Krishan Mathur	0.31	-
4.	Shradha Suri	0.05	-
	<b>Total</b>	<b>0.68</b>	<b>1.10</b>

Each Independent Director is entitled to receive sitting fees of ₹ 50,000 per meeting for attending each meeting of our Board and ₹ 20,000 per meeting for attending each meeting of our committees, and commission pursuant to a resolution of the Board dated August 23, 2014 within the limits prescribed under the Companies Act, 2013. The travel expenses for attending meetings of the Board or a committee thereof, site visits and other Company related expenses are borne by our Company, from time to time.

## 3. Remuneration to Nominee Director

Our Nominee Director is not entitled to receive any remuneration from our Company and has not been paid any remuneration during Fiscal 2018.

### Remuneration from Subsidiaries

Except as disclosed below, none of our Directors have been paid any remuneration from our Subsidiaries, including contingent or deferred compensation accrued for the year during Fiscal 2018:

S. No.	Name of Director	Name of Subsidiary	Total remuneration (in ₹ million)
1.	Gurdeep Soni	GFPL	16.80
2.	Paramjit Singh Soni	UUL	33.84
3.	Herbert Coenen	UIG	19.55
4.	Sharat Krishan Mathur	GFPL	0.06

### Gurdeep Soni

Gurdeep Soni is entitled to remuneration from our Subsidiary, GFPL pursuant to an employment agreement between Gurdeep Soni and GFPL dated April 1, 2016 as amended on August 24, 2016 and March 28, 2017, resolution passed by its board of directors on March 23, 2018 and agreement dated November 10, 2018. Details of his employment are provided below:

Particulars	Remuneration
Salary	Maximum monthly salary of: (i) ₹ 1.40 million for Fiscal 2018 and from April 1, 2018 to September 30, 2018; (ii) ₹ 1.75 million from October 1, 2018 to March 31, 2019; and (iii) ₹ 1.92 million for Fiscal 2020.
Annual increment	Entitled to annual increment as per the India Inflation Linked Salary Increase in accordance with the performance management policy of GFPL.
Perquisites and benefits	Benefits such as medical expenses, personal accident insurance, club fees, conveyance facilities, communication facilities and reimbursement of expenses.
Bonus	Such sum as may be decided by the board of directors or a committee, based on performance of certain parameters as laid down by the board of directors or a committee of GFPL.

Particulars	Remuneration
Notice period	Six months, unless otherwise agreed by the board of GFPL.

### Paramjit Singh Soni

Paramjit Singh Soni is entitled to remuneration from our Subsidiary, UUL pursuant to an employment agreement between Paramjit Singh Soni and UUL dated August 27, 2014 as amended on May 30, 2016. Details of his employment are provided below:

Particulars	Remuneration
Salary	Monthly salary of: (i) USD 44,625 for Fiscal 2018; (ii) USD 45,500 for Fiscal 2019; (iii) USD 46,400 for Fiscal 2020; and (iv) USD 47,330 for Fiscal 2021.
Perquisites and benefits	Benefits such as medical expenses, personal accident insurance, club fees, conveyance facilities, communication facilities and reimbursement of expenses.
Bonus	Such sum as may be decided by the board of directors or a committee, based on performance of certain parameters as laid down by the board of directors or a committee of UUL.

### Herbert Coenen

Herbert Coenen is entitled to remuneration from our Subsidiary, UIG pursuant to an employment agreement between Herbert Coenen and UIG dated January 1, 2012 as amended by letter dated April 1, 2014 and November 20, 2015. Details of his employment are provided below:

Particulars	Remuneration
Salary	Annual salary of Euro 166,390 payable in equal monthly installments.
Perquisites and benefits	Performance linked incentive up to Euro 69,329, reimbursement of expenses, medical insurance and other insurances. Additionally, he is entitled to 50% of his annual salary and guaranteed bonus upon termination of his employment as non-compete fee for a period of one year.
Bonus	Guaranteed bonus of Euro 28,548 to be paid once a year on or before the closure of the next Fiscal.

### Bonus or profit sharing plan for the Directors

None of our Directors are entitled to any bonus or profit sharing plans of our Company.

### Shareholding of Directors in our Company

As per our Articles of Association, our Directors are not required to hold any qualification Equity Shares.

The shareholding of our Directors in our Company as on date of this Draft Red Herring Prospectus is set forth below:

Name of Director	Number of Equity Shares	Percentage shareholding (%)
Gurdeep Soni	14,955,570	33.14
Paramjit Singh Soni	6,595,090	14.61

### Interest of Directors

Except for Gurdeep Soni and Paramjit Singh Soni, none of our Directors have interest in any property acquired or proposed to be acquired, by our Company. For details of interest of Gurdeep Soni and Paramjit Singh Soni in property acquired by our Company, see “*Our Promoters and Promoter Group*” beginning on page 158.

Except for Gurdeep Soni and Paramjit Singh Soni, none of our Directors are interested in the promotion or formation of our Company as on date of this Draft Red Herring Prospectus. For details of interest of Gurdeep Soni and Paramjit Singh Soni in our Company, see “*Our Promoters and Promoter Group*” beginning on page 158.

No consideration in cash or shares or otherwise or in any other form has been paid or agreed to be paid to any of our Directors or to the firms or companies in which they are interested, by any person, either to induce such Director to become, or to help such Director to qualify as a Director, or otherwise for services rendered by him/ her or by the firm or company in which he/ she is interested, in connection with the promotion or formation of our Company.



All our Directors may be deemed to be interested to the extent of fees payable to them for attending meetings of our Board or a committee thereof, to the extent of other remuneration and reimbursement of expenses, if any, payable to them by our Company and its Subsidiaries under our Articles of Association and respective appointment letters, and to the extent of remuneration paid to them for services rendered as an officer or employee of our Company or our Subsidiaries. Our Directors may also be interested to the extent of Equity Shares, if any (together with dividends and other distributions in respect of such Equity Shares), held by them or held by the entities in which they are associated as promoters, directors, partners, proprietors or trustees or held by their relatives. Herbert Coenen may be deemed to be interested to the extent that he has been granted ESOPs pursuant to ESOP 2007. For further details, see “*Capital Structure*” beginning on page 64.

Our Company and our Subsidiary, GFPL have entered into separate lease agreements dated January 17, 2014 with Soni Holdings for lease of (i) certain portion of the building of our Registered Office; (ii) a certain portion of the building of the registered office of GFPL for a period of nine years with effect from November 1, 2013 and have paid a consolidated rent of ₹ 1.83 million in Fiscal 2018. Our Director, Gurdeep Soni is interested in the lease agreement by virtue of him being a partner in Soni Holdings. Further, except as stated in “*Financial Information*” and “*Our Promoters and Promoter Group*” beginning on pages 162 and 158, respectively, and to the extent of their shareholding in our Company, as disclosed, our Directors do not have any other interest in our business.

### Changes in the Board in the last three years

There have been no changes in our Board in the last three years.

### Corporate Governance

The provisions relating to corporate governance prescribed under the SEBI Listing Regulations will be applicable to us immediately upon listing of the Equity Shares on the Stock Exchanges. We are in compliance with the requirements of applicable regulations, including the SEBI Listing Regulations, the Companies Act and the SEBI ICDR Regulations, in respect of corporate governance including the constitution of our Board and committees thereof, and formulation and adoption of various policies.

Our Board has been constituted in compliance with the Companies Act and the SEBI Listing Regulations. The Board functions either as a full board, or through various committees constituted to oversee specific operational areas.

### Committees of the Board

#### *Audit Committee*

The Audit Committee of our Board consists of three members. The members of the Audit Committee are:

S. No.	Name and designation of Director	Committee designation
1.	Sharat Krishan Mathur (Independent Director)	Chairman
2.	M.R. Umarji (Independent Director)	Member
3.	Ashish Kumar Agarwal (Nominee Director)	Member

The Audit Committee was originally constituted pursuant to a resolution passed by our Board at its meeting held on April 1, 2005 and last re-constituted pursuant to a resolution passed by our Board at its meeting held on April 4, 2014. The scope and functions of the Audit Committee are in accordance with Section 177 of the Companies Act, 2013 and Regulation 18 of the SEBI Listing Regulations.

The terms of reference of the Audit Committee was amended in supersession to the previous terms of reference pursuant to a resolution passed by our Board at its meeting held on November 23, 2018 to include the following:

1. Oversight of the Company’s financial reporting process and the disclosure of its financial information to ensure that the financial statement is correct, sufficient and credible;
2. Recommendation for appointment, remuneration and terms of appointment of auditors of the Company;
3. Approval of payment to statutory auditors for any other services rendered by the statutory auditors;
4. Reviewing, with the management, performance of statutory and internal auditors, adequacy of the internal control systems;
5. Discussion with statutory auditors before the audit commences, about the nature and scope of audit as well as post-audit discussion to ascertain any area of concern;
6. Reviewing, with the management, the annual financial statements and auditor's report thereon before submission to the board for approval, with particular reference to:

- a) Matters required to be included in the Director's Responsibility Statement to be included in the Board's report, in terms of the Companies Act;
  - b) Changes, if any, in accounting policies and practices and reasons for the same;
  - c) Major accounting entries involving estimates based on the exercise of judgment by management;
  - d) Significant adjustments made in the financial statements arising out of audit findings;
  - e) Compliance with listing and other legal requirements relating to financial statements;
  - f) Disclosure of any related party transactions; and
  - g) Modified opinion(s) in the draft audit report.
7. Reviewing, with the management, the quarterly financial statements before submission to the board for approval;
  8. Laying down the criteria for granting omnibus approval in accordance with the Company's policy on related party transactions and such approval shall be applicable in respect of transactions which are repetitive in nature;
  9. Approval or any subsequent modification of transactions of the company with related parties;
  10. Examination of the financial statement and auditors' report thereon;
  11. Reviewing and monitoring, with the management, the statement of uses/application of funds raised through an issue (public issue, rights issue, preferential issue, etc.), the statement of funds utilized for purposes other than those stated in the offer document/prospectus/notice and the report submitted by the monitoring agency monitoring the utilisation of proceeds of a public or rights issue, and making appropriate recommendations to the Board to take up steps in this matter;
  12. Review and monitor the auditor's independence and performance, and effectiveness of audit process;
  13. Scrutiny of inter-corporate loans and investments;
  14. Valuation of undertakings or assets of the company, wherever it is necessary;
  15. Evaluation of internal financial controls and risk management systems;
  16. Reviewing the adequacy of internal audit function, if any, including the structure of the internal audit department, staffing and seniority of the official heading the department, reporting structure coverage and frequency of internal audit;
  17. Discussion with internal auditors of any significant findings and follow up there on;
  18. Reviewing the findings of any internal investigations by the internal auditors into matters where there is suspected fraud or irregularity or a failure of internal control systems of a material nature and reporting the matter to the Board;
  19. To look into the reasons for substantial defaults in the payment to the depositors, debenture holders, shareholders (in case of non-payment of declared dividends) and creditors;
  20. To review the functioning of the whistle blower mechanism;
  21. Approval of appointment of chief financial officer (i.e., the whole-time finance director or any other person heading the finance function or discharging that function) after assessing the qualifications, experience and background, etc. of the candidate;
  22. Carrying out any other function as may be required / mandated as per the provisions of the Companies Act, 2013, SEBI Listing Regulations and/or any other applicable laws;
  23. Reviewing the utilization of loans and/ or advances from investment by the holding company in the subsidiary exceeding ₹ 1,000 million or 10% of the asset size of the subsidiary, whichever is lower including existing loans / advances / investments.

Further, the Audit Committee shall mandatorily review the following information:

1. Management discussion and analysis of financial condition and results of operations;

2. Statement of significant related party transactions (as defined by the Audit Committee), submitted by management;
3. Management letters / letters of internal control weaknesses issued by the statutory auditors;
4. Internal audit reports relating to internal control weaknesses; and
5. The appointment, removal and terms of remuneration of the chief internal auditor shall be subject to review by the audit committee.
6. Statement of deviations:
  - (a) quarterly statement of deviation(s) including report of monitoring agency, if applicable, submitted to stock exchange(s) in terms of Regulation 32(1) of the SEBI Listing Regulations.
  - (b) annual statement of funds utilized for purposes other than those stated in the offer document/prospectus/notice in terms of Regulation 32(7) of the SEBI Listing Regulations.

The quorum of the Audit Committee shall be either two members or one third of the members of the Audit Committee whichever is greater, provided there shall be a minimum of two independent directors.

#### ***Nomination and Remuneration Committee***

The Nomination and Remuneration Committee of the Board consists of three members. The members of the Nomination and Remuneration Committee are:

<b>S. No</b>	<b>Name and designation of Director</b>	<b>Committee designation</b>
1.	M.R. Umarji (Independent Director)	Chairman
2.	Sharat Krishan Mathur (Independent Director)	Member
3.	Ashish Kumar Agarwal (Nominee Director)	Member

The Compensation Committee was constituted pursuant to a meeting of our Board held on January 8, 2007. The Compensation Committee has been renamed as the 'Nomination and Remuneration Committee' and was reconstituted by a meeting of our Board on April 4, 2014. The scope and functions of the Nomination and Remuneration Committee are in accordance with Section 178 of the Companies Act, 2013 and Regulation 19 of the SEBI Listing Regulations.

The terms of reference of the Nomination and Remuneration Committee was amended in supersession to the previous terms of reference pursuant to a resolution passed by our Board at its meeting held on November 23, 2018 to include the following:

1. Formulation of the criteria for determining qualifications, positive attributes and independence of a director and recommend to the Board of directors a policy, relating to the remuneration of the directors, key managerial personnel and other employees;
2. Formulation of criteria and manner for evaluation of performance of Board, its committees and individual directors to be carried out either by the Board, by the Nomination and Remuneration Committee or by an independent external agency and review its implementation and compliance;
3. Devising a policy on diversity of Board of Directors;
4. Identifying persons who are qualified to become directors and who may be appointed in senior management in accordance with the criteria laid down, and recommend to the Board of directors their appointment and removal;
5. Determining whether to extend or continue the term of appointment of the independent directors, on the basis of the report of performance evaluation of independent directors;
6. Recommending to the Board, all remuneration, in whatever form, payable to senior management;
7. To administer, monitor and formulate detailed terms and conditions of the Employees' Stock Option Scheme of the Company, inter-alia, including the following:
  - a) the quantum of option to be granted under the employees' stock option scheme per employee and in aggregate and the vesting of options;
  - b) the exercise price of the option granted;
  - c) the conditions under which option may vest in employee and may lapse in case of termination of employment for misconduct;

- d) the exercise period within which the employee should exercise the option and that option would lapse on failure to exercise the option within the exercise period;
  - e) the specified time period within which the employee shall exercise the vested option in the event of termination or resignation of an Employee;
  - f) the right of an employee to exercise all the options vested in him at one time or at various points of time within the exercise period;
  - g) re-pricing of the options which are not exercised, whether or not they have been vested if stock option rendered unattractive due to fall in the market price of the Shares;
  - h) the procedure for making a fair and reasonable adjustment to the number of options and to the exercise price in case of corporate actions such as rights issues, bonus issues, merger, sale of division and others. In this regard following shall be taken into consideration by the Nomination and Remuneration Committee:
    - the number and the price of stock option shall be adjusted in a manner such that total value of the option to the employee remains the same after the corporate action;
    - for this purpose global best practices in this area including the procedures followed by the derivative markets in India and abroad may be considered;
  - i) allow exercise of unvested options on such terms and conditions as it may deem fit;
  - j) the procedure for cashless exercise of options;
  - k) Forfeiture/ cancellation of options granted;
  - l) Framing of suitable policies and procedures to ensure that there is no violation of securities laws, as amended from time to time, by the ESOP trust, the Company and its employees, as applicable; and
  - m) All other issues incidental to the implementation of Employees' Stock Option Scheme.
8. To carry out any other function as is mandated by the Board from time to time and / or enforced / mandated by any statutory notification, amendment or modification, as may be applicable; and
  9. To perform such other functions as may be necessary or appropriate for the performance of its duties.

The quorum shall be either two members or one third of the members of the Nomination and Remuneration Committee whichever is greater, provided that there shall be minimum of one independent director.

#### ***Stakeholders' Relationship Committee***

The Stakeholders' Relationship Committee of the Board consists of three members. The members of the Stakeholders' Relationship Committee are:

<b>S. No</b>	<b>Name and designation of Director</b>	<b>Committee designation</b>
1.	Sharat Krishan Mathur (Independent Director)	Chairman
2.	Gurdeep Soni (Chairman and Managing Director)	Member
3.	Ashish Kumar Agarwal (Nominee Director)	Member

The Stakeholders' Relationship Committee was constituted by our Board at their meeting held on July 10, 2014. The scope and functions of the Stakeholders' Relationship Committee are in accordance with Section 178 of the Companies Act, 2013 and Regulation 20 of the SEBI Listing Regulations.

The terms of reference of the Stakeholders' Relationship Committee was amended in supersession to the previous terms of reference pursuant to a resolution passed by our Board at its meeting held on November 23, 2018 to include the following:

1. Resolving the grievances of the security holders of the Company including complaints related to transfer/transmission of shares, non-receipt of annual report, non-receipt of declared dividends, issue of new/duplicate certificates, general meetings etc.;
2. Review of measures taken for effective exercise of voting rights by the shareholder;
3. Review of adherence to the service standards adopted by the Company in respect of various services being rendered by the Registrar & Share Transfer Agent;

4. Review of the various measures and initiatives taken by the Company for reducing the quantum of unclaimed dividends and ensuring timely receipt of dividend warrants/annual reports/statutory notices by the shareholders of the Company;
5. Formulation of procedures in line with the statutory guidelines to ensure speedy disposal of various requests received from shareholders from time to time;
6. Redressal of shareholders' and investors' complaints/grievances such as transfer of shares, non-receipt of balance sheet, non-receipt of declared dividend etc.;
7. To approve, register, refuse to register transfer or transmission of shares and other securities;
8. To replace any share or other securities certificate(s) of the Company;
9. To authorise affixation of common seal of the Company;
10. To issue duplicate share or other security(ies) certificate(s) in lieu of the original share/security(ies) certificate(s) of the Company;
11. To dematerialize or rematerialize the issued shares;
12. Carrying out any other functions contained in the Companies Act, 2013 and/or equity listing agreements (if applicable), as and when amended from time to time; and
13. To further delegate all or any of the power to any other employee(s), officer(s), representative(s), consultant(s), professional(s), or agent(s).

The quorum for any meeting of the Stakeholders' Relationship Committee shall be two members.

#### ***Corporate Social Responsibility Committee***

The Corporate Social Responsibility Committee of our Board consists of three members. The members of the Corporate Social Responsibility Committee are:

<b>S. No</b>	<b>Name and designation of Director</b>	<b>Committee designation</b>
1.	Gurdeep Soni (Chairman and Managing Director)	Chairman
2.	Paramjit Singh Soni (Executive Director)	Member
3.	Sharat Krishan Mathur (Independent Director)	Member

The Corporate Social Responsibility Committee was constituted by our Board at their meeting held on April 4, 2014. The scope and functions of the Corporate Social Responsibility Committee are in accordance with Section 135 of the Companies Act, 2013. The terms of reference of the Corporate Social Responsibility Committee of our Company include:

1. Formulation of a corporate social responsibility policy to the Board, indicating the activities to be undertaken by the Company. The activities should be within the list of permitted activities specified in the Companies Act, 2013 and the rules thereunder;
2. Recommending the amount of expenditure to be incurred, amount to be at least 2% of the average net profit of the Company in the previous three years;
3. Instituting a transparent monitoring mechanism for implementation of the corporate social responsibility projects or programs or activities undertaken by the Company; and
4. Monitoring the corporate social responsibility policy from time to time.

The quorum for any meeting of the Corporate Social Responsibility Committee shall be two members.

Further, we have also constituted an IPO Committee and certain internal committees for the internal management of our Company.

**Management Organisation Chart**

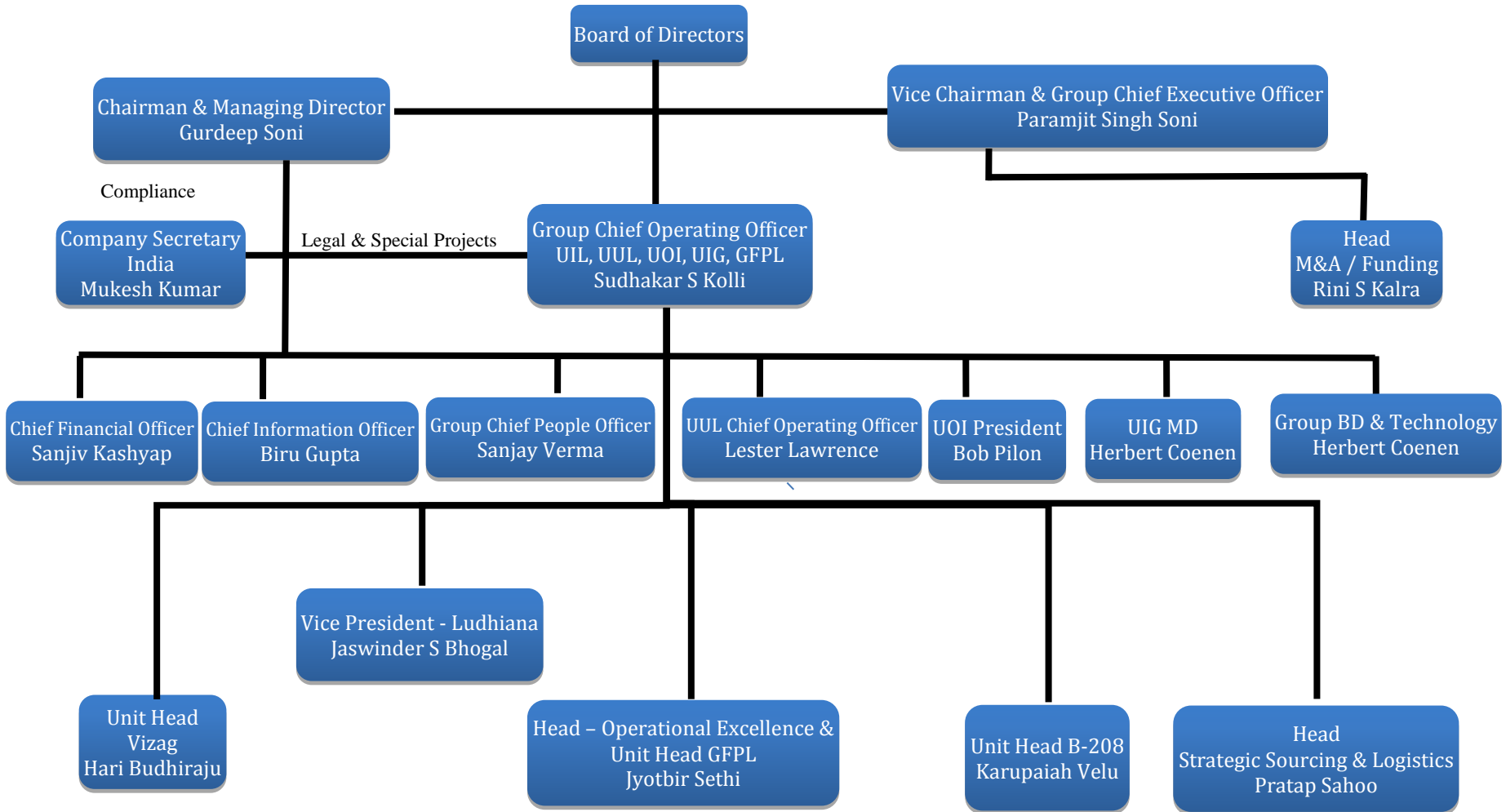

## Key Managerial Personnel

In addition to Gurdeep Soni, Paramjit Singh Soni and Herbert Coenen whose details are provided in “*Brief biographies of our Directors*” above, the details of our other Key Managerial Personnel in terms of the SEBI ICDR Regulations, as on the date of this Draft Red Herring Prospectus are set forth below:

**Sudhakar S Kolli** is the Group Chief Operating Officer of our Company. He holds a bachelor’s degree in mechanical engineering from Andhra University and a master’s degree in mechanical engineering from University of Bridgeport University, USA. He also holds a master’s degree in business administration from Millikin University, USA. He has 22 years of experience in the areas including general management with leadership role, operations and product development. Previously, he worked with Joy Technologies LLC, Joy Mining Machinery, CNH Industrial America LLC and Hyva Holding and spent over 13 years with Caterpillar, Inc. He joined our Company on February 8, 2016. He is responsible for strategic planning, business development and growth, management and organization building, reputation and brand building, operations, people management and other assignments or initiatives as mandated by our Board for improvement of our business performance. During Fiscal 2018, he received a remuneration of ₹ 15.53 million.

**Mukesh Kumar** is the Company Secretary, Compliance Officer and Associate Vice-President – Legal of our Company. He holds a bachelor’s degree in law from Magadh University, Bodhgaya. He is an associate of the Institute of Companies Secretaries of India. He has about 14 years of work experience in the legal and company secretarial field. Previously, he worked with companies such as NIIT Limited, Hero Motors Limited, PDS Multinational Group, Halonix Limited and Dhanuka Agritech Limited. He joined our company on January 19, 2016. He is responsible for all the legal and corporate secretarial functions of our Company. During Fiscal 2018, he received a remuneration of ₹ 4.69 million.

**Rini Kalra** is the Head of Merger and Acquisition/Funding of one of our Subsidiaries, GFPL. She has a bachelor’s degree in commerce from University of Bombay and a master’s degree in business administration from the University of Delhi. She has also completed the Chevening Gurukul Scholarship Programme in Leadership and Excellence from the London School of Economics and Political Science, London. She has 20 years of experience in corporate finance, and mergers and acquisitions. Previously, she has worked in leadership positions in companies such as Jubilant Oil & Gas Private Limited and American Orient Capital Partners India Private Limited. She joined us on April 1, 2012 for a fixed term of four years from April 1, 2012 till March 31, 2016 which has been further renewed up to May 30, 2019. She is responsible for the strategy, investor relations, mergers and acquisitions and fund raising activities of our Company. During Fiscal 2018, she received a remuneration of ₹ 13.71 million.

**Sanjiv Kashyap** is the Chief Financial Officer of our Company. He holds a bachelor’s degree in commerce from Punjab University, Chandigarh. He is an associate member of the ICAI and the Institute of Companies Secretaries of India. He has over 27 years of experience in various sectors including corporate finance, accounts, budgeting, taxation, company secretarial, risk management and human resources. He has previously worked with various companies in different sectors such as Halonix Limited, Whirlpool of India Limited, Lemnis Lighting India Private Limited and Lear Automotive India Private Limited. He joined our Company on June 1, 2012. He is responsible for overall leadership of the finance, accounts and taxation functions for the India operations of our Company. During Fiscal 2018, he received a remuneration of ₹ 9.48 million.

## Confirmations

Except for Gurdeep Soni and Paramjit Singh Soni who are brothers, none of the Key Managerial Personnel are related to each other or to the Directors of our Company.

There is no arrangement or understanding with the major Shareholders, customers, suppliers or others, pursuant to which any Key Managerial Personnel was selected as Key Managerial Personnel.

## Service Contracts with Key Managerial Personnel

None of the Key Managerial Personnel of our Company have entered into a service contract with our Company, pursuant to which they are entitled to any benefits upon termination of employment.

## Contingent and deferred compensation payable to our Director and Key Managerial Personnel

There is no contingent or deferred compensation payable to our Directors and Key Managerial Personnel, which does not form a part of their remuneration.

## Bonus or profit sharing plans of the Key Managerial Personnel

Except for Gurdeep Soni, Paramjit Singh Soni and Herbert Coenen, our Key Managerial Personnel are paid performance linked incentive pay based on the performance management policy of our Company dated April 1, 2014, which was further revised and became effective from April 1, 2015. Under this policy which is applicable to our Key Managerial Personnel

along with other employees of the Uniparts Group, the appraisal process covers three tier evaluation process consisting of (i) certain key performance indicators; (ii) self-appraisal; and (iii) performance review and rating. Except as stated above, our Company does not have bonus or profit sharing plan for the Key Managerial Personnel.

### Status of Key Managerial Personnel

Except for Paramjit Singh Soni, Herbert Coenen and Rini Kalra who are employees of our Subsidiaries, UUL, UIG and GFPL respectively, all the Key Managerial Personnel are permanent employees of our Company.

### Shareholding of Key Managerial Personnel

Except as set out below, none of our Key Managerial Personnel hold any Equity Shares in our Company. For details relating to shareholding of Gurdeep Soni and Paramjit Singh Soni, see “- *Shareholding of Directors in our Company*” on page 149.

Name of Key Managerial Personnel	Number of Equity Shares	Percentage shareholding (%)
Rini Kalra	10,436	0.02

### Changes in the Key Managerial Personnel

Other than as disclosed in “- *Changes in the Board in the last three years*” on page 150, the changes in the Key Managerial Personnel other than by way of retirement in the normal course in the preceding three years are as follows:

Name	Designation	Date of change	Reason for change
Mukesh Kumar	Associate Vice-President and Head –Legal and Secretarial	January 19, 2016	Appointment
Lalit Khanna	Company Secretary, Associate Vice-President - Legal and Compliance Officer	February 4, 2016	Resignation
Mukesh Kumar	Company Secretary, Associate Vice-President - Legal	February 5, 2016	Appointed as Company Secretary and re-designated as Company Secretary and Associate Vice-President - Legal
Sudhakar S Kolli	Group Chief Operating Officer	February 8, 2016	Appointment

### Interest of Key Managerial Personnel

Except for Rini Kalra, who is a Shareholder of our Company, none of our Key Managerial Personnel have any interest in our Company other than to the extent of the remuneration or benefits to which they are entitled to as per their terms of appointment and reimbursement of expenses incurred by them in the ordinary course of business and ESOPs held by them. The Key Managerial Personnel may also be deemed to be interested to the extent of any dividend payable to them and other distributions in respect of Equity Shares held by them in our Company, if any. For details relating to interest of Gurdeep Soni and Paramjit Singh Soni, who are also our Key Managerial Personnel, see “- *Interest of Directors*” on page 149. Under the ESOP 2007, the Key Managerial Personnel of our Company are also entitled to ESOPs and Equity Shares resulting from the exercise of options. For further details relating to ESOP 2007, see “*Capital Structure*” beginning on page 64.

### Employees Stock Options

Our Company has allotted Equity Shares to certain employees, including certain Key Managerial Personnel, under ESOP 2007, as amended from time to time. For details of the employee stock option scheme, see “*Capital Structure*” beginning on page 64.

### Payment or Benefit to Key Managerial Personnel

Except as stated in this section, no non-salary amount or benefit has been paid or given to any of our Company’s officers including Key Managerial Personnel within the two preceding years or is intended to be paid or given.



## OUR PROMOTERS AND PROMOTER GROUP

### Our Promoters

The Promoters of our Company are:

1. Gurdeep Soni; and
2. Paramjit Singh Soni.

As on the date of this Draft Red Herring Prospectus, our Promoters hold 21,550,660 Equity Shares in aggregate, representing 47.75% of the issued, subscribed and paid-up Equity Share capital of our Company.

**Details of our Promoters are as follows:**

#### 1. Gurdeep Soni

	<p>Gurdeep Soni, aged 63 years, is a resident Indian national. For further details, see “<i>Our Management</i>” beginning on page 143.</p> <p>The permanent account number of Gurdeep Soni is AAUPS8519C, aadhaar card number is 3839 8467 9808 and his driving license number is DL-1220020084384.</p>
---	---

#### 2. Paramjit Singh Soni

	<p>Paramjit Singh Soni, aged 58 years, is an overseas citizen of India. For further details, see “<i>Our Management</i>” beginning on page 143.</p> <p>The permanent account number of Paramjit Singh Soni is ABAPS1632H, aadhaar card number is 3651 9593 5874 and his driving license number (USA) is 055870566.</p>
--	--

Our Company confirms that the permanent account numbers, bank account numbers and passport numbers of Gurdeep Soni and Paramjit Singh Soni shall be submitted to the Stock Exchanges at the time of filing this Draft Red Herring Prospectus.

### Change in control of our Company

Our Promoters are the original promoters of our Company and there has not been any change in the control of our Company in the five years immediately preceding the date of this Draft Red Herring Prospectus.

### Interests of Promoters

Our Promoters are interested in our Company to the extent that they have promoted our Company and to the extent of their respective shareholding in our Company, their directorship in our Company and the dividends payable, if any, and any other distributions in respect of their respective shareholding in our Company or the shareholding of their relatives in our Company. For details of the shareholding of our Promoters in our Company, see “*Capital Structure*” beginning on page 64. For further details of interest of our Promoters in our Company, see “*Financial Information*” beginning on page 162.

Our Promoters may be deemed to be interested to the extent of remuneration, benefits and reimbursement of expenses payable to them as the Directors of our Company. For further details, see “*Our Management*” beginning on page 143.

Except for Gurdeep Soni and Paramjit Singh Soni who are Promoters and Directors of our Company, none of our Directors or Group Company have any interest in the promotion of our Company.

Except as stated below, our Promoters, Directors and Group Company have no interest, whether direct or indirect, in any property acquired by our Company within the preceding three years from the date of this Draft Red Herring Prospectus or proposed to be acquired by it as on the date of this Draft Red Herring Prospectus, or in any transaction by our Company for acquisition of land, construction of building or supply of machinery.

Our Company has, through its unit, SKG Engineering Co., acquired the land and buildings situated at C – 198, Phase – VII, Focal Point Industrial Area, Ludhiana from SKG vide an agreement to sell dated January 18, 2016 for an amount of ₹ 67.02 million. Our Promoters are interested in the aforementioned transaction for acquisition of property by virtue of their directorship in SKG. For information on our related party transactions, see “*Risk Factors*” and “*Financial Statements*” beginning on pages 21 and 162, respectively.

Our Promoters and Directors are not interested as a member of a firm or company, and no sum has been paid or agreed to be paid to our Promoters or to such firm or company in cash or shares or otherwise by any person either to induce such person to become, or qualify him as a Director or Promoter, or otherwise for services rendered by him or by such firm or company in connection with the promotion or formation of our Company.

Except to the extent of their directorship and shareholding in our Subsidiaries and Group Company, our Promoters do not have any interest in any venture that is involved in any activities similar to those conducted by our Company. For further details, see “*Our Management*” beginning on page 143 and “*History and Certain Corporate Matters*” beginning on page 136.

#### **Payment or Benefits to Promoters or Promoter Group**

Except as disclosed in this section and stated otherwise in “*Financial Information*” beginning on page 162 about the related party transactions entered into during the last three Fiscals and in “*Our Management*” beginning on page 143, there has been no payment or benefit to our Promoters or Promoter Group during the two years prior to the filing of this Draft Red Herring Prospectus nor is there any intention to pay or give any benefit to our Promoters or members of the Promoter Group as on the date of this Draft Red Herring Prospectus.

#### **Experience of our Promoter in the business of our Company**

For details in relation to experience of our Promoter in the business of our Company, see “*Our Management*” beginning on page 143.

#### **Disassociation by Promoters in the last three years**

Except for Gurdeep Soni, our Promoter, who disassociated as a designated partner from Charisma Homes LLP with effect from March 15, 2016, none of our Promoters have disassociated themselves from any company or firm during the preceding three years from the date of this Draft Red Herring Prospectus.

#### **Material Guarantees**

Except as stated in the “*Financial Indebtedness*” and “*Financial Information*” beginning on pages 238 and 162, respectively, our Promoters have not given any material guarantee to any third party with respect to the Equity Shares as on the date of this Draft Red Herring Prospectus.

#### **Promoter Group**

In addition to our Promoters, the individuals and entities that form a part of the Promoter Group of our Company in terms of Regulation 2(1)(pp) of the SEBI ICDR Regulations are set out below:

#### **Natural persons who are part of the Promoter Group**

The natural persons who are part of the Promoter Group (due to their relationship with our Promoters), other than our Promoters, are as follows:

1. Angad Soni;
2. Arjun Soni;
3. Harminder Chatha;
4. Jaswinder Singh Bhogal;
5. Karan Soni;
6. Meher Soni;
7. Navjit Bindra;
8. Neela Goolry;
9. Pamela Soni;
10. Santosh Kaur;
11. Sarabjit Soni;
12. Sonu Kapoor; and

13. Tanya Kohli.

**Entities forming part of the Promoter Group**

The entities forming part of our Promoter Group are as follows:

1. Amazing Estates Private Limited;
2. Avid Maintenance LLP;
3. Bluebells Homes Private Limited;
4. Charisma Homes LLP;
5. Diamante (Partnership Firm);
6. Farmparts Company (Partnership Firm);
7. G.K.P. Farms Private Limited;
8. Gripwel Fasteners (Partnership Firm);
9. Gurdeep Soni (HUF);
10. Indento International (Partnership Firm);
11. Leon India (Partnership Firm);
12. Paper Bag Entertainment Inc.;
13. Paramjit Singh (HUF);
14. P. Soni Family Trust;
15. Sepoy Beverages LLP;
16. SGA Trading Private Limited;
17. Silveroak Estates Private Limited;
18. SKG;
19. Soni Holdings (Partnership Firm);
20. Sweaty Spirit Apparel Limited;
21. The Karan Soni 2018 CG-NG Nevada Trust;
22. The Meher Soni 2018 CG-NG Nevada Trust;
23. The Paramjit Soni 2018 CG-NG Nevada Trust;
24. Tima Trading Private Limited;
25. Uniparts Engineering Private Limited; and
26. Vivify Net Private Limited.

## DIVIDEND POLICY

The declaration and payment of dividends will be recommended by our Board and approved by our Shareholders, at their discretion, subject to the provisions of our Articles of Association and the applicable law, including the Companies Act. The dividend, if any, will depend on a number of factors, including but not limited to the earnings, capital requirements, contractual obligations, applicable legal restrictions and overall financial position of our Company.

Our Company does not have a formal dividend policy. Any future determination as to the declaration of and payment of dividend will be based on the recommendation of our Board, and will depend on a number of factors, including but not limited to the earnings, capital requirements, contractual obligations, applicable legal restrictions and overall financial position of our Company.

In addition, our ability to pay dividends may be impacted by a number of other factors, including restrictive covenants under the loan or financing documents, our Company is currently a party to or may enter into from time to time. For more information on restrictive covenants under our loan agreements, see “*Financial Indebtedness*” beginning on page 238.

The dividend paid on the Equity Shares by our Company is set out in the following table:

Particular	From October 1, 2018 till the date of this Draft Red Herring Prospectus		From April 1, 2018 to September 30, 2018*		Fiscal 2018		Fiscal 2017		Fiscal 2016		
	Final	Interim	Final	Interim	Final	Interim	Final	Interim	Final	Interim	
Number of Equity Shares	-	-	45,133,758	-	-	-	-	-	-	-	45,133,758
Rate of dividend (%)	-	-	10	-	-	-	-	-	-	-	7.5
Amount of dividend (in ₹ million)	-	-	45.13	-	-	-	-	-	-	-	33.85
Mode of payment of dividend	-	-	Cash/ cheque/ RTGS	-	-	-	-	-	-	-	Cash/ cheque/ RTGS

\*Dividend has been paid for Fiscal 2018

## SECTION V: FINANCIAL INFORMATION

### FINANCIAL STATEMENTS

To  
The Board of Directors,  
Uniparts India Limited  
Gripwel House, Block 5, C 6&7,  
Vasant Kunj,  
New Delhi – 110 070

#### **Auditors' Report on Restated Consolidated Financial Information in connection with the Initial Public Offering ("IPO") of Uniparts India Limited (the "Company").**

Dear Sirs,

1. We have examined the attached Restated Consolidated Financial Statements of the Company and its subsidiaries (hereinafter together referred to as the "Group") which comprise the Restated Consolidated Statement of Assets and Liabilities as at September 30, 2018, March 31, 2018, March 31, 2017 and March 31, 2016, the Restated Consolidated Statement of Profit and Loss, Restated Consolidated Statement of Changes in Equity and the Restated Consolidated Statement of Cash Flow for the six months ended September 30, 2018 and years ended March 31, 2018, March 31, 2017 and March 31, 2016 and Significant Accounting Policies read together with the annexures and notes thereto and other restated consolidated financial information explained in paragraph 8 below (collectively, the "Restated Consolidated Financial Information") as approved by the Board of Directors at their meeting held on November 23, 2018 for the purpose of inclusion in the Draft Red Herring Prospectus ("DRHP") prepared by the Company in connection with its proposed IPO in terms of the requirements of :

- a. Section 26 of Part I of Chapter III of the Companies Act, 2013, as amended ("the Act") and,
- b. the Securities and Exchange Board of India (Issue of Capital and Disclosure Requirements) Regulations, 2018 in pursuance of provisions of Securities and Exchange Board of India Act, 1992 ("ICDR Regulations") read with SEBI Circular No. SEBI/HO/CFD/DIL/CIR/P/2016/47 dated March 31, 2016 on clarification regarding applicability of Indian Accounting Standards to disclosure in offer documents.

The preparation of the Restated Consolidated Financial Information is the responsibility of the management of the Company for the purpose set out in paragraph 11 below. The management's responsibility includes designing, implementing and maintaining adequate internal control relevant to the preparation and presentation of the Restated Consolidated Financial Information. The Management is also responsible for identifying and ensuring that the Company complies with the Companies Act and ICDR Regulations.

2. We have examined such Restated Consolidated Financial Information taking into consideration:
  - a. The terms of reference and terms of our engagement agreed upon with you in accordance with our engagement letter dated October 3, 2018 in connection with the proposed IPO; and
  - b. The Guidance Note on Reports in Company Prospectuses (Revised 2016) issued by the Institute of Chartered Accountants of India ("ICAI") ("The Guidance Note").
3. These Restated Consolidated Financial Information have been compiled by the Management from:
  - a. The audited consolidated financial statements of the Company as at and for the six months ended September 30, 2018, prepared in accordance with Special Purpose Audit and Indian Accounting Standards (Ind AS) prescribed under section 133 of the Companies Act, 2013 read with Companies (Indian Accounting Standards) Rules, 2015 and Companies (Indian Accounting Standards) (Amendment) Rules, 2016 and other relevant provisions of the Act, and on which we have expressed an unmodified audit opinion vide our report dated November 23, 2018 which have been approved by the Board of Directors at their Board meeting held on November 23, 2018.
  - b. The audited consolidated financial statements of the Company as at and for the year ended March 31, 2018 prepared in accordance with Companies (Accounting Standards) Rules, 2006, as amended, other accounting principles generally accepted in India ("Previous GAAP" or "IGAAP") and the other relevant provisions of the Act which has been approved by the Board of Directors at their Board meeting held on May 29, 2018. The audit for the financial year 2017-18 was conducted by us and these audited consolidated financial statements have been adjusted for the differences in the accounting principles adopted by the Company on transition to Ind AS, which have also been examined by us;

- c. The audited consolidated financial statements of the Company as at and for the year ended March 31, 2017, prepared in accordance with Companies (Accounting Standards) Rules, 2006, as amended, other accounting principles generally accepted in India (“Previous GAAP” or “IGAAP”) and the other relevant provisions of the Act which has been approved by the Board of Directors at their Board meeting held on June 15, 2017. These audited consolidated financial statements have been adjusted for the differences in the accounting principles adopted by the Company on transition to Ind AS which have been examined by us;
- d. Audit for the financial year 2016-17 was conducted by the previous auditor M/s S.C. Varma and Co., Chartered Accountants (Firm Registration Number: 000533N) and accordingly reliance has been placed on financial statements examined by them for the said year. The financial report included for the year is based solely on their report furnished to us by the Company;
- e. The audited consolidated financial statements of the Company as at and for the years ended March 31, 2016 prepared in accordance with Companies (Accounting Standards) Rules, 2006, as amended, other accounting principles generally accepted in India (“Previous GAAP” or “IGAAP”) and the other relevant provisions of the Act which has been approved by the Board of Directors at their Board meeting held on August 23, 2016. These audited Consolidated financial statements have been adjusted for the differences in the accounting principles adopted by the Company on transition to Ind AS, which have been examined by us;
- f. Audit for the financial year 2015-16 was conducted by the previous auditor M/s S. C. Varma and Co., Chartered Accountants (Firm Registration Number: 000533N) and accordingly reliance has been placed on financial statements examined by them for the said year. The financial report included for the year is based solely on their report furnished to us by the Company; and
- g. The Restated Consolidated Financial Information as at and for the years ended March 31, 2017 and March 31, 2016 are referred to as “the Proforma Ind AS Restated Consolidated Financial Information” as per the Guidance Note.
4. We did not audit the financial statements of subsidiaries/ step-down subsidiaries Uniparts USA Ltd., Uniparts Olsen Inc., Uniparts Europe B.V., Uniparts India GmbH, Gripwel Fasteners Private Limited as at September 30, 2018, March 31, 2018, March 31, 2017 and March 31, 2016, whose aggregate share of total assets, total revenues, and net cash flows and subsidiaries share of net profit/loss, included in the Restated Consolidated Financial Information, for the relevant years is tabulated below:

*(In ₹ million)*

Particulars	September 30, 2018	March 31, 2018	March 31, 2017	March 31, 2016
Total Assets*	5253.03	4338.14	3629.80	3884.39
Revenue*	3993.58	6356.50	4960.25	5714.74
Net Cash Inflows*	(-)10.18	26.26	10.92	14.77

\* Gross before giving consolidation adjustments.

These financial statements have been audited by other audit firms, as set out in Appendix I, whose reports have been furnished to us by the Company and our opinion in so far as it relates to the amounts included in these Restated Consolidated Financial Information are based solely on the report of other auditors.

5. In accordance with the requirements of Section 26 of Part I of Chapter III of the Companies Act, 2013 (“the Act”) read with ICDR Regulations and the Guidance Note, we report that:
- a. The Restated Consolidated Statement of Assets and Liabilities of the Company as at September 30, 2018, March 31, 2018, March 31, 2017 and March 31, 2016 examined by us, as set out in Annexure I to the Restated Consolidated Financial Information, have been arrived at after making adjustments and regrouping/reclassifications as in our opinion were appropriate and more fully described in Annexure VII: Statement on Adjustments to the Audited Consolidated Financial Statements.
- b. The Restated Consolidated Statement of Profit and Loss (including other comprehensive income) of the Company, for the six months ended September 30, 2018 and years ended March 31, 2018, March 31, 2017 and March 31, 2016 examined by us, as set out in Annexure II to the Restated Consolidated Financial Information, have been arrived at after making adjustments and regrouping/reclassifications as in our opinion were appropriate and more fully described in Annexure VII: Statement on Adjustments to the Audited Consolidated Financial Statements.
- c. The Restated Consolidated Statement of Cash Flow of the Company, for the six months ended September, 2018 and years ended March 31, 2018, March 31, 2017 and March 31, 2016 examined by us, as set out in Annexure III to the Restated Consolidated Financial Information, have been arrived at after making

adjustments and regrouping / reclassifications as in our opinion were appropriate and more fully described in Annexure VII: Statement on Adjustments to the Audited Consolidated Financial Statements.

- d. The Restated Consolidated Statement of Changes in Equity of the Company, for the six months ended September 30, 2018 and years ended March 31, 2018, March 31, 2017 and March 31, 2016 examined by us, as set out in Annexure IV to the Restated Consolidated Financial Information, have been arrived at after making adjustments and regrouping / reclassifications as in our opinion were appropriate and more fully described in Annexure VII: Statement on Adjustments to the Audited Consolidated Financial Statements.
6. Based on the above and according to the information and explanations given to us, and also as per the reliance placed on the financial statements audited by the previous auditors, M/s S.C. Varma and Co., Chartered Accountants for the years ended March 31, 2017 and March 31, 2016 (Firm Registration Number: 000533N) and their audit reports which have been furnished to us by the Company, we further report that the Restated Consolidated Financial Information:
- a. Have been made after incorporating adjustments for the changes in accounting policies retrospectively in respective financial years to reflect the same accounting treatment as per changed accounting policy for all the reporting six months;
  - b. Have been made after incorporating adjustments for the material amounts in the respective financial years to which they relate; and
  - c. Do not contain any extraordinary items that need to be disclosed separately in the Restated Consolidated Financial Information and do not contain any qualification requiring adjustments.
7. We have also examined the following restated consolidated financial information of the Company set out in the Annexure prepared by the management and approved by the Board of Directors on November 23, 2018 for the six months ended September 30, 2018 and years ended March 31, 2018, March 31, 2017 and March 31, 2016. In respect of the years ended March 31, 2017 and March 31, 2016, our examination was based upon the financial statements audited and reported by M/s S.C. Varma and Co., Chartered Accountants (Firm Registration Number : 000533N) and relied upon by us:
- a. Annexure V : Restated Consolidated Statement of Significant Accounting Policies;
  - b. Annexure VI : Notes to Restated Consolidated Financial Information;
  - c. Annexure VII : Statement on Adjustments to Audited Consolidated Financial Statements;
  - d. Annexure VIII : Restated Consolidated Statement of Accounting Ratios;
  - e. Annexure IX : Restated Consolidated Statement of Capitalization;
- According to the information and explanations given to us, and also as per the reliance placed on the reports submitted by the previous auditors M/s S. C. Varma and Co., Chartered Accountants(Firm Registration Number : 000533N), in our opinion, the Restated Consolidated Financial Information and the above restated financial information contained in Annexure VI to IX accompanying Restated Consolidated Financial Information, read with Restated Consolidated Statement of Significant Accounting Policies disclosed in Annexure V, are prepared after making adjustments and regroupings as considered appropriate and have been prepared in accordance with Section 26 of Part I of Chapter III of the Companies Act, 2013, ICDR Regulations and the Guidance Note.
8. Restated Consolidated Financial Information should not in any way be construed as a reissuance or re-dating of any of the previous audit reports issued by us or by other firms of Chartered Accountants, nor should Restated Consolidated Financial Information be construed as a new opinion on any of the audited consolidated financial statements referred to herein.
  9. We have no responsibility to update our report for events and circumstances occurring after the date of the report.
  10. Our report is intended solely for use of the management for inclusion in the offer document to be filed with Securities and Exchange Board of India, the stock exchanges where the equity shares are proposed to be listed and the Registrar of Companies, National Capital Territory of Delhi and Haryana, located at New Delhi, in connection with the proposed IPO of the Company. Our report should not be used, referred to or distributed for any other purpose except with our prior consent in writing.

For **Rakesh Banwari & Co.**  
Chartered Accountants  
Firm Registration No: 009732N

**Rakesh Aggarwal**  
Proprietor  
Membership Number: 088193

**Place:** New Delhi  
**Date:** November 23, 2018



**Appendix I referred in our Report on Restated Consolidated Financial Information in connection with the Initial Public Offering (“IPO”) of Uniparts India Limited**

<b>S. No.</b>	<b>Name of Subsidiary/ Step down subsidiary</b>	<b>Name of the auditor for the six months ended September 30, 2018</b>	<b>Name of the auditor for the financial year ended March 31, 2018</b>	<b>Name of the auditor for the financial year ended March 31, 2017</b>	<b>Name of the auditor for the financial year ended March 31, 2016</b>
1.	Uniparts USA Ltd	Withum Smith+Brown, PC	Withum Smith+Brown, PC	Withum Smith+Brown, PC	Withum Smith+Brown, PC
2.	Uniparts Olsen Inc.	Withum Smith+Brown, PC	Withum Smith+Brown, PC	Withum Smith+Brown, PC	Withum Smith+Brown, PC
3.	Uniparts Europe B. V.	Kroese Wevers Audit BV	Kroese Wevers Audit BV	Kroese Wevers Audit BV	Kroese Wevers Audit BV
4.	Uniparts India GmbH	DHPG DR. HARZEM & PARTNER mbB	DHPG DR. HARZEM & PARTNER mbB	DHPG DR. HARZEM & PARTNER mbB	DHPG DR. HARZEM & PARTNER mbB
5.	Gripwel Fasteners Private Limited	S. C Varma and Co., Chartered Accountants	S. C Varma and Co., Chartered Accountants	S. C Varma and Co., Chartered Accountants	S. C Varma and Co., Chartered Accountants

**UNIPARTS INDIA LIMITED**
**Annexure I : Restated Consolidated Statement of Assets and Liabilities**

(All amounts in millions of INR, unless stated otherwise)

Particulars	Note No.	As at September 30, 2018	As at March 31, 2018	As at March 31, 2017 Proforma Ind AS	As at March 31, 2016 Proforma Ind AS
<b>ASSETS</b>					
<b>I. Non-Current assets</b>					
(a) Property, plant and equipment	3	2,282.48	1,913.72	1,884.69	1,927.48
(b) Capital work-in-progress	3A	124.71	283.95	100.10	20.18
(c) Goodwill		604.90	584.82	597.35	598.33
(d) Other Intangible assets	4	17.66	17.77	21.16	30.49
(e) Intangible assets under development	4	24.93	21.60	18.01	4.48
(f) Financial assets					
(i) Loans	5	6.08	2.27	1.87	2.48
(ii) Other non-current financial assets	6	51.11	48.46	38.36	38.38
(g) Income Tax Assets (net)		71.61	96.40	82.68	138.00
(h) Other Non-Current Assets	7	44.50	54.73	27.36	11.49
<b>II. Current assets</b>					
(a) Inventories	8	3,784.95	3,041.80	2,273.54	2,287.21
(b) Financial assets					
(i) Trade receivables	9	1,453.67	1,156.99	1,008.25	983.03
(ii) Cash and cash equivalents	10	102.66	90.44	54.59	49.65
(iii) Bank Balances other than (ii) above	10	-	1.05	1.77	1.02
(iv) Derivative instruments	11	(65.72)	1.92	44.90	31.34
(v) Other current financial assets	6	0.61	0.63	0.52	0.62
(c) Other current assets	7	402.51	420.81	305.79	369.28
<b>Total assets</b>		<b>8,906.66</b>	<b>7,737.36</b>	<b>6,460.94</b>	<b>6,493.46</b>
<b>EQUITY AND LIABILITIES</b>					
(a) Equity share capital	12	446.20	446.20	446.20	446.20
(b) Other equity	13	3,438.31	3,198.90	2,732.33	2,495.78
<b>Total equity</b>		<b>3,884.51</b>	<b>3,645.10</b>	<b>3,178.53</b>	<b>2,941.98</b>
<b>Liabilities</b>					
<b>I. Non-current liabilities</b>					
(a) Financial liabilities					
(i) Borrowings	14	220.70	242.98	178.67	298.19
(b) Provisions	17	145.05	112.97	83.31	61.64
(c) Deferred tax liabilities (net)	16	259.36	248.50	288.46	269.38
(d) Other non-current liabilities	18	17.53	22.75	29.74	40.55
<b>II. Current liabilities</b>					
(a) Financial liabilities					
(i) Borrowings	14	2,791.63	2,103.56	1,629.10	1,872.09
(ii) Trade payables	19				
- Total outstanding dues to micro enterprises and small enterprises		6.25	-	-	-
- Total outstanding dues other than to micro enterprises and small enterprises		1,052.31	875.48	605.10	578.46
(iii) Other current financial liabilities (other than (c))	15	118.90	124.71	140.09	133.65
(b) Other current liabilities	18	338.87	292.33	265.34	206.29
(c) Provisions	17	50.98	55.33	51.37	45.61
(d) Current Tax Liabilities (net)		20.57	13.65	11.23	45.62
<b>Total liabilities</b>		<b>5,022.15</b>	<b>4,092.26</b>	<b>3,282.41</b>	<b>3,551.48</b>
<b>Total equity and liabilities</b>		<b>8,906.66</b>	<b>7,737.36</b>	<b>6,460.94</b>	<b>6,493.46</b>

The accompanying Restated Consolidated Statement of Significant Accounting Policies in Annexure V and Notes to Restated Consolidated Financial Information in Annexure VI are an integral part of this statement.

As per our report of even date attached

**For Rakesh Banwari & Co.**

Chartered Accountants

Firm Regn. No: 009732N

For and on behalf of the Board of Directors

**Uniparts India Limited**
**Gurdeep Soni**

[Chairman &amp; Managing Director]

[DIN: 00011478]

**Paramjit Singh Soni**

[Vice Chairman &amp; Director]

[DIN: 00011616]

**Rakesh Aggarwal**

Proprietor

Membership No.: 088193

Place: New Delhi

Date:

**Sanjiv Kashyap**

[Chief Financial Officer]

[ACA: 089203]

**Mukesh Kumar**

[Company Secretary]

[ACS: 17925]

UNIPARTS INDIA LIMITED  
Annexure II : Restated Consolidated Statement of Profit and Loss  
(All amounts in millions of INR, unless stated otherwise)

Particulars	Note No.	For the Period ended September 30, 2018	For the Year ended March 31, 2018	For the Year ended March 31, 2017 Proforma Ind AS	For the Year ended March 31, 2016 Proforma Ind AS
<b>Income</b>					
Revenue from operations	20	5,157.11	8,461.86	7,031.47	7,795.20
Other income	21	3.89	9.30	20.72	20.23
<b>Total income (i)</b>		<b>5,161.00</b>	<b>8,471.16</b>	<b>7,052.19</b>	<b>7,815.43</b>
<b>Expenses</b>					
Cost of raw materials and components consumed	22	2,176.41	3,369.36	2,389.33	2,813.98
Purchase of Stock-in-trade	23	-	-	1.37	3.03
Changes in Inventories	24	(616.83)	(548.01)	27.06	(52.59)
Excise duty on sale of goods		-	44.04	106.47	106.35
Employee benefits expense	25	1,053.55	1,769.58	1,581.81	1,595.76
Finance costs	26	70.22	90.32	86.55	100.48
Depreciation and amortisation expense	27	111.06	208.53	197.66	184.89
Other expenses	28	1,764.63	2,831.10	2,266.87	2,446.03
<b>Total expenses (ii)</b>		<b>4,559.04</b>	<b>7,764.92</b>	<b>6,657.12</b>	<b>7,197.93</b>
Profit before exceptional items and tax (i - ii)		<b>601.96</b>	<b>706.24</b>	<b>395.07</b>	<b>617.50</b>
Exceptional items gain/(loss)/prior period items		-	-	-	-
<b>Profit before tax</b>		<b>601.96</b>	<b>706.24</b>	<b>395.07</b>	<b>617.50</b>
Tax expense					
-For Current year		121.05	195.15	100.09	137.13
MAT credit		13.40	13.63	20.64	33.55
Deferred tax (Credit)/Charge		25.77	(37.88)	9.14	(0.29)
<b>Total tax expense</b>		<b>160.22</b>	<b>170.90</b>	<b>129.87</b>	<b>170.39</b>
<b>Profit for the period / year</b>		<b>441.74</b>	<b>535.33</b>	<b>265.20</b>	<b>447.12</b>
<b>Other comprehensive income</b>					
a) Other Comprehensive Income that will be reclassified to profit or loss in subsequent period					
- Net movement on cash flow hedges		(65.72)	1.92	44.90	31.34
- Exchange differences in translating the financial statements of foreign operations		(93.14)	(64.14)	1.80	(80.92)
- Income tax effect		(22.25)	0.67	15.38	10.69
		<b>(136.61)</b>	<b>(62.89)</b>	<b>31.32</b>	<b>(60.27)</b>
b) Other Comprehensive Income that will not be reclassified to profit or loss in subsequent period					
- Re-measurement gains / (losses) of defined benefit plans		(17.13)	(9.07)	(10.31)	(5.82)
- Income tax effect		(5.80)	(2.90)	(2.08)	(0.56)
		<b>(11.33)</b>	<b>(6.17)</b>	<b>(8.23)</b>	<b>(5.26)</b>
<b>Other comprehensive income for the period / year (a+b)</b>		<b>(147.94)</b>	<b>(69.06)</b>	<b>23.08</b>	<b>(65.53)</b>
<b>Total comprehensive income for the period / year</b>		<b>293.80</b>	<b>466.27</b>	<b>288.28</b>	<b>381.59</b>
<b>Profit is attributable to:</b>					
Owners of the Company		441.74	535.33	265.20	447.12
Non-controlling interest		-	-	-	-
		<b>441.74</b>	<b>535.33</b>	<b>265.20</b>	<b>447.12</b>
<b>Other comprehensive income is attributable to:</b>					
Owners of the Company		(147.94)	(69.06)	23.08	(65.53)
Non-controlling interest		-	-	-	-
		<b>(147.94)</b>	<b>(69.06)</b>	<b>23.08</b>	<b>(65.53)</b>
<b>Total comprehensive income is attributable to:</b>					
Owners of the Company		293.80	466.27	288.28	381.59
Non-controlling interest		-	-	-	-
		<b>293.80</b>	<b>466.27</b>	<b>288.28</b>	<b>381.59</b>
<b>Earnings per Equity Share</b>					
Basic (Amount in INR)	29	10.02	12.14	6.01	10.14
Diluted (Amount in INR)		9.79	11.86	5.88	9.91

The accompanying Restated Consolidated Statement of Significant Accounting Policies in Annexure V and Notes to Restated Consolidated Financial Information in Annexure VI are an integral part of this statement.

As per our report of even date attached

**For Rakesh Banwari & Co.**

Chartered Accountants  
Firm Regn. No: 009732N

**Rakesh Aggarwal**

Proprietor  
Membership No.: 088193  
Place: New Delhi  
Date:

For and on behalf of the Board of Directors

**Uniparts India Limited**

**Gurdeep Soni**  
[Chairman & Managing Director]  
[DIN: 00011478]

**Paramjit Singh Soni**  
[Vice Chairman & Director]  
[DIN: 00011616]

**Sanjiv Kashyap**  
[Chief Financial Officer]  
[ACA: 089203]

**Mukesh Kumar**  
[Company Secretary]  
[ACS: 17925]

**UNIPARTS INDIA LIMITED**
**Annexure III : Restated Consolidated Statement of Cash Flow**

(All amounts in millions of INR, unless stated otherwise)

Particulars	For the Period ended September 30, 2018	For the Year ended March 31, 2018	For the Year ended March 31, 2017 Proforma Ind AS	For the Year ended March 31, 2016 Proforma Ind AS
<b>A: CASH FLOW FROM OPERATING ACTIVITIES:</b>				
<b>Profit before tax</b>	<b>601.96</b>	<b>706.24</b>	<b>395.07</b>	<b>617.50</b>
<b>Adjustments to reconcile profit before tax to net cash flows</b>				
- Depreciation and amortization on continuing operations	111.06	208.53	197.66	184.89
- Share issue expenses written off	-	-	(52.51)	-
- Deferred Tax	13.14	0.15	(3.36)	8.32
- Employee Benefits Expense	0.02	0.29	0.77	1.49
- Loss/(profit) on sale of fixed assets	0.56	(2.09)	4.06	1.00
- Interest Expenses	59.08	72.60	71.80	85.89
- Profit on sale of Investments	-	-	(0.13)	-
- Effects of Consolidation	(134.91)	(55.16)	8.48	(97.16)
- Interest Income	(1.75)	(1.88)	(4.58)	(8.44)
<b>Operating profit before working capital changes</b>	<b>649.16</b>	<b>928.67</b>	<b>617.26</b>	<b>793.49</b>
<b>Movement in working capital :</b>				
Increase/(decrease) in trade payable	183.08	270.38	26.64	(32.87)
Increase/(decrease) in current provisions	(4.35)	3.96	5.76	3.66
Increase/(decrease) in non-current provisions	14.95	20.59	11.36	5.81
Increase/(decrease) in other current liabilities other than Deferred Government Grant	(5.07)	(11.28)	(10.82)	(5.83)
Increase/(decrease) in Deferred Government Grant	(0.15)	4.29	-	-
Increase/(decrease) in other current liabilities	79.18	(12.31)	54.88	4.75
Increase/(decrease) in current tax liabilities	6.93	2.43	(34.39)	44.58
Increase/(decrease) in other current financial liabilities	(5.82)	(15.38)	6.44	(5.30)
Decrease/(increase) in trade receivables	(296.68)	(148.74)	(25.24)	(64.75)
Decrease/(increase) in derivative instruments	1.92	44.90	31.34	17.15
Decrease/(increase) in inventories	(743.15)	(768.26)	13.67	(53.43)
Decrease/(increase) in other current assets	18.30	(115.02)	63.50	(94.41)
Decrease/(increase) in other current financial assets	0.02	(0.12)	0.11	0.03
Decrease/(increase) in other non-current assets	10.23	(27.37)	(15.87)	7.62
Decrease/(increase) in Income Tax Assets	24.79	(13.72)	55.32	46.00
Decrease/(increase) in non-current loans	(3.81)	(0.40)	0.61	1.65
Decrease/(increase) in other non-current financial assets	(2.65)	(10.10)	0.02	(6.49)
<b>Cash generated from/(used in) operations</b>	<b>(73.12)</b>	<b>152.52</b>	<b>800.59</b>	<b>661.66</b>
Direct taxes paid (net of refunds)	(134.45)	(208.78)	(120.73)	(184.08)
<b>Net cash flow from/ (used in) operating activities</b>	<b>(207.57)</b>	<b>(56.26)</b>	<b>679.86</b>	<b>477.58</b>
<b>B: CASH FLOW FROM INVESTING ACTIVITIES</b>				
(Purchase)/ sale of property, plant and Equipment; including intangible assets, CWIP and capital advances	(305.86)	(426.30)	(252.22)	(406.95)
Proceeds from sale of property, plant & equipment	4.09	7.82	4.83	4.39
Interest income	1.75	1.89	4.58	8.44
Profit on sale of investments	-	-	0.13	-
<b>Net cash flow from/ (used in) investing activities</b>	<b>(300.02)</b>	<b>(416.59)</b>	<b>(242.68)</b>	<b>(394.13)</b>
<b>C: CASH FLOW FROM FINANCING ACTIVITIES</b>				
Proceeds/(Repayment) of long-term borrowings	(22.28)	64.30	(119.51)	(17.16)
Current borrowings repayments (net)	688.07	474.46	(242.99)	167.79
Dividends Paid (including dividend distribution tax)	(54.41)	-	-	(40.93)
Interest paid	(59.08)	(72.60)	(71.80)	(85.89)
<b>Net cash flow from/ (used in) financing activities</b>	<b>552.30</b>	<b>466.16</b>	<b>(434.30)</b>	<b>23.81</b>
<b>Net Increase/(Decrease) in Cash and Cash Equivalents</b>	<b>44.71</b>	<b>(6.69)</b>	<b>2.88</b>	<b>107.26</b>
Cash and cash equivalent balance at the beginning of the year	91.49	56.36	50.67	36.09
Net Increase/(Decrease) in Temporary Overdraft	(32.64)	39.29	4.17	(94.64)
Effects of exchange difference on cash and cash equivalent held in foreign currency	(0.90)	2.53	(1.36)	1.95
<b>Cash and cash equivalent balance at the end of the period/year [refer note 10]</b>	<b>102.66</b>	<b>91.49</b>	<b>56.36</b>	<b>50.67</b>

**UNIPARTS INDIA LIMITED****Annexure III : Restated Consolidated Statement of Cash Flow**

(All amounts in millions of INR, unless stated otherwise)

**Cash and Cash equivalents for the purpose of cash flow statement**

Particulars	For the Period ended September 30, 2018	For the Year ended March 31, 2018	For the Year ended March 31, 2017 Proforma Ind AS	For the Year ended March 31, 2016 Proforma Ind AS
<b>Balances with banks:</b>				
In cash credit and current accounts	96.42	87.25	52.37	47.09
In EEFC accounts	3.08	0.00	0.00	0.43
In other bank balances	-	1.05	1.77	1.02
Cash on hand	3.16	3.19	2.22	2.13
<b>Total</b>	<b>102.66</b>	<b>91.49</b>	<b>56.36</b>	<b>50.67</b>

*The accompanying Restated Consolidated Statement of Significant Accounting Policies in Annexure V and Notes to Restated Consolidated Financial Information in Annexure VI are an integral part of this statement.*

As per our report of even date attached

**For Rakesh Banwari & Co.**

Chartered Accountants

Firm Regn. No: 009732N

For and on behalf of the Board of Directors

**Uniparts India Limited****Rakesh Aggarwal**

Proprietor

Membership No.: 088193

Place: New Delhi

Date:

**Gurdeep Soni**

[Chairman &amp; Managing Director]

[DIN: 00011478]

**Paramjit Singh Soni**

[Vice Chairman &amp; Director]

[DIN: 00011616]

**Sanjiv Kashyap**

[Chief Financial Officer]

[ACA: 089203]

**Mukesh Kumar**

[Company Secretary]

[ACS: 17925]

**UNIPARTS INDIA LIMITED**
**Annexure IV: Restated Consolidated Statement of Changes in Equity**  
 (All amounts in millions of INR, unless stated otherwise)

**A. Equity share capital**
**Equity shares of INR 10/- each issued, subscribed and fully paid**

Particulars	No.	Amount
As at April 1, 2015 - Proforma Ind AS	45,133,758	451.34
As at March 31, 2016 - Proforma Ind AS	45,133,758	451.34
As at March 31, 2017 - Proforma Ind AS	45,133,758	451.34
As at March 31, 2018	45,133,758	451.34
As at September 30, 2018	45,133,758	451.34

**B. Other equity**

Particulars	Attributable to Equity Share holders of the Parent						Total
	Reserves and Surplus				Items of OCI		
	Security Premium	General Reserve	Retained Earnings	Shares Options Outstanding Account	Cash Flow hedge Reserve	Exchange differences on translating the financial statements of foreign operations	
<b>Balance as at April 1, 2018</b>	<b>865.74</b>	<b>(40.45)</b>	<b>3,006.99</b>	<b>28.15</b>	<b>51.43</b>	<b>(636.51)</b>	<b>3,275.34</b>
- Profit for the year	-	-	441.74	-	-	-	441.74
Remeasurement of defined benefit obligation (net of tax)	-	-	(11.33)	-	-	-	(11.33)
Amount recognised during the year	-	-	-	0.02	-	(93.14)	(93.12)
Effective portion of gain and losses on designated portion of hedging instruments in a cash flow hedge (net of tax)	-	-	-	-	(43.47)	-	(43.47)
Dividend	-	-	(54.41)	-	-	-	(54.41)
<b>Subtotal at September 30, 2018</b>	<b>865.74</b>	<b>(40.45)</b>	<b>3,382.99</b>	<b>28.17</b>	<b>7.96</b>	<b>(729.65)</b>	<b>3,514.75</b>
Less: Amount recoverable from Uniparts Employees Stock option	76.44	-	-	-	-	-	76.44
<b>At September 30, 2018</b>	<b>789.30</b>	<b>(40.45)</b>	<b>3,382.99</b>	<b>28.17</b>	<b>7.96</b>	<b>(729.65)</b>	<b>3,438.31</b>
<b>Balance as at April 1, 2017</b>	<b>865.74</b>	<b>(40.45)</b>	<b>2,477.83</b>	<b>27.86</b>	<b>50.17</b>	<b>(572.37)</b>	<b>2,808.77</b>
- Profit for the year	-	-	535.33	-	-	-	535.33
Remeasurement of defined benefit obligation (net of tax)	-	-	(6.17)	-	-	-	(6.17)
Amount recognised during the year	-	-	-	0.29	-	(64.14)	(63.85)
Effective portion of gain and losses on designated portion of hedging instruments in a cash flow hedge (net of tax)	-	-	-	-	1.26	-	1.26
<b>Subtotal at March 31, 2018</b>	<b>865.74</b>	<b>(40.45)</b>	<b>3,006.99</b>	<b>28.15</b>	<b>51.43</b>	<b>(636.51)</b>	<b>3,275.34</b>
Less: Amount recoverable from Uniparts Employees Stock option	76.44	-	-	-	-	-	76.44
<b>At March 31, 2018</b>	<b>789.30</b>	<b>(40.45)</b>	<b>3,006.99</b>	<b>28.15</b>	<b>51.43</b>	<b>(636.51)</b>	<b>3,198.90</b>
<b>Balance as at April 1, 2016-Proforma Ind AS</b>	<b>865.74</b>	<b>12.05</b>	<b>2,220.86</b>	<b>27.09</b>	<b>20.65</b>	<b>(574.17)</b>	<b>2,572.21</b>
- Profit for the year	-	-	265.20	-	-	-	265.20
Remeasurement of defined benefit obligation (net of tax)	-	-	(8.23)	-	-	-	(8.23)
Amount recognised during the year	-	-	-	-	-	1.80	1.80
Share-based payments (Note 25)	-	-	-	0.77	-	-	0.77
Effective portion of gain and losses on designated portion of hedging instruments in a cash flow hedge (net of tax)	-	-	-	-	29.52	-	29.52
Share issue expenses	-	(52.51)	-	-	-	-	(52.51)
<b>Subtotal at March 31, 2017-Proforma Ind AS</b>	<b>865.74</b>	<b>(40.45)</b>	<b>2,477.83</b>	<b>27.86</b>	<b>50.17</b>	<b>(572.37)</b>	<b>2,808.76</b>
Less: Amount recoverable from Uniparts Employees Stock option	76.44	-	-	-	-	-	76.44
<b>At March 31, 2017-Proforma Ind AS</b>	<b>789.30</b>	<b>(40.45)</b>	<b>2,477.83</b>	<b>27.86</b>	<b>50.17</b>	<b>(572.37)</b>	<b>2,732.33</b>
<b>Balance as at April 1, 2015 - Proforma Ind AS</b>	<b>865.74</b>	<b>12.05</b>	<b>1,819.93</b>	<b>25.60</b>	<b>-</b>	<b>(493.25)</b>	<b>2,230.08</b>
- Profit for the year	-	-	447.12	-	-	-	447.12
Amount recognised during the year	-	-	-	-	-	(80.92)	(80.92)
Remeasurement of defined benefit obligation (net of tax)	-	-	(5.26)	-	-	-	(5.26)
Interim Dividend	-	-	(33.85)	-	-	-	(33.85)
Reversal of dividend distribution tax	-	-	4.82	-	-	-	4.82
Share-based payments (Note 25)	-	-	-	1.49	-	-	1.49
Effective portion of gain and losses on designated portion of hedging instruments in a cash flow hedge (net of tax)	-	-	-	-	20.65	-	20.65
Dividend distribution tax (DDT)	-	-	(11.90)	-	-	-	(11.90)
<b>Subtotal at March 31, 2016 - Proforma Ind AS</b>	<b>865.74</b>	<b>12.05</b>	<b>2,220.86</b>	<b>27.09</b>	<b>20.65</b>	<b>(574.17)</b>	<b>2,572.23</b>
Less: Amount recoverable from Uniparts Employees Stock option	76.44	-	-	-	-	-	76.44
<b>At March 31, 2016 - Proforma Ind AS</b>	<b>789.30</b>	<b>12.05</b>	<b>2,220.86</b>	<b>27.09</b>	<b>20.65</b>	<b>(574.17)</b>	<b>2,495.78</b>

The accompanying Restated Consolidated Statement of Significant Accounting Policies in Annexure V and Notes to Restated Consolidated Financial Information in Annexure VI are an integral part of this statement.

As per our report of even date attached

**For Rakesh Banwari & Co.**

Chartered Accountants

Firm Regn. No: 009732N

**Rakesh Aggarwal**

Proprietor

Membership No.: 088193

Place: New Delhi

Date:

For and on behalf of the Board of Directors

**Uniparts India Limited**

**Paramjit Singh Soni**

[Vice Chairman & Director]

[DIN: 00011616]

**Gurdeep Soni**

[Chairman & Managing Director]

[DIN: 00011478]

**Mukesh Kumar**

[Company Secretary]

[ACS: 17925]

**Sanjiv Kashyap**

[Chief Financial Officer]

**1) Group Overview**

The restated consolidated financial statements comprise restated financial statements of Uniparts India Limited (“the Company”) and its subsidiaries (collectively, the Group). The Company was incorporated under the provisions of erstwhile Companies Act, 1956. The Company is domiciled in India having its registered office at Gripwel House, Block-5, C6 & 7, Vasant Kunj, New Delhi 110070, India. The Group is engaged into the objects of, inter-alia, manufacturing, sale and export of Linkage parts and Components for Off-Highway Vehicles.

Information on other related party relationships of the Group is provided in Note 36.

The Group caters to both the domestic and international markets. The Company’s CIN is U74899DL1994PLC061753. The restated consolidated financial statements were authorized for issue in accordance with a resolution of the Board of Directors in its meeting held on November 23, 2018.

**2. SIGNIFICANT ACCOUNTING POLICIES:****2.1) Basis of Preparation**

The restated consolidated financial statements of the Group have been specifically prepared for inclusion in the document to be filed by the Company with the Securities and Exchange Board of India (“SEBI”), Registrar of Companies (“RoC”) and Stock Exchanges in connection with the proposed Initial Public Offering (‘IPO’) of equity shares of the Company (referred to as the “Issue”). The Restated Consolidated Financial Information comprise of the restated consolidated statement of assets and liabilities as at September 30, 2018, March 31, 2018, March 31, 2017, March 31, 2016, the restated consolidated statement of profit and loss, the restated consolidated statement of changes in equity and restated consolidated statement of cash flows for the period ended September 30, 2018 and years ended March 31, 2018, March 31, 2017 and March 31, 2016 and accompanying restated consolidated statements of significant accounting policies and notes to restated consolidated financial information (hereinafter collectively referred to as “the Restated Consolidated Financial Information”).

The restated consolidated financial information has been prepared to comply in all material respects with the requirements of Section 26 of Part I of Chapter III of the Companies Act, 2013 (“the Act”) and the Securities and Exchange Board of India (Issue of Capital and Disclosure requirements) Regulations, 2018 (“ICDR Regulations”).

For all periods up to and including the year ended March 31, 2017, the Group prepared its financial statements in accordance with accounting standards notified under the section 133 of the Companies Act 2013, read together with paragraph 7 of the Companies (Accounts) Rules, 2014 (Indian GAAP) and have been translated into figures as per the Ind AS to align with accounting policies, exemptions and disclosures as adopted by the company on its first time adoption of Ind AS on April 1, 2017 (“transition date”) and are captioned as “Proforma Ind AS Restated Consolidated Financial Information” according to Guidance Note issued by Institute of Chartered Accountants of India on Reports in Company Prospectus. The restated consolidated financial statement of the Group for the period ended September 30, 2018 and year ended March 31, 2018 (Comparative) has been prepared under Ind AS. Refer to note 39 for information on how the Group adopted Ind AS.

The Restated consolidated financial information have been prepared on the historical cost basis except for the following items:

- Derivative instruments at fair value;
- Net defined benefit (asset)/liability at fair value of plan assets less present value of defined benefit obligations.
- Certain financial assets and liabilities measured at fair value (refer accounting policy related to financial instruments)

The Group's functional currency is Indian Rupees (INR) and the restated consolidated financial statements are presented in INR and all values are presented in million (INR 000,000), except when otherwise indicated.

**2.2) Basis of Consolidation**

The restated consolidated financial statements comprise the restated financial statements of the Company and its subsidiaries as at September 30, 2018, March 31 2018, March 31, 2017 and March 31, 2016. Subsidiary companies are all entities over which the group has control. The control is achieved when the Group is exposed to, or has rights to, variable returns from its involvement with the entity and has the ability to affect those returns through its power to direct the relevant activities of the entity.

The Group re-assesses whether or not it controls an entity in case facts and circumstances indicate that there are changes to one or more of the elements of control. Consolidation of a subsidiary begins when the Group obtains control over the subsidiary and ceases when the Group loses control of the subsidiary. Assets, liabilities, income and expenses of a subsidiary acquired or disposed of during the year are included in the restated consolidated financial statements from the date the Group gains control until the date the Group ceases to control the subsidiary. Intercompany transactions, balances and unrealised gain/loss on transactions between group companies are eliminated.

Restated consolidated financial statements are prepared using uniform accounting policies for like transactions and other events in similar circumstances. If a member of the group uses accounting policies other than those adopted in the consolidated financial statements for like transactions and events in similar circumstances, appropriate adjustments are made to that group member’s financial statements in preparing the consolidated financial statements to ensure conformity with the group’s accounting policies.

**2.3) Business combinations and goodwill**

In accordance with Ind AS 101 provisions related to first time adoption, the Group has elected to apply Ind AS accounting for business combinations from 1 April 2017. As such, Indian GAAP balances relating to business combinations entered into before that date, including goodwill, have been carried forward with minimal adjustment. Business combinations are accounted for using the acquisition method. The cost of an acquisition is measured as the aggregate of the consideration transferred at fair value on acquisition date and the amount of any non-controlling interests in the acquire. For each business combination, the Group elects whether to measure the non-controlling interests in the acquire at fair value or at the proportionate share of the acquiree's identifiable net assets. Acquisition related costs are expensed as incurred.

At the acquisition date, the identifiable assets acquired and the liabilities assumed are recognised at their acquisition date fair values. For this purpose, the liabilities assumed include contingent liabilities representing present obligation and they are measured at their acquisition fair values irrespective of the fact that outflow of resources embodying economic benefits is not probable. However, the following assets and liabilities acquired in a business combination are measured at the basis indicated below:

- ▶ Deferred tax assets or liabilities, and the assets or liabilities related to employee benefit arrangements are recognised and measured in accordance with Ind AS 12 Income Tax and Ind AS 19 Employee Benefits respectively.

When the Group acquires a business, it assesses the financial assets and liabilities assumed for appropriate classification and designation in accordance with the contractual terms, economic circumstances and pertinent conditions as at the acquisition date. This includes the separation of embedded derivatives in host contracts by the acquire.

Contingent consideration classified as an asset or liability that is a financial instrument and within the scope of Ind AS 109 Financial Instruments, is measured at fair value with changes in fair value recognised in the statement of profit and loss. If the contingent consideration is not within the scope of Ind AS 109, it is measured in accordance with the appropriate Ind AS. Contingent consideration that is classified as equity is not remeasured at subsequent reporting dates and subsequent its settlement is accounted for within equity.

Goodwill is initially measured at cost, being the excess of the aggregate of the consideration transferred and the amount recognised for non-controlling interests, and any previous interest held, over the net identifiable assets acquired and liabilities assumed. If the fair value of the net assets acquired is in excess of the aggregate consideration transferred, the Group reassesses whether it has correctly identified all of the assets acquired and all of the liabilities assumed and reviews the procedures used to measure the amounts to be recognised at the acquisition date. If the reassessment still results in an excess of the fair value of net assets acquired over the aggregate consideration transferred, then the gain is recognised in Other Comprehensive Income (OCI) and accumulated in equity as capital reserve. However, if there is no clear evidence of bargain purchase, the Company recognises the gain directly in equity as capital reserve, without routing the same through OCI.

After initial recognition, goodwill is measured at cost less any accumulated impairment losses. For the purpose of impairment testing, goodwill acquired in a business combination is, from the acquisition date, allocated to each of the Group's cash-generating units that are expected to benefit from the combination, irrespective of whether other assets or liabilities of the acquire are assigned to those units.

**2.4) Current versus non-current classification**

The assets and liabilities are presented as current or non-current in the balance sheet by the company.

An asset is treated as current when it is expected that it will be realised or intended to be sold or consumed in normal operating cycle, it is held primarily for trading purposes, it is expected to be realised within twelve months after the reporting period or cash or cash equivalents unless restricted from being exchanged or used to settle a liability for at least twelve months after the reporting period.

All other assets are treated as non-current in the balance sheet.

A liability is treated as current when it is expected to be settled in normal operating cycle, if it is held primarily for the purpose of trading, it is due to be settled within twelve months after the end of the reporting period or there is no unconditional right to defer the settlement of the liability for at least twelve months after the reporting period.

The Group classifies all other liabilities as non-current in the balance sheet.

The Group identifies its operating cycle as twelve months.

Deferred tax asset and liabilities are classified as non-current assets or liabilities in the balance sheet.

**2.5) Critical Accounting Judgments & key sources of Estimation uncertainties**

The following are the critical judgments and the key estimates concerning the future that management has made in the process of applying the Group's accounting policies and these may have the most significant effect on the amounts recognized in the Restated Consolidated financial statements or have a significant risk of causing a material adjustment to the carrying amounts of assets and liabilities within the next financial year. The estimates and associated assumptions are based on historical experiences and other factors that are considered to be relevant. The estimates and underlying assumptions are reviewed on an on-going basis. Revision of accounting estimates are recognised in the period in which the estimates are revised if the revision affects only that period or in the period of the revision and future periods where revision affects both current and future periods.



**Intangible Assets**

Capitalization of cost for intangible assets and intangible assets under development is based on the management judgment that technological and economic feasibility is confirmed and assets under development will generate economic benefits in future. Based on the evaluation carried out, the Group's management has determined that there are no factors which indicate that those assets have suffered any impairment loss.

**Useful life of depreciable Assets**

Management reviews the useful life of depreciable assets at each reporting date. As at September 30, 2018, management assessed that the useful life represents the expected utility of the assets by the company. Further there is no significant change in useful life as compared to the previous year.

**Impairment of non-financial assets**

The Group assesses at each reporting date whether there is an indication that an asset may be impaired. If any indication exist, or when annual impairment testing for an asset is required, the Group estimates the asset's recoverable amount. An asset's recoverable amount is the higher of an asset's or Cash Generating Unit's (CGU) fair value less costs of disposal and its value in use. It is determined for an individual asset, unless the asset or CGU exceeds its recoverable amount, the asset is considered impaired and is written down to its recoverable amount.

In assessing the value in use, the estimated future cash flows are discounted to their present value using a pre-tax discount rate that reflects current market assessments of the time value of money and risks specific to the asset. In determining the fair value less costs to disposal, recent market transactions are taken into account. If no such transactions can be identified, an appropriate valuation model is used.

Intangible assets under development are tested for impairment annually. Impairment losses including impairment on inventories are recognised in the Restated Consolidated statement of profit and loss.

**Impairment of financial assets**

The impairment provisions for financial assets are based on assumptions about risk of default and expected loss rates. The Company uses judgment in making these assumptions and selecting the inputs to the impairment calculation, based on Group's past history, existing market conditions as well as forward looking estimates at the end of each reporting period.

**Defined benefit plans**

The cost of the defined benefit gratuity plan, other post-employment plans and the present value of the gratuity obligation is determined using actuarial valuations. An actuarial valuation involves making various assumptions that may differ from actual developments in the future. These include the determination of the discount rate, future salary increases and mortality rates. Due to the complexities involved in the valuation and its long-term nature, a defined benefit obligation is highly sensitive to changes in these assumptions. All assumptions are reviewed at each reporting date.

The mortality rate is based on publicly available mortality tables for India. Those mortality tables tend to change only at interval in response to demographic changes.

Further details about gratuity obligations are given in Note 34

**Fair value measurement of financial instruments**

When the fair values of financial assets and financial liabilities recorded in the balance sheet cannot be measured based on quoted prices in active markets, their fair value is measured using suitable valuation techniques. The inputs to these models are taken from observable markets where possible, but where this is not feasible, a degree of judgment is required in establishing fair values. Judgments include considerations of inputs such as liquidity risk, credit risk and volatility. Changes in assumptions about these factors could affect the reported fair value of financial instruments. See Note 43 for further disclosures.

**Income tax and deferred tax**

Significant management judgment is required to determine the amount of deferred tax assets that can be recognised, based upon the likely timing and the level of future taxable profits together with future tax planning strategies.

**2.6) Financial Instruments**

A financial instrument is any contract that gives rise to a financial asset of one entity and a financial liability or equity instrument of another entity.

**Initial Recognition and measurement**

On initial recognition, all the financial assets are recognized at their fair value plus or minus, in the case of a financial asset or financial liability not at fair value through profit or loss (FVTPL), transaction costs that are directly attributable to the acquisition or issue of the financial asset or financial liability. All financial liabilities are recognised initially at fair value and, in the case of loans, borrowings and payables, net of directly attributable transaction costs. The Group's financial liabilities include trade and other payables, loans and borrowings including bank overdrafts and derivative financial instruments.

**Subsequent measurement****(i) Financial assets carried at amortised cost**

A financial asset is subsequently measured at amortised cost if it is held within a business model whose objective is to hold the asset in order to collect contractual cash flows and the contractual terms of the financial asset give rise on specified dates to cash flows that are solely payments of principal and interest on the principal amount outstanding.

The trade & other receivables, after initial measurement are subsequently measured at amortised cost using the effective interest rate (EIR) method. Amortised cost is calculated by taking into account any discount or premium on acquisition and fees or costs that are an integral part of the EIR. The EIR amortisation is included in other income in the statement of profit and loss. The losses arising from impairment are recognised in the statement of profit and loss.

**(ii) Financial assets at fair value through other comprehensive income (FVTOCI)**

A financial asset is subsequently measured at fair value through other comprehensive income if it is held within a business model whose objective is achieved by both collecting contractual cash flows and selling financial assets, and the contractual terms of the financial asset give rise on specified dates to cash flows that are solely payments of principal and interest on the principal amount outstanding.

Financial assets included within the FVTOCI are measured initially as well as at each reporting date at fair value. Fair value movements are recognized in the other comprehensive income (OCI). However, the company recognizes interest income, impairment losses, reversals and foreign exchange gain or loss in the statement of profit and loss. On derecognition of the asset, cumulative gain or loss previously recognised in OCI is reclassified from the equity to statement of profit and loss. Interest earned whilst holding FVTOCI debt instrument is reported as interest income using the EIR method.

**(iii) Financial assets at fair value through profit or loss (FVTPL)**

A financial asset which is not classified in any of the above categories is subsequently measured at fair value through profit or loss.

**(iv) Financial liabilities**

a) The financial liabilities are subsequently carried at amortized cost using the effective interest method. For trade and other payables maturing within one year from the balance sheet date, the carrying amounts approximate fair value due to the short-term maturity of these instruments. This category also includes derivative financial instruments entered into by the Company that are not designated as hedging instruments in hedge relationships as defined by Ind AS 109.

b) Loans and borrowings is the category most relevant to the Group. After initial recognition, interest-bearing loans and borrowings are subsequently measured at amortised cost using the EIR method. Gains and losses are recognised in statement of profit and loss when the liabilities are derecognised as well as through the EIR amortisation process. In the calculation of amortised cost, discount or premium on acquisition and fees or costs that are an integral part of the EIR are taken into account. This category generally applies to borrowings.

**Fair value measurement of financial instruments**

The fair value of financial instruments is determined using the valuation techniques that are appropriate in the circumstances and for which sufficient data are available to measure fair value, maximising the use of relevant observable inputs and minimising the use of unobservable inputs.

Based on the three level fair value hierarchy, the methods used to determine the fair value of financial assets and liabilities include quoted market price, discounted cash flow analysis and valuation certified by the external valuer.

In case of financial instruments where the carrying amount approximates fair value due to the short maturity of those instruments, carrying amount is considered as fair value.

**Derecognition of financial instrument**

A financial asset is derecognized when the contractual rights to the cash flows from the financial asset expire or has transferred the financial asset and the transfer qualifies for derecognition under Ind AS 109.

When the Group has transferred its rights to receive cash flows from an asset or has entered into a pass through arrangement, it evaluates if and to what extent it has retained the risks and rewards of ownership. When it has neither transferred nor retained substantially all of the risks and rewards of the asset, nor transferred control of the asset, the Company continues to recognise the transferred asset to the extent of the Company's continuing involvement. In that case, the Group also recognises an associated liability. The transferred asset and the associated liability are measured on a basis that reflects the rights and obligations that the Group has retained.

A financial liability is derecognized when the obligation specified in the contract is discharged or cancelled or expired. When an existing financial liability is replaced by another from the same lender on substantially different terms, or the terms of an existing liability are substantially modified, such an exchange or modification is treated as the derecognition of the original liability and the recognition of a new liability. The difference in the respective carrying amounts is recognised in the statement of profit and loss.

**2.7) Inventories**

Inventories are valued as below:

- (i) Raw Materials, Packing Materials and Consumable Stores & Spares are valued at cost computed on FIFO method.
- (ii) Work-in-progress are valued at materials cost plus appropriate share of labour and production overheads incurred till the stage of completion of production.
- (iii) Finished Goods/Traded Goods are valued at lower of the cost or net realizable value.
- (iv) Scrap is valued at net realizable value calculated based on last month's average realization.

**2.8) Revenue Recognition**

Revenue is recognised to the extent it is probable that the economic benefits will flow to the Company and the revenue can be reliably measured, regardless of when the payment is being made. Revenue is measured at the fair value of the consideration received or receivable, taking into account contractually defined terms of payment and excluding taxes or duties collected on behalf of the government.

Revenue is presented gross of excise duties, wherever applicable. However, sales tax/ value added tax (VAT)/Goods & Service Tax (GST) is not received by the Company on its own account. Rather, it is tax collected on value added to the commodity by the Company on behalf of the Government. Accordingly, these are excluded from revenue.

The specific recognition criteria as described below must also be met before revenue is recognised.

**Sale of Goods**

Revenue is recognised when the customer obtains control of the goods. The customer obtains control of goods at the different point in time based on the delivery terms. Accordingly, Group satisfies its performance obligation at the time of dispatch of goods from the factory/stockyard/storage area/port as the case may be and accordingly revenue is recognised. Revenue from the sale of goods is measured at the fair value of the consideration received or receivable, net of returns and allowances, trade discounts and volume rebates.

The determination of transaction price, its allocation to promised goods and allocation of discount or variable compensation (if any) is done based on the contract with the customers.

The incremental costs that the Group incurs to obtain a contract with a customer that it would not have incurred if the contract had not been obtained are recognised as an asset if its recovery is expected and its amortisation period is more than one year, all other such costs are recognised as an expense in Restated Consolidated statement of profit and loss. The incremental cost recognised as an asset is amortised over the period till when such cost is expected to be recovered. Amount so recovered is recognised as revenue in Restated Consolidated statement of profit and loss.

**Export incentives**

Revenue from export incentives are accounted for on export of goods if the entitlements can be estimated with reasonable assurance and conditions precedent to claim are fulfilled.

**Interest income**

For all debt instruments measured either at amortised cost or at fair value through other comprehensive income, interest income is recorded using the effective interest rate (EIR). EIR is the rate that exactly discounts the estimated future cash receipts over the expected life of the financial instrument or a shorter period, where appropriate, to the gross carrying amount of the financial asset or to the amortised cost of a financial liability. When calculating the effective interest rate, the Company estimates the expected cash flows by considering all the contractual terms of the financial instrument (for example, prepayment, extension, call and similar options) but does not consider the expected credit losses. Interest income is included in other income in the statement of profit and loss.

**Dividends**

Dividend income is recognised when the Group's right to receive the payment is established, which is generally when shareholders approve the dividend.

**2.9) Government grants**

Government grants are recognised where there is reasonable assurance that the grant will be received and all attached conditions will be complied with. When the grant or subsidy relates to revenue, it is recognized as income on a systematic basis in the restated consolidated statement of profit and loss over the periods necessary to match them with the related costs, which they are intended to compensate.

Where the grant relates to an asset, it is recognized as deferred income and is allocated to restated consolidated statement of profit and loss over the periods and in the proportions in which depreciation on those assets is charged.

**2.10) Property, Plant & Equipment****Tangible Assets**

Since there is no change in the functional currency, the Group has elected to continue with the carrying value for all of its property, plant and equipment as recognised in its Indian GAAP financial statements as deemed cost at the transition date, viz., April 1, 2017.

Depreciation on tangible assets is provided on the straight-line method at the rates and manner prescribed under Schedule II of the Companies Act, 2013 except in the case of Plant and Machinery where the depreciation has been provided on the basis of the useful lives of the assets estimated by the management based on internal assessment and independent technical evaluation carried out by external Chartered Engineer at the time of adoption of Companies Act, 2013. Depreciation for the assets purchased / sold during the year is proportionately charged.

The estimated useful lives are as mentioned below:

Type of Asset	Method	Useful Lives
Leasehold land	Straight Line	Over the period of lease or estimated useful life, whichever is lower.
Factory Building	Straight Line	30 Years
Furniture & Fittings	Straight Line	10 Years
Plant and Machinery	Straight Line	15 - 20 Years
Office Equipment	Straight Line	5 Years
Electrical Installment	Straight Line	10 Years
Computers	Straight Line	3 Years
Vehicles	Straight Line	8 Years

An item of property, plant and equipment and any significant part initially recognised is derecognised upon disposal or when no future economic benefits are expected from its use or disposal. Any gain or loss arising on derecognition of the asset (calculated as the difference between the net disposal proceeds and the carrying amount of the asset) is included in the income statement when the asset is derecognised.

The residual values, useful lives and methods of depreciation of property, plant and equipment are reviewed at each financial year end and adjusted prospectively, if appropriate.

Property, plant and equipment are stated at cost of acquisition or construction net of accumulated depreciation and impairment loss (if any). Internally manufactured property, plant and equipment are capitalized at cost, including non-deductible excise duty, wherever applicable, GST wherever applicable. All significant costs relating to the acquisition and installation of property, plant and equipment are capitalised. Such cost includes the cost of replacing part of the property, plant and equipment and borrowing costs for long-term construction projects if the recognition criteria are met. When significant parts of plant and equipment are required to be replaced at intervals, the Company depreciates them separately based on their specific useful lives. Likewise, when a major inspection is performed, its cost is recognised in the carrying amount of the plant and equipment as a replacement if the recognition criteria are satisfied. All other repair and maintenance costs are recognised in statement of profit and loss as incurred. The present value of the expected cost for the decommissioning of an asset after its use is included in the cost of the respective asset if the recognition criteria for a provision are met. Refer to note regarding significant accounting judgments, estimates and assumptions and provisions for further information.

Subsequent costs are included in the asset's carrying amount or recognised as a separate asset, as appropriate, only when it is probable that future economic benefits associated with the item will flow to the Company and the cost of the item can be measured reliably. The carrying amount of the replaced part is derecognised.

### **2.11) Intangible Assets**

#### **Recognition and initial measurement**

Purchased Intangible assets are stated at cost less accumulated amortisation and impairment, if any.

#### **Goodwill**

Goodwill is initially measured at cost, being the excess of the aggregate of the consideration transferred and the amount recognised for non-controlling interests, and any previous interest held, over the net identifiable assets acquired and liabilities assumed. If the fair value of the net assets acquired is in excess of the aggregate consideration transferred, the Group re-assesses whether it has correctly identified all of the assets acquired and all of the liabilities assumed and reviews the procedures used to measure the amounts to be recognised at the acquisition date. If the reassessment still results in an excess of the fair value of net assets acquired over the aggregate consideration transferred, then the gain is recognised in OCI and accumulated in equity as capital reserve. However, if there is no clear evidence of bargain purchase, the entity recognises the gain directly in equity as capital reserve, without routing the same through OCI.

After initial recognition, goodwill is measured at cost less any accumulated impairment losses. For the purpose of impairment testing, goodwill acquired in a business combination is, from the acquisition date, allocated to each of the Group's cash-generating units that are expected to benefit from the combination, irrespective of whether other assets or liabilities of the acquire are assigned to those units.

### **2.12) Foreign Currency Transactions**

#### **Functional and presentation currency**

The financial statements are presented in Indian Rupee (INR) and are rounded to two decimal places of Million, which is also the functional and presentation currency of the Group.

#### **Transactions and balances**

Foreign currency transactions are recorded in the functional currency, by applying to the exchange rate between the functional currency and the foreign currency at the date of the transaction.

Foreign currency monetary items are converted to functional currency using the closing rate. Non-monetary items denominated in a foreign currency which are carried at historical cost are reported using the exchange rate at the date of the transactions.

Exchange differences arising on monetary items on settlement, or restatement as at reporting date, at rates different from those at which they were initially recorded, are recognised in the statement of profit and loss in the year in which they arise.

### **2.13) Employee Benefits**

#### **(i) Short term employee benefits**

All employee benefits that are expected to be settled wholly within twelve months after the end of the period in which the employees render the related service, are classified as short term employee benefits, which include salaries, wages, short term compensated absences and performance incentives and are measured at the amounts expected to be paid when the liabilities are settled. The liabilities are presented as current employee benefit obligations in the balance sheet. These are recognised as expenses in the period in which the employee renders the related service.

**(ii) Post-employment benefits**

Contributions towards Superannuation Fund, Pension Fund and government administered Provident Fund are treated as defined contribution schemes. In respect of contributions made to government administered Provident Fund, the Group has no further obligations beyond its monthly contributions. Such contributions are recognised as expense in the period in which the employee renders related service.

The cost of defined benefit such as is determined using the projected unit credit method, with actuarial valuation being carried out at each balance sheet date. Actuarial gains and losses in respect of the same are charged to the Other Comprehensive Income (OCI).

**(iii) Other long-term benefits**

All employee benefits other than post-employment benefits and termination benefits, which do not fall due wholly within twelve months after the end of the period in which the employees render the related service, including long term compensated absences, service awards, and ex-gratia are determined based on actuarial valuation carried out at each balance sheet date. Estimated liability on account of long term employee benefits is discounted to the present value using the yield on government bonds as the discounting rate for the term of obligations as on the date of the balance sheet. Actuarial gains and losses in respect of the same are charged to the statement of profit and loss.

**(iv) Termination benefits**

Termination benefits are payable when employment is terminated by the Group before the normal retirement date, or when an employee accepts voluntary retirement in exchange of these benefits. The Company recognises termination benefits at the earlier of the following dates:

- (a) when the Company can no longer withdraw the offer of those benefits; and
- (b) when the entity recognises costs for a restructuring that is within the scope of Ind AS 37 and involves the payment of termination benefits. The termination benefits are measured based on the number of employees expected to accept the offer in case of voluntary retirement scheme.

**2.14) Leases****Finance leases**

Management applies judgment in considering the substance of a lease agreement and whether it transfers substantially all the risks and rewards incidental to ownership of the leased asset. Key factors considered include i) the length of the lease term in relation to the economic life of the asset, ii) the present value of the minimum lease payments in relation to the asset's fair value, and iii) whether the Company obtains ownership of the asset at the end of the lease term.

Where the Company is a lessee in this type of arrangement, the related asset is recognised at the inception of the lease at the fair value of the leased asset or, if lower, the present value of the lease payments plus incidental payments, if any. A corresponding amount is recognized as a finance lease liability. Assets held under finance leases (including land) are depreciated over the length of the lease. The corresponding finance lease liability is reduced by lease payments net of finance charges. The interest element of lease payments represents a constant proportion of the outstanding capital balance and is charged to statement of profit and loss, as finance costs over the period of the lease.

The interest element of lease payments is charged to profit or loss as finance costs over the period of the lease.

**Operating lease**

All leases other than finance leases are treated as operating leases.

Where the Group is a lessee, lease rental are charged to restated consolidated statement of profit and loss on straight line basis except where scheduled increase in rent compensate the lessor for expected inflationary costs. Associated costs, such as maintenance and insurance, are expensed as incurred.

Where the Group is a lessor, lease rental are charged to restated consolidated statement of profit and loss on straight line basis except where scheduled increase in rent compensate the lessor for expected inflationary costs. Associated costs, such as maintenance and insurance, are expensed as incurred.

**2.15) Taxation****a) Current Tax**

Current income tax assets and liabilities are measured at the amount expected to be recovered from or paid to the taxation authorities. The tax rates and tax laws used to compute the amount are those that are enacted or substantively enacted, at the reporting date in the countries where the Group operates and generates taxable income.

Current income tax relating to items recognised outside profit or loss is recognised outside profit or loss (either in other comprehensive income or in equity). Current tax items are recognised in correlation to the underlying transaction either in OCI or directly in equity. Management periodically evaluates positions taken in the tax returns with respect to situations in which applicable tax regulations are subject to interpretation and establishes provisions where appropriate.

**b) Deferred Tax**

Deferred income tax is provided in full, using the liability method, on temporary differences arising between the tax bases of assets and liabilities and their carrying amounts in the financial statements. Deferred tax assets are recognised and carried forward only if it is probable that sufficient future taxable income will be available against which such deferred tax assets can be realised. Deferred tax assets and liabilities are measured at the tax rates that have been enacted or substantively enacted as on the balance sheet date. Deferred tax assets and deferred tax liabilities are offset when there is a legally enforceable right to set off assets against liabilities representing current tax. Current and deferred tax is recognised in profit and loss, except to the extent that it relates to items recognised in other comprehensive income. In this case, the tax is also recognised in other comprehensive income.

The carrying amount of deferred tax assets is reviewed at the end of each reporting period and reduced to the extent that it is no longer probable that sufficient taxable profits will be available to allow all or part of the asset to be recovered.

**2.16) Employee Stock options**

The Group has accounted for the share based payment for employees in respect of Company's ESOP - based on the IND AS 102 " Share-based payments" and Guidance Note on "Accounting for Employees Share Based Payment" issued by ICAI ("Guidance Note"). The Company follows the Fair Market Value Method (calculated on the basis of Black-Scholes method) to account for compensation expenses arising from issuance of stock options to the employees and has recognized the services received in an equity-settled employee share-based payment plan as an expense when it receives the services, with a corresponding credit to Stock Options Outstanding Account. Further, employees compensation cost recognized earlier on grant of options is reversed in the year when the Options are surrendered by the employee.

**2.17) Borrowings & Borrowing Costs**

Borrowings are recognised initially at fair value, net of transaction costs incurred. Borrowings are subsequently stated at amortised cost. Any difference between the proceeds (net of transaction costs) and the redemption value is recognised in the income statement over the period of the borrowings using the effective interest rate method. Borrowings are classified as current liabilities unless the Company has an unconditional right to defer settlement of the liability for at least 12 months after the reporting date.

Borrowing costs directly attributable to the acquisition, construction or production of qualifying assets, which are assets that necessarily take a substantial period of time to get ready for their intended use or sale, are added to the cost of those assets, until such time as the assets are substantially ready for their intended use or sale.

Interest income earned on the temporary investment of specific borrowings, pending their expenditure on qualifying assets, is deducted from the borrowing costs eligible for capitalisation.

All other borrowing costs are recognised in restated consolidated statement of profit and loss in the period in which they are incurred.

**2.18) Impairment of Assets****Non-financial assets**

Intangible assets and property, plant and equipment are evaluated for recoverability whenever events or changes in circumstances indicate that their carrying amounts may not be recoverable. For the purpose of impairment testing, the recoverable amount (i.e. the higher of the fair value less cost to sell and the value-in-use) is determined on an individual asset basis unless the asset does not generate cash flows that are largely independent of those from other assets. In such cases, the recoverable amount is determined for the CGU to which the asset belongs.

If such assets are considered to be impaired, the impairment to be recognized in the restated consolidated statement of profit and loss is measured by the amount by which the carrying value of the assets exceeds the estimated recoverable amount of the asset. An impairment loss is reversed in the statement of profit and loss if there has been a change in the estimates used to determine the recoverable amount. The carrying amount of the asset is increased to its revised recoverable amount, provided that this amount does not exceed the carrying amount that would have been determined (net of any accumulated amortization or depreciation) had no impairment loss been recognized for the asset in prior years.

**Financial assets**

The company recognizes loss allowances using the expected credit loss (ECL) model for the financial assets which are not fair valued through profit or loss.

Loss allowance for trade receivables with no significant financing component is measured at an amount equal to lifetime ECL.

**2.19) Cash and Cash Equivalents**

Cash and cash equivalents includes cash and cheques in hand, current accounts and fixed deposit accounts with banks with original maturities of three months or less that are readily convertible to known amounts of cash and which are subject to an insignificant risk of changes in value.

**2.20) Cash Flow Statement**

Cash flows are reported using the indirect method, whereby a profit before tax is adjusted for the effects of transactions of non-cash nature and any deferrals or accruals of past or future cash receipts or payments. The cash flows from operating, financing and investing activities of the Company are segregated.

**2.21) Provisions and Contingencies**

Provisions are recognised when the Group has a present legal or constructive obligation as a result of past events, for which it is probable that an outflow of resources embodying economic benefits will be required to settle the obligation and a reliable estimate of the amount can be made.

Provisions are measured at the present value of management's best estimate of the expenditure required to settle the present obligation at the end of the reporting period. The discount rate to determine the present value is a pre-tax rate that reflects current market assessments of the time value of money and the risks specific to the liability. The increase in the provision due to the passage of time is recognised as interest expense.

Contingent liabilities are disclosed when there is a possible obligation arising from past events, the existence of which will be confirmed only by the occurrence or non occurrence of one or more uncertain future events not wholly within the control of the group or a present obligation that arises from past events where it is either not probable that an outflow of resources will be required to settle or a reliable estimate of the amount cannot be made.

**2.22) Derivative financial instruments and hedge accounting****Cash Flow Hedge:**

The Group holds derivative financial instruments such as foreign exchange forward and option contracts to mitigate the risk of changes in exchange rates on foreign currency exposures.

The effective portion of changes in the fair value of the hedging instruments is recognized in other comprehensive income and accumulated in the cash flow hedging reserve. Such amounts are reclassified in to the restated consolidated statement of profit or loss when the related hedge items affect profit or loss. Any ineffective portion of changes in the fair value of the derivative or if the hedging instrument no longer meets the criteria for hedge accounting, is recognized immediately in the statement of profit and loss.

Any derivative that is either not designated a hedge, or is so designated but is ineffective as per Ind AS 109, is categorized as a financial instruments at fair value through profit or loss.

**2.23) Dividend to equity holders of the Company**

The Group recognises a liability to make cash or non-cash distributions to equity holders of the Group when the distribution is authorised and the distribution is no longer at the discretion of the Group. As per the Corporate laws in India, a distribution is authorised when it is approved by the shareholders. A corresponding amount is recognised directly in other equity.

**2.24) Segment reporting**

Operating segments are reported in a manner consistent with the internal reporting provided to the chief operating decision-maker.

**2.25) Earnings Per Share**

Earning per share is calculated by dividing the profit attributable to owners of the company by the weighted average number of equity shares outstanding during the financial year.

For the purpose of calculating diluted earnings per share, the net profit or loss for the year attributable to equity shareholders and the weighted average number of shares outstanding during the year are adjusted for the effects of all dilutive potential equity shares.



UNIPARTS INDIA LIMITED

Annexure VI : Notes to Restated Consolidated Financial Information

(All amounts in millions of INR, unless stated otherwise)

3. Property, Plant and Equipment

Particulars	Freehold Land	Leasehold Land Note (a)	Buildings Note (b)	Leasehold Improvements	Plant & Machinery	Furniture & Fittings	Vehicles	Computers	Total
<b>Cost</b>									
at April 1, 2015 - Proforma Ind AS	34.33	237.63	580.90	15.17	2,022.11	46.53	95.47	92.16	3,124.30
Exchange fluctuation	-	(1.30)	(3.77)	-	(46.03)	(0.11)	(0.91)	(0.68)	(52.80)
Additions	-	73.88	38.36	-	259.43	2.69	8.82	10.85	394.03
Disposals	-	-	4.24	-	40.96	0.17	10.49	0.29	56.15
at March 31, 2016 - Proforma Ind AS	34.33	312.81	618.79	15.17	2,286.61	49.16	94.71	103.40	3,514.98
Exchange fluctuation	-	0.46	1.26	-	16.76	0.04	0.33	0.28	19.13
Additions	-	-	2.37	-	138.93	1.08	4.53	8.53	155.44
Disposals	-	-	-	-	13.71	0.02	14.71	3.72	32.16
at March 31, 2017 - Proforma Ind AS	34.33	312.35	619.90	15.17	2,395.07	50.18	84.20	107.93	3,619.13
Other Adjustments	-	-	-	-	1.78	(1.58)	-	-	0.20
Exchange fluctuation	-	(0.08)	(0.23)	-	(4.04)	(0.01)	(0.06)	(0.14)	(4.56)
Additions	-	-	12.96	-	206.82	0.71	0.07	9.76	230.31
Disposals	-	-	-	-	2.55	-	8.09	-	10.65
at March 31, 2018	34.33	312.43	633.09	15.17	2,605.16	49.32	76.23	117.84	3,843.57
Other Adjustments	-	-	-	-	-	-	-	-	-
Exchange fluctuation	-	(2.42)	(8.01)	-	(91.46)	(0.25)	(1.76)	(1.24)	(105.15)
Additions	-	-	146.53	-	300.20	1.00	0.71	10.45	458.88
Disposals	-	-	-	-	25.74	2.71	0.21	4.42	33.08
at September 30, 2018	34.33	314.85	787.63	15.17	2,971.07	47.86	78.49	125.10	4,374.51
<b>Accumulated Depreciation and impairment</b>									
at April 1, 2015- Proforma Ind AS	-	-	122.81	4.76	1,150.58	28.07	55.98	62.36	1,424.56
Exchange fluctuation	-	-	(0.83)	-	(39.47)	(0.09)	(0.83)	(0.57)	(41.79)
Charge for the year	-	5.49	17.03	1.72	122.70	6.68	7.02	11.26	171.90
On Disposals	-	-	-	-	42.06	0.16	8.29	0.25	50.76
at March 31, 2016- Proforma Ind AS	-	5.49	140.67	6.48	1,270.69	34.68	55.54	73.94	1,587.49
Exchange fluctuation	-	-	0.30	-	13.96	0.03	0.24	0.25	14.79
Charge for the year	-	6.21	19.73	1.72	136.36	2.96	6.82	11.20	185.00
On Disposals	-	-	-	-	11.92	0.01	7.80	3.54	23.27
at March 31, 2017 - Proforma Ind AS	-	11.70	160.10	8.20	1,381.17	37.60	54.32	81.35	1,734.43
Exchange fluctuation	-	-	(0.06)	-	(3.28)	(0.01)	(0.05)	(0.14)	(3.54)
Other Adjustments	-	-	-	-	(2.58)	2.38	-	-	(0.20)
Charge for the year	-	6.21	23.22	1.72	147.92	2.68	4.72	10.11	196.59
On Disposals	-	-	-	-	1.25	-	3.67	-	4.91
at March 31, 2018	-	17.91	183.38	9.92	1,533.70	37.91	55.42	91.60	1,929.85
Exchange fluctuation	-	-	(2.48)	-	(77.35)	(0.19)	(1.41)	(1.13)	(82.57)
Other Adjustments	-	-	-	-	-	-	-	-	-
Charge for the year	-	3.11	11.31	0.86	84.52	1.37	1.95	4.94	108.06
On Disposals	-	-	-	-	21.54	2.57	0.12	4.19	28.43
at September 30, 2018	-	21.02	197.17	10.78	1,674.03	36.90	58.66	93.48	2,092.05

UNIPARTS INDIA LIMITED

Annexure VI : Notes to Restated Consolidated Financial Information

(All amounts in millions of INR, unless stated otherwise)

<b>Net Block</b>									
at April 1, 2015 - Proforma Ind AS	34.33	237.63	458.10	10.41	871.53	18.45	39.49	29.80	1,699.75
at March 31, 2016 - Proforma Ind AS	34.33	307.32	478.12	8.69	1,015.92	14.47	39.17	29.45	1,927.48
at March 31, 2017 - Proforma Ind AS	34.33	300.66	459.80	6.97	1,013.90	12.58	29.88	26.58	1,884.69
at March 31, 2018	34.33	294.53	449.70	5.26	1,071.45	11.40	20.81	26.23	1,913.72
at September 30, 2018	34.33	293.84	590.45	4.39	1,297.04	10.95	19.84	31.63	2,282.48

Notes:-

- Company has leasehold lands in Noida, Ludhiana and Vizag.
- Refer note 14 for information on property, plant and equipment pledged as security.
- The company has elected to continue with the carrying value of plant, property & equipments as recognised in financial statements as per previous Indian GAAP and assumed it to be deemed cost. Accumulated depreciation is for disclosure purpose only.

**3A Capital Work in Progress**

Particulars	CWIP-Building	CWIP-Plant & Machinery	CWIP-Computers	CWIP-Office Equipment	CWIP-Furniture & Fixtures	CWIP-Other Expenses	Total
at April 1, 2015 - Proforma Ind AS	-	12.47	0.73	0.07	-	-	13.27
Movement during the year	0.34	2.39	2.97	0.07	0.02	1.11	6.91
at March 31, 2016 - Proforma Ind AS	0.34	14.86	3.70	0.14	0.02	1.11	20.18
Movement during the year	50.00	14.27	1.89	(0.07)	(0.02)	13.85	79.92
at March 31, 2017-Proforma Ind AS	50.34	29.13	5.59	0.07	-	14.96	100.10
Movement during the year	65.23	77.79	0.12	6.53	12.95	21.23	183.85
at March 31, 2018	115.57	106.92	5.71	6.60	12.95	36.19	283.95
Movement during the year	(91.33)	(13.72)	(3.96)	(2.76)	(11.27)	(36.19)	(159.24)
at September 30, 2018	24.24	93.20	1.75	3.84	1.68	0.00	124.71

**UNIPARTS INDIA LIMITED**
**Annexure VI : Notes to Restated Consolidated Financial Information**

(All amounts in millions of INR, unless stated otherwise)

**4. Intangible assets**

Particulars	As at September 30, 2018	As at March 31, 2018	As at March 31, 2017 Proforma Ind AS	As at March 31, 2016 Proforma Ind AS
<b>Softwares</b>				
Cost	116.93	108.38	105.06	102.09
- Exchange fluctuation	(0.06)	(0.00)	(0.01)	0.03
- Additions	2.89	8.55	3.33	2.94
<b>Total Gross Block</b>	<b>119.76</b>	<b>116.93</b>	<b>108.38</b>	<b>105.06</b>
Accumulated Depreciation/amortisation				
- Opening Balance	99.16	87.22	74.57	61.55
- Exchange fluctuation	(0.06)	(0.00)	(0.01)	0.03
- Amortisation	3.00	11.94	12.66	12.99
<b>Total Accumulated Depreciation/amortisation</b>	<b>102.10</b>	<b>99.16</b>	<b>87.22</b>	<b>74.57</b>
<b>Net Block</b>	<b>17.66</b>	<b>17.77</b>	<b>21.16</b>	<b>30.49</b>
<b>Intangible assets under development</b>	<b>24.93</b>	<b>21.60</b>	<b>18.01</b>	<b>4.48</b>

**5. Loans**

Particulars	As at September 30, 2018	As at March 31, 2018	As at March 31, 2017 Proforma Ind AS	As at March 31, 2016 Proforma Ind AS
<b>Non-current (Unsecured, Considered Good)</b>				
Loans to Employees	6.08	2.27	1.87	2.48
<b>TOTAL</b>	<b>6.08</b>	<b>2.27</b>	<b>1.87</b>	<b>2.48</b>

**6. Other financial assets**

Particulars	As at September 30, 2018	As at March 31, 2018	As at March 31, 2017 Proforma Ind AS	As at March 31, 2016 Proforma Ind AS
<b>Non-current</b>				
Security Deposits	49.97	48.37	38.30	38.33
Fixed Deposits (more than 12 months maturity)	1.14	0.09	0.05	0.05
<b>Total</b>	<b>51.11</b>	<b>48.46</b>	<b>38.36</b>	<b>38.38</b>
<b>Current</b>				
Commission Receivable	-	-	0.17	0.17
Interest Accrued but not due	0.61	0.63	0.34	0.45
<b>Total</b>	<b>0.61</b>	<b>0.63</b>	<b>0.52</b>	<b>0.62</b>
<b>TOTAL</b>	<b>51.72</b>	<b>49.09</b>	<b>38.87</b>	<b>39.00</b>

**UNIPARTS INDIA LIMITED**  
**Annexure VI : Notes to Restated Consolidated Financial Information**  
(All amounts in millions of INR, unless stated otherwise)

**7. Other assets**

Particulars	As at September 30, 2018	As at March 31, 2018	As at March 31, 2017 Proforma Ind AS	As at March 31, 2016 Proforma Ind AS
<b>Non-current</b>				
Capital Advances	44.50	54.73	27.36	11.49
<b>Total</b>	<b>44.50</b>	<b>54.73</b>	<b>27.36</b>	<b>11.49</b>
<b>Current</b>				
Advances to Suppliers	31.28	32.81	23.23	29.10
Balance with Sales Tax, Central Excise Department etc.	238.50	250.06	120.13	91.26
Government Grant - Export Incentives Receivable	86.48	95.81	94.61	111.74
Prepaid Expenses	28.24	27.09	27.52	22.73
Advance Payments, other recoverable in cash or in kind-or for value to be received	0.60	0.28	0.37	28.70
Advance Rent	4.94	5.03	2.45	3.86
Fund Raising Expenses	12.47	9.73	2.66	-
Share Issue Expenses	-	-	-	52.09
Insurance Claim Receivable	-	-	34.82	29.80
<b>Total</b>	<b>402.51</b>	<b>420.81</b>	<b>305.79</b>	<b>369.28</b>
<b>TOTAL</b>	<b>447.01</b>	<b>475.54</b>	<b>333.15</b>	<b>380.77</b>

**8. Inventories**

Particulars	As at September 30, 2018	As at March 31, 2018	As at March 31, 2017 Proforma Ind AS	As at March 31, 2016 Proforma Ind AS
Raw Materials (Includes Materials in Transit)	624.82	524.00	345.67	332.12
Work-in-Progress	1,112.35	854.88	665.32	510.51
Finished Goods (Includes Goods at Port)	1,742.08	1,397.96	1,025.30	1,220.11
Traded Goods	34.17	20.29	15.00	14.85
Stores and Spares (Includes Materials in Transit)	296.12	263.59	242.68	228.33
Scrap	4.41	7.12	2.27	4.48
<b>Sub Total</b>	<b>3,813.95</b>	<b>3,067.84</b>	<b>2,296.24</b>	<b>2,310.40</b>
Less: Provision for Obsolescence	29.00	26.04	22.70	23.19
<b>TOTAL</b>	<b>3,784.95</b>	<b>3,041.80</b>	<b>2,273.54</b>	<b>2,287.21</b>

**9. Trade receivables**

Particulars	As at September 30, 2018	As at March 31, 2018	As at March 31, 2017 Proforma Ind AS	As at March 31, 2016 Proforma Ind AS
<b>Unsecured</b>				
Considered Good	1,452.83	1,151.84	997.84	973.99
Credit Impaired	0.95	0.95	0.95	-
<b>Secured</b>				
Considered good	6.28	10.03	13.65	12.35
<b>Impairment allowance (allowance for bad and doubtful debts)</b>				
Unsecured				
Doubtful	6.39	5.83	4.19	3.31
<b>TOTAL</b>	<b>1,453.67</b>	<b>1,156.99</b>	<b>1,008.25</b>	<b>983.03</b>

Generally payment against sale of goods become due as per payment terms, and fixed transaction price as per contracts with customers.

The carrying amount of trade receivables includes receivables which are discounted with banks. Since the Company has retained the late payment and credit risk of these receivables, such receivables are not derognised and a correspondingly amount is recognised as borrowings (Refer note no. 14). Amount so recognised is INR 33.58 million for the period ended September 30, 2018, INR 37.87 million for March 31, 2018, INR 29.77 million for March 31, 2017 and INR 21.33 million for March 31, 2016.

**UNIPARTS INDIA LIMITED**  
**Annexure VI : Notes to Restated Consolidated Financial Information**  
(All amounts in millions of INR, unless stated otherwise)

**10. Cash and bank balances**

Particulars	As at September 30, 2018	As at March 31, 2018	As at March 31, 2017 Proforma Ind AS	As at March 31, 2016 Proforma Ind AS
<b>Cash and Cash Equivalents</b>				
Cash in hand	3.16	3.19	2.22	2.13
<b>Balances with Banks</b>				
Balances with Banks-in Cash Credit and Current Accounts	96.42	87.25	52.37	47.09
Balances with Banks-in EEFC Accounts	3.08	0.00	0.00	0.43
<b>Total</b>	<b>102.66</b>	<b>90.44</b>	<b>54.59</b>	<b>49.65</b>
<b>Other Bank Balances</b>				
Balance with bank				
This includes :				
Fixed Deposits (more than 3 months and less than 12 months maturity)	-	1.05	1.77	1.02
<b>Total</b>	<b>-</b>	<b>1.05</b>	<b>1.77</b>	<b>1.02</b>
<b>TOTAL</b>	<b>102.66</b>	<b>91.49</b>	<b>56.36</b>	<b>50.67</b>

**11. Derivative Instruments**

Particulars	As at September 30, 2018	As at March 31, 2018	As at March 31, 2017 Proforma Ind AS	As at March 31, 2016 Proforma Ind AS
<b>Current</b>				
Cash flow hedge				
Foreign exchange forward contracts	(65.72)	1.92	44.90	31.34
<b>TOTAL</b>	<b>(65.72)</b>	<b>1.92</b>	<b>44.90</b>	<b>31.34</b>

**UNIPARTS INDIA LIMITED****Annexure VI : Notes to Restated Consolidated Financial Information**

(All amounts in millions of INR, unless stated otherwise)

**Break up of financial asset carried at amortised cost**

<b>Particulars</b>	<b>As at September 30, 2018</b>	<b>As at March 31, 2018</b>	<b>As at March 31, 2017 Proforma Ind AS</b>	<b>As at March 31, 2016 Proforma Ind AS</b>
Loans (Refer Note 5)	6.08	2.27	1.87	2.48
Other financial assets (Refer note 6)	51.72	49.09	38.87	39.00
Trade receivables (Refer Note 9)	1,453.67	1,156.99	1,008.25	983.03
Cash and Cash equivalent (Refer Note 10)	102.66	90.44	54.59	49.65
Other Bank Balances (Refer Note 10)	-	1.05	1.77	1.02
<b>TOTAL</b>	<b>1,614.14</b>	<b>1,299.85</b>	<b>1,105.35</b>	<b>1,075.18</b>

**Break up of financial asset carried at fair value through OCI**

<b>Particulars</b>	<b>As at September 30, 2018</b>	<b>As at March 31, 2018</b>	<b>As at March 31, 2017 Proforma Ind AS</b>	<b>As at March 31, 2016 Proforma Ind AS</b>
Derivative instruments (Refer note 11)	(65.72)	1.92	44.90	31.34
<b>TOTAL</b>	<b>(65.72)</b>	<b>1.92</b>	<b>44.90</b>	<b>31.34</b>

UNIPARTS INDIA LIMITED  
Annexure VI : Notes to Restated Consolidated Financial Information  
(All amounts in millions of INR, unless stated otherwise)

12. Share capital

Particulars	As at September 30,	As at March 31,	As at March 31,	As at March 31,
	2018	2018	2017	2016
			Proforma Ind AS	Proforma Ind AS
<b>Authorised:</b>				
6,00,00,000 (March 31, 2018 : 6,00,00,000) equity shares of INR 10 each	600.00	600.00	600.00	600.00
<b>Issued</b>				
4,51,33,758 (March 31, 2018 : 4,51,33,758) equity shares of INR 10 each	451.34	451.34	451.34	451.34
<b>Issued, Subscribed and Paid-up:</b>				
4,51,33,758 (March 31, 2018 : 4,51,33,758) equity shares of INR 10 each fully Paid-up	451.34	451.34	451.34	451.34
Less: Amount recoverable from Uniparts Employees Stock Option Plan (ESOP) Trust	5.14	5.14	5.14	5.14
<b>TOTAL</b>	<b>446.20</b>	<b>446.20</b>	<b>446.20</b>	<b>446.20</b>

a. The reconciliation of the number of shares outstanding is set out as below:

Particulars	As at September 30, 2018		As at March 31, 2018		As at March 31, 2017		As at March 31, 2016	
					Proforma Ind AS		Proforma Ind AS	
	No. of Shares	Amount	No. of Shares	Amount	No. of Shares	Amount	No. of Shares	Amount
Equity Shares at the beginning of the year	45,133,758	451.34	45,133,758	451.34	45,133,758	451.34	45,133,758	451.34
Add: Issued during the year-Bonus Issue	-	-	-	-	-	-	-	-
<b>Equity Shares at the end of the year</b>	<b>45,133,758</b>	<b>451.34</b>	<b>45,133,758</b>	<b>451.34</b>	<b>45,133,758</b>	<b>451.34</b>	<b>45,133,758</b>	<b>451.34</b>

b. Terms/ rights attached to equity shares

The Company has only one class of equity shares having par value of INR 10 per share. Each holder of equity shares is entitled to one vote per share. The shareholders of equity shares of the Company are entitled to receive dividends as and when declared by the Company and enjoy proportionate voting rights in case any resolution is put to vote. In the event of liquidation of the Company, the holders of equity shares will be entitled to receive remaining assets of the Company, after distribution of all preferential amount, if any. The distribution will be in proportion to the number of equity shares held by the shareholders.

c. Aggregate number of bonus shares issued, shares issued for consideration other than cash during the period of five years immediately preceding the reporting date.

The Company has during the financial year 2013-14, issued 22,566,879 equity shares as bonus shares in the ratio of 1:1, i.e. one equity share for every one existing share held in the Company which have been allotted on Apr 04, 2014.

d. Details of shareholders holding more than 5% shares in the company

Name of the Shareholder	As at September 30, 2018		As at March 31, 2018		As at March 31, 2017		As at March 31, 2016	
					Proforma Ind AS		Proforma Ind AS	
	Number	% holding in the class	Number	% holding in the class	Number	% holding in the class	Number	% holding in the class
Gurdeep Soni	14,955,570	33.14	14,955,570	33.14	14,955,570	33.14	14,955,570	33.14
Paramjit Singh Soni	6,595,090	14.61	6,595,090	14.61	6,595,090	14.61	6,595,090	14.61
Ashoka Investment Holdings Ltd.	7,180,642	15.91	7,180,642	15.91	7,180,642	15.91	7,180,642	15.91
Karan Soni	5,200,000	11.52	5,200,000	11.52	5,200,000	11.52	5,200,000	11.52
Meher Soni	5,200,000	11.52	5,200,000	11.52	5,200,000	11.52	5,200,000	11.52

**UNIPARTS INDIA LIMITED**  
**Annexure VI : Notes to Restated Consolidated Financial Information**  
(All amounts in millions of INR, unless stated otherwise)

**13. Other equity**

Particulars	As at September 30, 2018	As at March 31, 2018	As at March 31, 2017 Proforma Ind AS	As at March 31, 2016 Proforma Ind AS
<b>Securities Premium**</b>				
Balance as per last financial statements	865.74	865.74	865.74	865.74
Add: Amount recognised during the period / year	-	-	-	-
	865.74	865.74	865.74	865.74
Less: Amount recoverable from Uniparts Employees Stock Option Plan (ESOP) Trust	76.44	76.44	76.44	76.44
<b>Total</b>	<b>789.30</b>	<b>789.30</b>	<b>789.30</b>	<b>789.30</b>
<b>Employees Stock Options Outstanding***</b>				
Balance as per last financial statements	28.15	27.86	27.09	25.60
Add: Compensation for the period / year (refer Note 25)	0.02	0.29	0.77	1.49
<b>Balance as at end of the period / year</b>	<b>28.17</b>	<b>28.15</b>	<b>27.86</b>	<b>27.09</b>
<b>Foreign currency translation reserve</b>				
Balance as per last financial statements	(636.51)	(572.37)	(574.17)	(493.25)
Add: Transfer during the period / year	(93.14)	(64.14)	1.80	(80.92)
<b>Balance as at the end of the period / year</b>	<b>(729.65)</b>	<b>(636.51)</b>	<b>(572.37)</b>	<b>(574.17)</b>
<b>General Reserve****</b>				
Balance as per last financial statements	12.05	12.05	12.05	12.05
Transfer during the period / year	-	-	-	-
<b>Balance as at the end of the period / year</b>	<b>12.05</b>	<b>12.05</b>	<b>12.05</b>	<b>12.05</b>
<b>Surplus/(Deficit) in the Statement of Profit and Loss****</b>				
Balance as per last financial statements	3,005.91	2,475.49	2,241.51	1,819.93
Add: Profit for the period / year	441.74	535.33	265.20	447.12
Add: Other Comprehensive Income				
Re-measurement of defined benefit obligations (net of tax)	(11.33)	(6.17)	(8.23)	(5.26)
Cash flow hedging reserve (net of tax)	(43.47)	1.26	29.52	20.65
	3,392.85	3,005.91	2,528.00	2,282.44
Less: Appropriations				
Share issue Expenses written off	-	-	52.51	-
Dividend / Interim Dividend	45.13	-	-	33.85
Dividend distribution tax	9.28	-	-	11.90
Reversal of dividend distribution tax*	-	-	-	(4.82)
	<b>54.41</b>	<b>-</b>	<b>52.51</b>	<b>40.93</b>
	<b>3,338.44</b>	<b>3,005.91</b>	<b>2,475.49</b>	<b>2,241.51</b>
<b>TOTAL</b>	<b>3,438.31</b>	<b>3,198.90</b>	<b>2,732.33</b>	<b>2,495.78</b>

\* The reversal of dividend distribution tax during the previous year represents dividend distribution tax paid by the subsidiary company on dividend paid to the Company during the previous year. The Company has taken credit of the same while paying the dividend distribution tax on dividend paid during the previous year.

\*\* Securities premium account is used to record the premium on issue of equity shares. The same is utilised in accordance with the provisions of The Companies Act, 2013

\*\*\*The Share option outstanding account is to be utilised for the purpose of issuance of Equity shares under Employee Stock Option Plan.

\*\*\*\* Retained earnings and General Reserve are to be utilised for General purpose.



**UNIPARTS INDIA LIMITED**

**Annexure VI : Notes to Restated Consolidated Financial Information**

(All amounts in millions of INR, unless stated otherwise)

**14. Borrowings**

Particulars	As at September 30, 2018	As at March 31, 2018	As at March 31, 2017 Proforma Ind AS	As at March 31, 2016 Proforma Ind AS
<b>Non-current borrowings</b>				
<b>Term Loans</b>				
Rupee Loan from Banks (secured) (Refer Note 14(a))	0.15	0.15	1.09	106.25
Rupee Loan from Others (Secured) (Refer Note 14(a))	0.59	0.36	3.38	5.52
Foreign Currency Loan from Banks (Refer Note 14(a))	218.81	241.14	172.38	186.08
Foreign Currency Loan from Others	1.14	1.33	1.82	0.34
<b>Total</b>	<b>220.70</b>	<b>242.98</b>	<b>178.67</b>	<b>298.19</b>
<b>Current borrowings</b>				
Rupee Loan from Banks (Secured) (Refer Note 14(a))	0.48	0.94	0.85	75.38
Rupee Loan from Others (Secured)(Refer Note 14(a))	0.05	0.56	1.06	2.12
Foreign Currency Loan from Banks (Refer Note 14(a))	117.76	122.71	137.68	54.19
Foreign Currency Loan from others (secured)	0.61	0.50	0.50	1.96
Bill discounting with Bank	33.58	37.87	29.77	21.33
Working capital loans : (Refer Note 14(a))				
Foreign Currency Loans	1,597.96	1,299.39	1,082.49	1,064.11
Revolving Credit Facility/Lines of Credit	949.13	706.30	466.84	563.15
Indian Rupee Loan	210.96	60.00	50.00	223.50
<b>Total</b>	<b>2,910.53</b>	<b>2,228.27</b>	<b>1,769.19</b>	<b>2,005.74</b>
Less: Amount disclosed in other current financial liabilities	118.90	124.71	140.09	133.65
<b>Total</b>	<b>2,791.63</b>	<b>2,103.56</b>	<b>1,629.10</b>	<b>1,872.09</b>
<b>TOTAL</b>	<b>3,012.33</b>	<b>2,346.54</b>	<b>1,807.77</b>	<b>2,170.28</b>

UNIPARTS INDIA LIMITED  
Annexure VI : Notes to Restated Consolidated Financial Information  
(All amounts in millions of INR, unless stated otherwise)

14 (a) Details of Borrowings (Excluding Bill discounting with Bank)

S.No.	Nature of Loan	Name of Lender	Amount Outstanding as at 30th September, 2018	Nature of Securities	Interest Rate (Per Annum)	Tenure of Repayment
1	Vehicle Loan	Kotak Mahindra Prime Ltd.	0.64	This loan is secured against hypothecation of Cars	9.9%	This loan is repayable in 60 equal installments starting from the date of sanction
2	Term Loan (Foreign Currency)	IndusInd Bank Ltd.	40.15	This loan is secured against (i) First pari-passu charge (with Kotak Mahindra Bank and working capital lenders) by way of hypothecation on all existing and future moveable fixed assets, (ii) Equitable mortgage by way of first pari-passu charge (with Kotak Mahindra Bank and working capital lenders) over the land and building situated at B208, A1&2, Phase II, Noida, UP, (iii) First pari-passu charge (with Kotak Mahindra Bank and working capital lenders) over the land and building situated at C140 & D126A, Phase V, Focal Point, Ludhiana, Punjab, India, (iv) First pari-passu charge (with Kotak Mahindra Bank and working capital lenders) on the Apartment # K-0401, 4th Floor, Tower K, Phase IV, Central Park-1, Gurgaon owned by Mr. Gurdeep Soni (KMP) and Mrs. Pamela Soni (Relative of KMP) and (v) Personal guarantees of Mr. Gurdeep Soni (KMP) and Mr. Paramjit Singh Soni (KMP), Directors of the Company.	@ 6.45% p.a on outstanding USD notional, monthly	Moratorium of 7 months from the date of drawdown and repayable in 53 equal monthly installments
3	Term Loan (Foreign Currency)	Kotak Mahindra Bank Ltd.	198.89	This loan is secured against (i) First pari-passu charge on all existing and future moveable fixed assets excluding vehicle specifically financed by other lenders of the borrowers, (ii) Equitable mortgage charge over two properties, including land and building belonging to the borrowers situated at C140, Focal point, Ludhiana and plot no. D 126A, focal point Ludhiana, (iii) Equitable mortgage charge over residential flat belonging to Pamela Soni (Relative of KMP) & Gurdeep Soni (KMP) Situated at central park, Gurgaon and (iv) Personal guarantees of Mr. Gurdeep Soni (KMP) and Mr. Paramjit Singh Soni (KMP), Directors of the Company.	@ 4.00% ~ 4.50% p.a on outstanding USD notional, monthly	Moratorium of 6 months from the date of drawdown and repayable in 36 equal monthly installments
4	Vehicle Loan	Axis Bank Limited	0.63	This loan is secured against hypothecation of Car	9.75%	This loan is repayable in 36 equal installments starting from the date of sanction
5	Term Loan	JP Morgan Chase	50.03	This loan is secured by (i) substantially all assets of the Uniparts USA Ltd (ii) Corporate Guarantee of Uniparts Olsen Inc.	Interest is due monthly at a rate of 2.25% plus an adjusted LIBOR	Repayable with fixed monthly payments of Rs. 390,660 through March 24, 2021
6	Term Loan	Wells Fargo Equipment Finance	1.75	This loan is secured by Equipment financed	5.29%	Repayable with fixed monthly payments of Rs. 51,176, through June, 2021
7	Term Loan	JP Morgan Chase	47.48	This loan is secured by (i) substantially all assets of the Uniparts Olsen Inc. and (iii) Corporate Guarantee of Uniparts USA Limited.	Interest is due monthly at a rate of 2.00% plus an adjusted LIBOR.	Repayable with fixed monthly payments of Rs. 561,574 through March, 2020, Rs. 483,898 through March, 2021, Rs. 407,328 through March 2022 and Rs. 281,275 through March, 2024. The balance as of each March 24 will be amortized over a 60 month period. All interest and principal is payable in full at the end of the 60 month term.
8	Working Capital Loan (Indian Rupee)	RBL Bank	197.97	This loan is secured against (i) First pari-passu charge way of hypothecation on entire current assets inclusive of stock and book debts, both present and future, (ii) First pari-passu charge way of hypothecation on entire moveable fixed assets inclusive of stock and book debts, both present and future, (iii) First pari-passu charge by way of mortgage on properties situated at B-208, A1 & A2, Industrial Area, Phase-II, Noida.	Ranges from 5.00% to 6.95%	Repayable on Demand or within 180 Days
9	Working Capital Loan (Indian Rupee)	DBS Bank Ltd.	10.00	This loan is secured against (i) First pari-passu charge on all present and future stocks and receivables and movable fixed assets of the company, (ii) First pari-passu charge vide equitable mortgage of land and building situated at B-208/A1 & A2, Phase II, Noida (UP), (iii) Personal guarantees of Mr. Gurdeep Soni (KMP) and Mr. Paramjit Singh Soni (KMP)	Ranges from 5.00% to 6.95%	Repayable on Demand or within 180 Days
10	Working Capital (Indian Rupee)	Kotak Mahindra Bank Ltd.	2.99	This loan is secured against (i) First pari-passu charge on all existing and future current assets of the borrower to be shared with other working capital bankers of the borrower, (ii) First pari-passu charge on all existing and future moveable fixed assets (excluding vehicle specifically financed by other lenders) of the Borrower (iii) Equitable mortgage by way of first pari-passu charge over the land and building situated at B208, A1&2, Phase II, Noida, UP and (iv) Personal guarantees of Mr. Gurdeep Soni (KMP) and Mr. Paramjit Singh Soni (KMP), Directors of the Company.	Ranges from 5.00% to 6.95%	Repayable on Demand or within 180 Days
11	Working Capital Loan (Foreign Currency)	Citibank	715.85	This loan is secured against (i) First pari-passu charge on present and future current assets, stocks and book debts of the borrower, (ii) First pari-passu charge on all the unencumbered moveable fixed assets of the company including land and building situated at B-208, A1 & A2, Industrial Area, Phase-II, Noida, (iii) Personal guarantees of Mr. Gurdeep Soni (KMP) and Mr. Paramjit Soni (KMP), (iv) Lien on the units of Real Estate mutual Fund (Kotak Alternate Opportunities (India) Fund in the name of Mr. Gurdeep Soni (KMP) and Paramjit Singh Soni (KMP) (v) Cash margins of 10% for sight LCs and 10% for bank guarantees, (iv) Demand promissory note and letter of continuity, (v) Drawing power will be calculated as per the internal guidelines of the Bank. No drawing power will be assigned to receivables from group entities.	Ranges from LIBOR+100 bps to 300 bps	Repayable on Demand or within 180 Days

UNIPARTS INDIA LIMITED

Annexure VI : Notes to Restated Consolidated Financial Information

(All amounts in millions of INR, unless stated otherwise)

12	Working Capital Loan (Foreign Currency)	Kotak Mahindra Bank Ltd.	355.47	This loan is secured against (i) First pari-passu charge on all existing and future current assets of the Borrower, to be shared with other working capital bankers of the Borrower, (ii) First pari-passu charge on all existing and future moveable fixed assets (excluding vehicle specifically financed by other lenders) of the Borrower., (iii) Mortgage by way of first pari-passu charge over land and building belonging to the borrower situated at B-208/A1 & A2, Phase II, Noida (UP)	Ranges from LIBOR+100 bps to 300 bps	Repayable on Demand or within 180 Days
13	Working Capital Loan (Foreign Currency)	DBS Bank Ltd.	320.71	This loan is secured against (i) First pari-passu charge on all present and future stocks and receivables and movable fixed assets of the company, (ii) First pari-passu charge vide equitable mortgage of land and building situated at B-208/A1 & A2, Phase II, Noida (UP), (iii) Personal guarantees of Mr. Gurdeep Soni (KMP) and Mr. Paramjit Singh Soni (KMP)	Ranges from LIBOR+100 bps to 300 bps	Repayable on Demand or within 180 Days
14	Working Capital Loan (Foreign Currency)	Citibank	205.93	This loan is secured against (i) First exclusive charge on present and future stocks and book debts of the borrower, (ii) First exclusive charge by way of equitable mortgage on land and building located at 142A/30-142A/51 NSEZ, (iii) corporate guarantee of Uniparts India Limited and (iv) Demand promissory note and letter of continuity	Ranges from LIBOR+100 bps to 300 bps	Repayable on Demand or within 180 Days
15	Revolving Credit Loan (Foreign Currency)	JP Morgan Chase	521.32	The Loan collateralised by substantially all asset of Uniparts USA Ltd., cross collateralised with the term loan at the bank. This line is secured by a corporate guarantee by Uniparts Olsen Inc.	Floating Rate i.e. Interest @ 3.00% to 4.00% p.a.	Repayable on Demand or within 365 Days
16	Revolving Credit Loan (Foreign Currency)	JP Morgan Chase	427.83	The Loan collateralised by substantially all asset of Uniparts Olsen Inc., cross collateralised with the term loan at the bank. This line is secured by a corporate guarantee by Uniparts USA Ltd.	Floating Rate i.e. Interest @ 3.00% to 4.00% p.a.	Repayable on Demand or within 365 Days

UNIPARTS INDIA LIMITED

Annexure VI : Notes to Restated Consolidated Financial Information

(All amounts in millions of INR, unless stated otherwise)

15. Other financial liabilities

Particulars	As at September 30, 2018	As at March 31, 2018	As at March 31, 2017 Proforma Ind AS	As at March 31, 2016 Proforma Ind AS
<b>Other current financial liabilities at amortised cost</b>				
Current maturities of long term loan				
Secured	118.90	124.71	140.09	133.65
Unsecured	-	-	-	-
<b>Total</b>	<b>118.90</b>	<b>124.71</b>	<b>140.09</b>	<b>133.65</b>

16. Income Tax & Deferred Tax

The major components of income tax expense for the period ended September 30, 2018 and years ended March 31, 2018 March 31, 2017 and March 31, 2016 are:

Statement of profit and loss

Particulars	For the Period ended September 30, 2018	For the year ended March 31, 2018	For the year ended March 31, 2017 Proforma Ind AS	For the year ended March 31, 2016 Proforma Ind AS
Current Tax (Net of MAT Credit)	121.05	195.15	100.09	137.13
Deferred Tax	25.77	(37.88)	9.14	(0.29)
<b>Tax expense reported in the statement of profit and loss</b>	<b>146.82</b>	<b>157.27</b>	<b>109.23</b>	<b>136.84</b>

Other comprehensive income (OCI)

Particulars	For the Period ended September 30, 2018	For the year ended March 31, 2018	For the year ended March 31, 2017 Proforma Ind AS	For the year ended March 31, 2016 Proforma Ind AS
<b>Deferred tax related to items recognised in OCI</b>				
Tax effect on net (loss)/gain on revaluation of cash flow hedges	(22.25)	0.67	15.38	-
Tax effect on net (loss)/gain on re-measurement of defined benefit plans	(5.80)	(2.90)	(2.08)	(0.56)
<b>Tax charged to OCI</b>	<b>(28.05)</b>	<b>(2.23)</b>	<b>13.30</b>	<b>(0.56)</b>

Reconciliation of tax expenses and the accounting profit

Particulars	For the Period ended September 30, 2018	For the year ended March 31, 2018	For the year ended March 31, 2017 Proforma Ind AS	For the year ended March 31, 2016 Proforma Ind AS
Accounting profit before tax from operations	601.96	706.24	395.07	617.50
Applicable Tax Rate	34.94%	34.61%	34.61%	34.61%
Income tax expense calculated at applicable tax rate	210.35	244.41	136.73	213.71
Tax effect of :				
Exempted Income	(13.08)	(20.33)	(16.14)	(34.85)
Deductions u/s 80	(0.17)	(1.90)	(1.05)	(1.35)
Expenses disallowed	8.19	19.75	8.19	0.70
Adjustment of Stock u/s 145A	-	18.04	4.20	(0.11)
OCI Adjustments	(5.12)	12.28	(0.46)	(0.71)
MAT Credit	(13.40)	(13.63)	(20.62)	(33.55)
Differential Tax Rate under various jurisdiction for Subsidiaries Companies	(65.71)	(65.54)	(11.19)	(9.72)
Others	-	2.06	0.45	3.01
<b>Current Tax Provision (A)</b>	<b>121.05</b>	<b>195.15</b>	<b>100.09</b>	<b>137.13</b>
Incremental deferred tax liability on Account of timing difference	15.03	(47.68)	18.49	(12.86)
Incremental deferred tax Assets on Account of timing difference	10.74	9.80	(9.34)	12.57
<b>Deferred Tax Provision (B)</b>	<b>25.77</b>	<b>(37.88)</b>	<b>9.14</b>	<b>(0.29)</b>
<b>Total Tax Expenses Recognised (A+B)</b>	<b>146.82</b>	<b>157.27</b>	<b>109.23</b>	<b>136.84</b>
<b>Effective Tax Rate</b>	<b>24.39%</b>	<b>22.27%</b>	<b>27.65%</b>	<b>22.16%</b>

UNIPARTS INDIA LIMITED

Annexure VI : Notes to Restated Consolidated Financial Information

(All amounts in millions of INR, unless stated otherwise)

Deferred tax

Particulars	As at September 30, 2018	As at March 31, 2018	As at March 31, 2017 Proforma Ind AS	As at March 31, 2016 Proforma Ind AS
<b>DEFERRED TAX LIABILITIES:</b>				
<b>On account of timing difference in</b>				
A] Carrying amount of Assets as per I.T Act, 2961 and Companies Act, 2013	204.69	200.02	196.35	196.17
B] Fair valuation of cash flow hedges	(22.25)	0.67	15.38	-
<b>On account of Overseas Subsidiaries</b>				
A] Deferred Tax Liabilities	134.20	110.03	145.85	130.91
<b>Gross Deferred Tax Liabilities</b>	<b>316.64</b>	<b>310.72</b>	<b>357.58</b>	<b>327.08</b>
<b>DEFERRED TAX ASSETS:</b>				
<b>On account of timing difference in</b>				
A] Disallowances u/s 43B of I.T. Act, 1961	57.28	62.22	50.89	43.66
B] Unabsorbed Depreciation and Business Losses	-	-	-	-
C] Adjustment of Stock U/s 145A	-	-	18.23	14.04
<b>On account of Overseas Subsidiaries</b>				
A] Deferred Tax Assets	-	-	-	-
<b>Gross Deferred Tax Assets</b>	<b>57.28</b>	<b>62.22</b>	<b>69.12</b>	<b>57.70</b>
<b>TOTAL</b>	<b>259.36</b>	<b>248.50</b>	<b>288.46</b>	<b>269.38</b>

17. Provisions

Particulars	As at September 30, 2018	As at March 31, 2018	As at March 31, 2017 Proforma Ind AS	As at March 31, 2016 Proforma Ind AS
<b>Non-current</b>				
Provision for gratuity (Refer Note 34)	122.13	93.70	69.15	50.47
Provision for leave entitlement (Refer Note 34)	22.92	19.27	14.16	11.17
<b>Total</b>	<b>145.05</b>	<b>112.97</b>	<b>83.31</b>	<b>61.64</b>
<b>Current</b>				
Provision for gratuity (Refer Note 34)	32.08	33.68	31.53	29.90
Provision for leave entitlement (Refer Note 34)	18.90	21.65	19.84	15.71
<b>Total</b>	<b>50.98</b>	<b>55.33</b>	<b>51.37</b>	<b>45.61</b>
<b>TOTAL</b>	<b>196.03</b>	<b>168.30</b>	<b>134.68</b>	<b>107.25</b>

**UNIPARTS INDIA LIMITED**  
**Annexure VI : Notes to Restated Consolidated Financial Information**  
(All amounts in millions of INR, unless stated otherwise)

**18. Other liabilities**

Particulars	As at September 30, 2018	As at March 31, 2018	As at March 31, 2017 Proforma Ind AS	As at March 31, 2016 Proforma Ind AS
<b>Non-current</b>				
Deferred Rent	8.90	12.22	19.14	25.25
Deferred Gain-Leaseback	4.49	6.24	10.60	15.30
Deferred Government Grant**	4.14	4.29	-	-
<b>Total</b>	<b>17.53</b>	<b>22.75</b>	<b>29.74</b>	<b>40.55</b>
<b>Current</b>				
Trade Deposits and Advances*	0.58	0.90	1.03	0.19
Provision for Expenses	96.13	62.98	38.02	30.58
Employee Benefits Payable	164.20	132.96	168.35	127.50
Temporary Overdraft from Banks	36.92	69.56	30.26	26.09
Deferred Government Grant**	0.22	0.07	-	-
Statutory Dues Payable	40.82	25.86	27.68	21.93
<b>Total</b>	<b>338.87</b>	<b>292.33</b>	<b>265.34</b>	<b>206.29</b>
<b>TOTAL</b>	<b>356.40</b>	<b>315.08</b>	<b>295.08</b>	<b>246.84</b>

\* Recognised as revenue upon satisfaction of performance obligation in immediate next reporting period.

\*\* Government grants include grants and subsidies for investments in fixed assets. There are no unfulfilled conditions or contingencies attached to these grants.

**19. Trade payables**

Particulars	As at September 30, 2018	As at March 31, 2018	As at March 31, 2017 Proforma Ind AS	As at March 31, 2016 Proforma Ind AS
Total outstanding dues to micro enterprises and small enterprises (refer note 35)*	6.25	-	-	-
Total outstanding dues other than to micro enterprises and small enterprises	1,052.31	875.48	605.10	578.46
<b>TOTAL</b>	<b>1,058.56</b>	<b>875.48</b>	<b>605.10</b>	<b>578.46</b>

\* The Company has concluded the exercise for identification of micro enterprises and small enterprises after March 31, 2018, therefore the comparative figures for years ended March 31, 2018, March 31, 2017 and March 31, 2016 are not available.

**Break up of financial liabilities carried at amortised cost**

Particulars	As at September 30, 2018	As at March 31, 2018	As at March 31, 2017 Proforma Ind AS	As at March 31, 2016 Proforma Ind AS
Non-current borrowings (Refer Note 14)	220.70	242.98	178.67	298.19
Current borrowings (Refer Note 14)	2,791.63	2,103.56	1,629.10	1,872.09
Other financial liabilities (Refer Note 15)	118.90	124.71	140.09	133.65
Trade payables (Refer Note 19)	1,052.31	875.48	605.10	578.46
<b>TOTAL</b>	<b>4,183.53</b>	<b>3,346.74</b>	<b>2,552.96</b>	<b>2,882.39</b>

**UNIPARTS INDIA LIMITED**  
**Annexure VI : Notes to Restated Consolidated Financial Information**  
(All amounts in millions of INR, unless stated otherwise)

**20. Revenue from operations**

Particulars	For the Period ended September 30, 2018	For the year ended March 31, 2018	For the year ended March 31, 2017 Proforma Ind AS	For the year ended March 31, 2016 Proforma Ind AS
<b>Revenue from Operations</b>				
<b>Sale of Products</b>				
Sale of Finished Goods [Net of returns, rebate etc.]	4,944.68	8,131.96	6,779.69	7,535.23
Sale of Scrap	118.15	173.49	129.60	128.97
<b>Sale of Services</b>				
Job Work Receipts	-	-	0.01	-
	<b>5,062.83</b>	<b>8,305.45</b>	<b>6,909.30</b>	<b>7,664.20</b>
<b>Other Operating Revenues</b>				
Export Incentives	94.28	156.41	122.17	131.00
	<b>94.28</b>	<b>156.41</b>	<b>122.17</b>	<b>131.00</b>
<b>Revenue from Operations (net)</b>	<b>5,157.11</b>	<b>8,461.86</b>	<b>7,031.47</b>	<b>7,795.20</b>

Consequent to introduction of Goods and Service Tax ("GST") with effect from 1 July 2017, central excise and value added tax have been subsumed into GST. In accordance with Ind AS 18, GST is not considered a part of revenue unlike excise duties which used to be included in revenue in period before 1 July 2017. Accordingly, the figures for the year ending March 31, 2018 are strictly not comparable with the previous fiscal year(s).

**21. Other income**

Particulars	For the Period ended September 30, 2018	For the year ended March 31, 2018	For the year ended March 31, 2017 Proforma Ind AS	For the year ended March 31, 2016 Proforma Ind AS
<b>Interest Income</b>				
Interest	1.75	1.89	4.58	8.44
<b>Others</b>				
Profit on sale of investment	-	-	0.13	-
Profit on sale and lease back	-	-	4.41	3.53
Lease Receipts	-	1.60	-	-
Miscellaneous Receipts	2.14	5.81	11.60	8.26
<b>TOTAL</b>	<b>3.89</b>	<b>9.30</b>	<b>20.72</b>	<b>20.23</b>

**22. Cost of raw materials and components consumed**

Particulars	For the Period ended September 30, 2018	For the year ended March 31, 2018	For the year ended March 31, 2017 Proforma Ind AS	For the year ended March 31, 2016 Proforma Ind AS
Inventories at the beginning of the year	520.11	340.93	326.52	385.95
Add: Purchases	2,273.71	3,548.54	2,403.74	2,754.55
	<b>2,793.82</b>	<b>3,889.47</b>	<b>2,730.26</b>	<b>3,140.50</b>
Less: Inventories at the end of the year	617.41	520.11	340.93	326.52
<b>Cost of raw materials and components consumed</b>	<b>2,176.41</b>	<b>3,369.36</b>	<b>2,389.33</b>	<b>2,813.98</b>

**23. Purchase of stock-in-trade**

Particulars	For the Period ended September 30, 2018	For the year ended March 31, 2018	For the year ended March 31, 2017 Proforma Ind AS	For the year ended March 31, 2016 Proforma Ind AS
Linkage Parts and Components for off-highway vehicles	-	-	1.37	3.03
<b>TOTAL</b>	<b>-</b>	<b>-</b>	<b>1.37</b>	<b>3.03</b>

**UNIPARTS INDIA LIMITED**
**Annexure VI : Notes to Restated Consolidated Financial Information**  
 (All amounts in millions of INR, unless stated otherwise)

**24. Changes in the inventories**

Particulars	For the Period ended September 30, 2018	For the year ended March 31, 2018	For the year ended March 31, 2017 Proforma Ind AS	For the year ended March 31, 2016 Proforma Ind AS
<b>(Increase)/Decrease in Stocks:</b>				
<b>Stocks at close:</b>				
Finished Goods	1,661.51	1,298.71	945.08	1,124.89
Work-in-Progress	1,105.10	848.36	658.84	503.88
Scrap	4.41	7.12	2.27	4.48
	<b>2,771.02</b>	<b>2,154.19</b>	<b>1,606.19</b>	<b>1,633.25</b>
<b>Less: Stocks at commencement:</b>				
Finished Goods	1,298.71	945.08	1,124.89	964.01
Work-in-Progress	848.36	658.84	503.88	613.64
Scrap	7.12	2.27	4.48	3.01
	<b>2,154.19</b>	<b>1,606.19</b>	<b>1,633.25</b>	<b>1,580.66</b>
<b>TOTAL</b>	<b>(616.83)</b>	<b>(548.01)</b>	<b>27.06</b>	<b>(52.59)</b>

**25. Employee benefit expenses**

Particulars	For the Period ended September 30, 2018	For the year ended March 31, 2018	For the year ended March 31, 2017 Proforma Ind AS	For the year ended March 31, 2016 Proforma Ind AS
Salaries and Wages (Refer Note 34)	982.90	1,643.24	1,465.04	1,490.66
Contribution to Provident and other Funds	31.54	57.39	54.01	48.32
Expense on Employee Stock Option Scheme	0.02	0.29	0.77	1.49
Staff Welfare Expenses	39.09	68.66	61.98	55.29
<b>TOTAL</b>	<b>1,053.55</b>	<b>1,769.58</b>	<b>1,581.81</b>	<b>1,595.76</b>

**26. Finance cost**

Particulars	For the Period ended September 30, 2018	For the year ended March 31, 2018	For the year ended March 31, 2017 Proforma Ind AS	For the year ended March 31, 2016 Proforma Ind AS
Interest	59.08	72.60	71.80	85.89
Bill Discounting Charges	6.88	9.12	6.27	7.70
<b>Other Borrowing Costs:</b>				
Bank Charges	4.26	8.60	8.48	6.89
<b>TOTAL</b>	<b>70.22</b>	<b>90.32</b>	<b>86.55</b>	<b>100.48</b>

**27. Depreciation and amortization expense**

Particulars	For the Period ended September 30, 2018	For the year ended March 31, 2018	For the year ended March 31, 2017 Proforma Ind AS	For the year ended March 31, 2016 Proforma Ind AS
Depreciation of Tangible Assets	108.06	196.59	185.00	171.90
Amortization of Intangible Assets	3.00	11.94	12.66	12.99
<b>TOTAL</b>	<b>111.06</b>	<b>208.53</b>	<b>197.66</b>	<b>184.89</b>



**UNIPARTS INDIA LIMITED**
**Annexure VI : Notes to Restated Consolidated Financial Information**

(All amounts in millions of INR, unless stated otherwise)

**28. Other expenses**

Particulars	For the Period ended September 30, 2018	For the year ended March 31, 2018	For the year ended March 31, 2017 Proforma Ind AS	For the year ended March 31, 2016 Proforma Ind AS
Stores, Spares and Tools Consumed	322.77	584.47	466.46	511.44
Sub-contracting Expenses	484.35	844.81	644.50	670.98
Power, Fuel and Water	185.03	338.08	290.03	284.73
Cartage, Freight and Forwarding	228.46	378.64	282.73	280.48
Air Freight	178.87	205.15	58.29	69.76
Rent	72.60	157.68	159.44	128.65
Rates and Taxes	17.62	27.63	27.15	22.04
Travelling and Conveyance	24.27	42.64	42.39	33.53
Communication	7.70	16.21	16.04	15.19
Printing and Stationery	4.48	6.32	5.90	6.08
Insurance	20.59	33.02	40.24	43.71
<b>Repairs and Maintenance:</b>				
Building	15.45	23.35	27.67	28.68
Plant and Machinery	55.68	96.83	97.32	108.30
Others	49.71	85.68	80.53	87.36
Office Maintenance	10.60	17.63	16.31	14.25
Vehicle Repairs and Maintenance	6.13	12.12	10.61	11.06
Advertisement, Publicity and Sales Promotion	3.89	10.14	7.06	4.97
Commission and Discount	1.88	4.30	7.79	7.82
Legal and Professional Charges	18.24	44.73	34.59	53.65
Directors Sitting Fees	0.58	0.80	1.10	0.99
Director Commission	-	1.10	-	-
Payment to Auditors (Refer details below)	11.29	13.23	13.08	11.24
Exchange Differences (net)	38.81	(131.93)	(78.67)	17.59
Bad Debts	-	2.88	0.07	7.44
Provision for Doubtful Debts	-	0.48	0.95	-
Staff Recruitments	0.88	2.65	2.21	7.54
Loss on sale of Fixed Assets (net)	0.56	(2.09)	4.06	1.00
Donation and charity	0.21	3.00	0.36	5.05
Contribution towards CSR	-	6.00	6.20	4.05
Miscellaneous	4.00	5.55	2.48	8.45
<b>TOTAL</b>	<b>1,764.63</b>	<b>2,831.10</b>	<b>2,266.87</b>	<b>2,446.03</b>

**Payment to Auditors:**

Particulars	For the Period ended September 30, 2018	For the year ended March 31, 2018	For the year ended March 31, 2017 Proforma Ind AS	For the year ended March 31, 2016 Proforma Ind AS
<b>As Auditors:</b>				
Audit Fee	10.92	12.39	10.97	10.01
Tax Audit Fee	-	0.07	0.37	0.37
<b>In Other Capacity:</b>				
Taxation Matters	-	0.04	1.04	0.24
Out of Pocket Expenses	0.37	0.73	0.70	0.62
Audit fees includes INR 0.5 million for the year ended March 31, 2016 paid for other services rendered in connection with proposed IPO of the Company.				
<b>TOTAL</b>	<b>11.29</b>	<b>13.23</b>	<b>13.08</b>	<b>11.24</b>

**UNIPARTS INDIA LIMITED**

**Annexure VI : Notes to Restated Consolidated Financial Information**  
(All amounts in millions of INR, unless stated otherwise)

**29. Computation of earning per share (EPS)**

Basic EPS amounts are calculated by dividing the profit for the period / year attributable to equity share holders of the parent by the weighted average number of Equity shares outstanding during the period / year.

Diluted EPS amounts are calculated by dividing the profit attributable to equity share holders of the parent by the weighted average number of Equity shares outstanding during the period / year plus the weighted average number of Equity shares that would be issued on conversion of all the dilutive potential Equity shares into Equity shares.

The following reflects the income and share data used in the basic and diluted EPS computations:

Particulars	For the Period ended September 30, 2018	For the year ended March 31, 2018	For the year ended March 31, 2017 Proforma Ind AS	For the year ended March 31, 2016 Proforma Ind AS
Computation of Profit (Numerator)				
Net Profit after Tax as per the Statement of Profit & Loss attributable to Equity Shareholders	441.74	535.33	265.20	447.12
Computation of Weighted Average Number of Shares (Denominator)				
Number of Shares outstanding at the Beginning of the year	45,133,758	45,133,758	45,133,758	45,133,758
<b>Adjusted Weighted Average number of Equity Shares for calculating Diluted EPS</b>	<b>45,133,758</b>	<b>45,133,758</b>	<b>45,133,758</b>	<b>45,133,758</b>
Less: Shares Issued to Uniparts ESOP Trust	1,027,200	1,027,200	1,027,200	1,027,200
<b>Adjusted Weighted Average number of Equity Shares for calculating Basic EPS</b>	<b>44,106,558</b>	<b>44,106,558</b>	<b>44,106,558</b>	<b>44,106,558</b>
Computation of EPS - Basic (in INR)	10.02	12.14	6.01	10.14
Computation of EPS - Diluted (in INR)	9.79	11.86	5.88	9.91

**UNIPARTS INDIA LIMITED**

**Annexure VI : Notes to Restated Consolidated Financial Information**  
(All amounts in millions of INR, unless stated otherwise)

**30. Components of other comprehensive income (OCI)**

The disaggregation of changes to OCI by each type of reserve in equity is shown below:

**During the period ended September 30, 2018**

<b>Particulars</b>	<b>Cash flow hedge reserve</b>	<b>Foreign currency translation differences</b>	<b>Retained earnings</b>	<b>Total</b>
Currency forward contracts	1.25	-	-	1.25
Reclassified to statement of profit or loss	(1.25)	-	-	(1.25)
Gain/(loss) on FVTOCI financial assets (net of tax)	(43.47)	-	-	(43.47)
Foreign exchange translation difference	-	(93.14)	-	(93.14)
Re-measurement gains (losses) on defined benefit plans (net of tax)	-	-	(11.33)	(11.33)
<b>Total</b>	<b>(43.47)</b>	<b>(93.14)</b>	<b>(11.33)</b>	<b>(147.94)</b>

**During the year ended March 31, 2018**

<b>Particulars</b>	<b>Cash flow hedge reserve</b>	<b>Foreign currency translation differences</b>	<b>Retained earnings</b>	<b>Total</b>
Currency forward contracts	29.52	-	-	29.52
Reclassified to statement of profit or loss	(29.52)	-	-	(29.52)
Gain/(loss) on FVTOCI financial assets (net of tax)	1.25	-	-	1.25
Foreign exchange translation difference	-	(64.14)	-	(64.14)
Re-measurement gains (losses) on defined benefit plans (net of tax)	-	-	(6.17)	(6.17)
<b>Total</b>	<b>1.25</b>	<b>(64.14)</b>	<b>(6.17)</b>	<b>(69.06)</b>

**During the year ended March 31, 2017-Proforma Ind AS**

<b>Particulars</b>	<b>Cash flow hedge reserve</b>	<b>Foreign currency translation differences</b>	<b>Retained earnings</b>	<b>Total</b>
Currency forward contracts	20.65	-	-	20.65
Reclassified to statement of profit or loss	(20.65)	-	-	(20.65)
Gain/(loss) on FVTOCI financial assets (net of tax)	29.52	-	-	29.52
Foreign exchange translation difference	-	1.80	-	1.80
Re-measurement gains (losses) on defined benefit plans (net of tax)	-	-	(8.23)	(8.23)
<b>Total</b>	<b>29.52</b>	<b>1.80</b>	<b>(8.23)</b>	<b>23.08</b>

**During the year ended March 31, 2016 - Proforma Ind AS**

<b>Particulars</b>	<b>Cash flow hedge reserve</b>	<b>Foreign currency translation differences</b>	<b>Retained earnings</b>	<b>Total</b>
Currency forward contracts	17.15	-	-	17.15
Reclassified to statement of profit or loss	(17.15)	-	-	(17.15)
Gain/(loss) on FVTOCI financial assets (net of tax)	20.65	-	-	20.65
Foreign exchange translation difference	-	(80.92)	-	(80.92)
Re-measurement gains (losses) on defined benefit plans (net of tax)	-	-	(5.26)	(5.26)
<b>Total</b>	<b>20.65</b>	<b>(80.92)</b>	<b>(5.26)</b>	<b>(65.53)</b>

**UNIPARTS INDIA LIMITED**

**Annexure VI : Notes to Restated Consolidated Financial Information  
(All amounts in millions of INR, unless stated otherwise)**

31. The consolidated financial statements include results of all the subsidiaries of Uniparts India Limited and interalia their subsidiaries & Associates. The names, country of incorporation or residence, proportion of ownership interest and reporting dates are as under:-

**Subsidiaries**

Name of Company	Principal Activities	Country of Incorporation	Parent's ultimate holding as on			
			As at September 30, 2018	As at March 31, 2018	As at March 31, 2017 Proforma Ind AS	As at March 31, 2016 Proforma Ind AS
- Gripwel Fasteners Private Limited	Manufacturing	India	100%	100%	100%	100%
- Uniparts USA Limited and its wholly owned Subsidiary	Warehousing and Logistics	USA	100%	100%	100%	100%
i. Uniparts Olsen Inc.	Manufacturing	USA	100%*	100%*	100%*	100%*
- Uniparts Europe B.V.	Warehousing and Logistics	Netherlands	100%	100%	100%	100%
- Uniparts India GmbH	Warehousing and Logistics	Germany	100%	100%	100%	100%

\* held through subsidiaries

**Additional information, as required under Schedule III to the Companies Act, 2013, of enterprise consolidated as subsidiary/Associates/Joint Venture.**

Name of the Enterprise	Net Assets i.e. total assets minus total liabilities		Share in Profit or Loss		Share in Other Comprehensive Income		Share in Total Comprehensive Income	
	As % of consolidated net assets	Amount	As % of consolidated profits	Amount	As % of Consolidated Other Comprehensive Income	Amount	As % of Consolidated Total Comprehensive Income	Amount
<b>Parent:</b>								
<b>Uniparts India Limited</b>								
Balance as at September 30, 2018	62.94%	2,445.01	22.24%	98.23	29.68%	(43.90)	18.49%	54.33
Balance as at March 31, 2018	66.87%	2,437.38	28.24%	151.17	6.22%	(4.30)	31.50%	146.87
Balance as at March 31, 2017 - Proforma Ind AS	72.05%	2,290.22	50.49%	133.90	75.24%	17.37	52.47%	151.27
Balance as at March 31, 2016 - Proforma Ind AS	74.46%	2,190.69	59.72%	267.03	-17.56%	11.51	72.99%	278.54
<b>Subsidiaries:</b>								
<b>- Indian</b>								
<b>1. Gripwel Fasteners Private Limited</b>								
Balance as at September 30, 2018	10.53%	409.12	21.29%	94.07	7.36%	(10.88)	28.31%	83.18
Balance as at March 31, 2018	10.18%	371.07	19.46%	104.20	0.53%	(0.37)	22.27%	103.83
Balance as at March 31, 2017 - Proforma Ind AS	8.41%	267.24	18.09%	47.97	23.32%	5.38	18.51%	53.35
Balance as at March 31, 2016 - Proforma Ind AS	7.27%	213.89	12.79%	57.20	-8.09%	5.30	16.38%	62.51

**UNIPARTS INDIA LIMITED**

**Annexure VI : Notes to Restated Consolidated Financial Information  
(All amounts in millions of INR, unless stated otherwise)**

<b>- Foreign</b>									
<b>1. Uniparts USA Limited</b>									
Balance as at September 30, 2018	5.86%	227.58	32.72%	144.53	-	-	-	-	-
Balance as at March 31, 2018	4.18%	152.32	32.40%	173.42	-	-	-	-	-
Balance as at March 31, 2017 - Proforma Ind AS	2.73%	86.89	3.76%	9.97	-	-	-	-	-
Balance as at March 31, 2016 - Proforma Ind AS	2.47%	72.81	15.48%	69.22	-	-	-	-	-
<b>2. Uniparts Olsen Inc.</b>									
Balance as at September 30, 2018	24.80%	963.25	37.15%	164.09	-	-	-	-	-
Balance as at March 31, 2018	22.10%	805.65	8.73%	46.74	-	-	-	-	-
Balance as at March 31, 2017	19.76%	628.06	20.62%	54.70	-	-	-	-	-
Balance as at March 31, 2016 - Proforma Ind AS	19.51%	573.92	13.41%	59.96	-	-	-	-	-
<b>3. Uniparts Europe B.V.</b>									
Balance as at September 30, 2018	-0.99%	(38.31)	0.09%	0.39	-	-	-	-	-
Balance as at March 31, 2018	-1.01%	(36.72)	0.01%	0.05	-	-	-	-	-
Balance as at March 31, 2017 - Proforma Ind AS	-1.00%	(31.67)	0.05%	0.14	-	-	-	-	-
Balance as at March 31, 2016 - Proforma Ind AS	-1.18%	(34.70)	-0.01%	(0.04)	-	-	-	-	-
<b>4. Uniparts India GmbH</b>									
Balance as at September 30, 2018	1.42%	55.29	5.17%	22.86	-	-	-	-	-
Balance as at March 31, 2018	1.21%	44.04	4.00%	21.41	-	-	-	-	-
Balance as at March 31, 2017 - Proforma Ind AS	0.58%	18.33	-1.43%	(3.78)	-	-	-	-	-
Balance as at March 31, 2016 - Proforma Ind AS	0.54%	15.88	5.61%	25.07	-	-	-	-	-
<b>Adjustments arising out of consolidation</b>									
As at September 30, 2018	-4.57%	(177.41)	-18.66%	(82.43)	62.96%	(93.15)	53.20%		156.30
As at March 31, 2018	-3.53%	(128.64)	7.16%	38.35	93.25%	(64.39)	46.23%		215.57
As at March 31, 2017 - Proforma Ind AS	-3.17%	(106.26)	2.99%	(2.88)	1.44%	0.33	29.02%		83.67
As at March 31, 2016 - Proforma Ind AS	-3.11%	(92.94)	0.03%	(2.48)	125.65%	(82.34)	10.63%		40.54
<b>Total after elimination on account of consolidation-September 30, 2018</b>	100%	3,884.51	100.00%	441.74	100.00%	(147.94)	100%		293.80
<b>Total after elimination on account of consolidation-March 31, 2018</b>	100%	3,645.10	100.00%	535.33	100.00%	(69.06)	100%		466.27
<b>Total after elimination on account of consolidation-March 31, 2017-Proforma Ind AS</b>	100%	3,178.53	100.00%	265.20	100.00%	23.08	100%		288.28
<b>Total after elimination on account of consolidation-March 31, 2016- Proforma Ind AS</b>	100%	2,941.98	100.00%	447.12	100.00%	(65.53)	100%		381.59

UNIPARTS INDIA LIMITED

Annexure VI : Notes to Restated Consolidated Financial Information

(All amounts in millions of INR, unless stated otherwise)

32. Leases

Operating Leases

(a) Operating leases : Company as lessee

The Company has entered into agreements in the nature of lease and license agreements with different lessors/licensors for the purpose of establishment of office premises/residential accommodations etc. These are generally in the nature of operating lease and license. There are no transactions in the nature of sublease. Period of agreements are generally up to nine years and renewal at the options of the lessee. The lease includes escalation clause and the company does not have to incur any dismantling cost while handing over the physical possession of the leasehold property to the lessor.

The lease rentals charged during the period is as under:

Particulars	For the Period ended September 30, 2018	For the year ended March 31, 2018	For the year ended March 31, 2017 Proforma Ind AS	For the year ended March 31, 2016 Proforma Ind AS
Minimum lease payments recognised in the statement of profit and loss during the year	72.08	162.50	164.42	126.14
<b>Total</b>	<b>72.08</b>	<b>162.50</b>	<b>164.42</b>	<b>126.14</b>

The Company has entered into non-cancellable operating leases for building, with lease term 4 years. The Company has an option to extend the lease by mutual consent. The lease includes escalation clause. Future minimum rentals payable under non-cancellable operating leases are as follows:

Particulars	For the Period ended September 30, 2018	For the year ended March 31, 2018	For the year ended March 31, 2017 Proforma Ind AS	For the year ended March 31, 2016 Proforma Ind AS
Minimum lease payments to be recognised in the statement of profit and loss during the year				
Not later than one year	27.13	27.16	55.05	53.33
Later than one year and not later than five years	41.14	53.79	300.50	130.81
Later than five years	-	-	-	-
<b>Total</b>	<b>68.27</b>	<b>80.95</b>	<b>355.55</b>	<b>184.14</b>

Financial Leases

Future minimum rentals payable under non-cancellable finance leases are as follows:

Particulars	For the Period ended September 30, 2018	For the year ended March 31, 2018	For the year ended March 31, 2017 Proforma Ind AS	For the year ended March 31, 2016 Proforma Ind AS
Minimum lease payments to be recognised in the statement of profit and loss				
Not later than one year	-	-	-	1.85
Later than one year and not later than five years	-	-	-	-
Later than five years	-	-	-	-
<b>Total</b>	<b>-</b>	<b>-</b>	<b>-</b>	<b>1.85</b>

UNIPARTS INDIA LIMITED

Annexure VI : Notes to Restated Consolidated Financial Information  
(All amounts in millions of INR, unless stated otherwise)

33. Segment Information and disaggregation of Revenue

The Company operates primarily in the business of manufacturing of Linkage Parts and Components for Off-Highway Vehicles.

Chief Operating Decision Maker (CODM), evaluates the company's performance, based on the analysis of the various performance indicators of the company, the Chief Operating Decision Maker (CODM) has decided that there is no reportable segment for the Company.

Revenue information based on location of the customers

Particulars	For the Period ended September 30, 2018	For the year ended March 31, 2018	For the year ended March 31, 2017 Proforma Ind AS	For the year ended March 31, 2016 Proforma Ind AS
<b>Information in respect of geographical areas</b>				
Segment revenue from external customers				
Within India	796.95	1,346.35	1,170.21	1,059.12
Outside India	4,265.87	6,959.10	5,739.09	6,605.08
(Excluding deemed export)				
<b>Total</b>	<b>5,062.82</b>	<b>8,305.45</b>	<b>6,909.30</b>	<b>7,664.20</b>

The company disaggregate revenue from contracts with customers into categories that depict how the nature, amount, timing and uncertainty of revenue and cash flows are affected by economic factors. The following table illustrates the disaggregation disclosure by primary geographical market, major product line and timing of revenue recognition in accordance with Ind AS 115.

Particulars	For the period ended September 30, 2018	For the year ended March 31, 2018	For the year ended March 31, 2017 Proforma Ind AS	For the year ended March 31, 2016 Proforma Ind AS
<b>Primary geographical markets</b>				
Americas	2,915.67	4,573.39	3,800.79	4,518.59
Asia Pacific	101.39	134.75	117.75	114.81
Europe	874.26	1,663.50	1,276.79	1,291.58
India	693.40	1,193.87	1,057.75	944.64
Japan	228.66	335.07	323.89	436.91
Rest of the World	131.29	231.38	202.72	228.70
<b>Total</b>	<b>4,944.67</b>	<b>8,131.96</b>	<b>6,779.69</b>	<b>7,535.23</b>
Add: Sale of Scrap	118.15	173.49	129.60	128.97
Add: Job Work Receipts	-	-	0.01	-
<b>Total Revenue as shown in Segment Reporting</b>	<b>5,062.82</b>	<b>8,305.45</b>	<b>6,909.30</b>	<b>7,664.20</b>

Major Product line

3PL	2,448.47	4,117.35	3,418.18	3,841.04
FAB	16.31	28.99	20.90	27.08
HYD	13.35	25.60	19.11	15.59
PMP	2,412.78	3,799.94	3,107.58	3,436.55
PTO	42.99	98.74	83.19	87.90
Others	10.77	61.34	130.72	127.06
<b>Total</b>	<b>4,944.67</b>	<b>8,131.96</b>	<b>6,779.69</b>	<b>7,535.23</b>
Add: Sale of Scrap	118.15	173.49	129.60	128.97
Add: Job Work Receipts	-	-	0.01	-
<b>Total Revenue as shown in Segment Reporting</b>	<b>5,062.82</b>	<b>8,305.45</b>	<b>6,909.30</b>	<b>7,664.20</b>

34. Gratuity and other post employment benefits

The following table summarises the components of net benefit expense recognised in the statement of profit and loss and the funded status and amounts recognised in the balance sheet for the gratuity plan.

The principal assumptions used in determining gratuity for the Company's plan is shown below:

Particulars	For the Period ended September 30, 2018	For the year ended March 31, 2018	For the year ended March 31, 2017 Proforma Ind AS	For the year ended March 31, 2016 Proforma Ind AS
Expected Rate of Return on Plan Assets	8.28%	7.68%	6.77%	7.72%
Discounting Rate for Uniparts India Limited	8.28%	7.68%	6.77%	7.72%
Discounting Rate for Gripwel Fasteners Private Limited	8.28%	7.65%	6.77%	7.72%
Salary Escalation rate	9.01%	7.14%	5.00%	4.00%
Rate of Employee Turnover	11.40%	11.40%	15.00%	15.00%
Mortality Rate During Employment	Indian Assured Lives Mortality(2006-08)	Indian Assured Lives Mortality(2006-08)	Indian Assured Lives Mortality(2006-08)	Indian Assured Lives Mortality(2006-08)
Mortality Rate After Employment	N.A.	N.A.	N.A.	N.A.

UNIPARTS INDIA LIMITED

Annexure VI : Notes to Restated Consolidated Financial Information  
(All amounts in millions of INR, unless stated otherwise)

Changes in the present value of the defined benefit obligation recognised in balance sheet are as follows:

Particulars	As at September 30, 2018	As at March 31, 2018	As at March 31, 2017 Proforma Ind AS	As at March 31, 2016 Proforma Ind AS
Present value of obligation as at the beginning of the year	145.27	117.55	95.25	82.33
Interest cost	5.57	7.96	7.35	6.50
Current service cost	7.09	11.11	9.72	9.78
Past Service Cost	-	6.08	-	-
Liability Transferred In/ Acquisitions (Liability Transferred Out/ Divestments)	-	0.01 (0.01)	0.10 (0.10)	-
(Benefit Paid Directly by the Employer)	(2.27)	(6.38)	(5.94)	(8.79)
Actuarial (Gains)/Losses on Obligations - Due to Change in Demographic Assumptions	-	(2.18)	-	-
Actuarial (Gains)/Losses on Obligations - Due to Change in Financial Assumptions	10.60	8.76	7.76	0.64
Actuarial (Gains)/Losses on Obligations - Due to Experience	5.91	2.37	3.41	4.79
<b>Present Value of Benefit Obligation at the End of the Year</b>	<b>172.17</b>	<b>145.27</b>	<b>117.55</b>	<b>95.25</b>

Changes in the fair value of plan assets recognised in the balance sheet are as follows:

Particulars	As at September 30, 2018	As at March 31, 2018	As at March 31, 2017 Proforma Ind AS	As at March 31, 2016 Proforma Ind AS
Opening fair value of plan assets	17.88	16.87	14.87	14.14
Interest Income	0.69	1.14	1.15	1.12
Contributions	-	-	-	-
Benefits paid	-	-	-	-
Return on plan assets, excluding amount recognized in Interest Income -Gain	(0.61)	(0.13)	0.86	(0.39)
<b>Closing fair value of plan assets</b>	<b>17.96</b>	<b>17.88</b>	<b>16.88</b>	<b>14.87</b>

The amounts to be recognised in the Balance Sheet

Particulars	As at September 30, 2018	As at March 31, 2018	As at March 31, 2017 Proforma Ind AS	As at March 31, 2016 Proforma Ind AS
Present value of obligation as at the end of the year	(172.17)	(145.27)	(117.55)	(95.24)
Fair value of plan assets as at the end of the year	17.96	17.88	16.88	14.87
Funded Status (Surplus/ (Deficit))	(154.21)	(127.39)	(100.67)	(80.38)
<b>Net asset / (liability) to be recognised in balance sheet</b>	<b>(154.21)</b>	<b>(127.39)</b>	<b>(100.67)</b>	<b>(80.38)</b>

Net Interest cost (Income/Expense)

Particulars	As at September 30, 2018	As at March 31, 2018	As at March 31, 2017 Proforma Ind AS	As at March 31, 2016 Proforma Ind AS
Present Value of Benefit Obligation at the Beginning of the year (Fair Value of Plan Assets at the Beginning of the year)	145.26 (17.88)	117.56 (16.87)	95.24 (14.87)	82.33 (14.14)
<b>Net Liability/(Asset) at the Beginning</b>	<b>127.38</b>	<b>100.69</b>	<b>80.37</b>	<b>68.19</b>
Interest Cost	5.57	7.96	7.35	6.50
(Interest Income)	(0.69)	(1.14)	(1.15)	(1.12)
<b>Net Interest Cost for Current year</b>	<b>4.88</b>	<b>6.82</b>	<b>6.20</b>	<b>5.38</b>

Expense recognised in the statement of profit and loss

Particulars	For the Period ended September 30, 2018	For the year ended March 31, 2018	For the year ended March 31, 2017 Proforma Ind AS	For the year ended March 31, 2016 Proforma Ind AS
Current service cost	7.09	11.11	9.72	9.78
Net Interest (Income) / Expense	4.89	6.82	6.20	5.38
Past Service Cost	-	6.08	-	-
<b>Net periodic benefit cost recognised in the statement of profit and loss</b>	<b>11.98</b>	<b>24.01</b>	<b>15.92</b>	<b>15.16</b>

Amount recognised in Statement of Other Comprehensive Income (OCI)

Particulars	For the Period ended September 30, 2018	For the year ended March 31, 2018	For the year ended March 31, 2017 Proforma Ind AS	For the year ended March 31, 2016 Proforma Ind AS
Actuarial (Gains)/Losses on Obligation For the Year	16.51	8.94	11.17	5.43
Return on Plan Assets, Excluding Interest Income	0.61	0.13	(0.86)	0.39
<b>Net (Income)/Expense For the Year Recognized in OCI</b>	<b>17.12</b>	<b>9.07</b>	<b>10.31</b>	<b>5.82</b>



UNIPARTS INDIA LIMITED  
Annexure VI : Notes to Restated Consolidated Financial Information  
(All amounts in millions of INR, unless stated otherwise)

**Reconciliation of net asset/(liability) recognised:**

Particulars	As at September 30, 2018	As at March 31, 2018	As at March 31, 2017 Proforma Ind AS	As at March 31, 2016 Proforma Ind AS
Opening Net Liability	127.39	100.67	80.38	68.19
Expenses Recognized in Statement of Profit or Loss	11.98	24.01	15.92	15.16
Expenses Recognized in OCI	17.12	9.07	10.31	5.82
Net Liability/(Asset) Transfer In	-	0.03	0.10	-
Net (Liability)/Asset Transfer Out	-	(0.01)	(0.10)	-
(Benefit Paid Directly by the Employer) (Employer's Contribution)	(2.27)	(6.38)	(5.94)	(8.79)
<b>Net asset / (liability) recognised at the end of the year</b>	<b>154.21</b>	<b>127.39</b>	<b>100.67</b>	<b>80.38</b>

**The major categories of plan assets as a percentage of the fair value of total plan assets are as follows:**

Particulars	As at September 30, 2018	As at March 31, 2018	As at March 31, 2017 Proforma Ind AS	As at March 31, 2016 Proforma Ind AS
Insurance fund	17.96	17.88	16.87	14.87

**Other Details**

Particulars	As at September 30, 2018	As at March 31, 2018	As at March 31, 2017 Proforma Ind AS	As at March 31, 2016 Proforma Ind AS
No of Active Members	2,381	2,224	2,253	2,316
Per Month Salary For Active Members	38.22	32.94	31.42	29.70
Weighted Average Duration of the Projected Benefit Obligation for Gripwel Fasteners Private Limited	6.00	6.00	5.00	5.00
Weighted Average Duration of the Projected Benefit Obligation for Uniparts India Limited	7.00	7.00	6.00	6.00
Average Expected Future Service for Uniparts India Limited	7.00	7.00	5.00	5.00
Average Expected Future Service for Gripwel Fasteners Private Limited	6.00	6.00	5.00	5.00
<b>Projected Benefit Obligation (PBO)</b>	<b>154.21</b>	<b>127.39</b>	<b>100.67</b>	<b>80.38</b>
Prescribed Contribution For Next Year (12 Months)	32.08	28.52	27.25	25.54

**Maturity Analysis of Projected Benefit Obligation: From the Fund**

Particulars	As at September 30, 2018	As at March 31, 2018	As at March 31, 2017 Proforma Ind AS	As at March 31, 2016 Proforma Ind AS
Projected Benefits Payable in Future Years From the Date of Reporting				
1st Following Year	15.57	13.58	14.06	12.05
2nd Following Year	14.37	12.74	13.30	11.09
3rd Following Year	14.62	12.49	12.22	10.44
4th Following Year	16.20	12.75	11.05	9.47
5th Following Year	15.33	12.97	10.42	8.49
Sum of Years 6 To 10	63.40	52.30	37.14	30.94

**Maturity Analysis of Projected Benefit Obligation: From the Employer**

Particulars	As at September 30, 2018	As at March 31, 2018	As at March 31, 2017 Proforma Ind AS	As at March 31, 2016 Proforma Ind AS
Projected Benefits Payable in Future Years From the Date of Reporting				
1st Following Year	7.48	5.16	4.28	4.36
2nd Following Year	4.00	4.90	3.84	3.22
3rd Following Year	3.96	3.60	5.01	2.87
4th Following Year	4.79	3.93	3.24	3.85
5th Following Year	3.37	3.06	3.17	2.37
Sum of Years 6 To 10	15.02	12.32	9.21	7.88

**Sensitivity analysis**

**A) Impact of change in discount rate when base assumption is decreased/increased present value of obligation**

Discount Rate	As at September 30, 2018	As at March 31, 2018	As at March 31, 2017 Proforma Ind AS	As at March 31, 2016 Proforma Ind AS
Decrease by 1%	10.11	8.28	5.26	4.00
Increase by 1%	(9.05)	(7.43)	(4.79)	(3.65)

**B) Impact of change in salary increase rate when base assumption is decreased/increased present value of obligation**

Salary increment rate	As at September 30, 2018	As at March 31, 2018	As at March 31, 2017 Proforma Ind AS	As at March 31, 2016 Proforma Ind AS
Decrease by 1%	(8.62)	(7.25)	(4.62)	(3.81)
Increase by 1%	9.36	7.86	4.96	4.10

UNIPARTS INDIA LIMITED

Annexure VI : Notes to Restated Consolidated Financial Information

(All amounts in millions of INR, unless stated otherwise)

**C) Impact of change in withdrawal rate when base assumption is decreased/increased present value of obligation**

Withdrawal rate	As at September 30, 2018	As at March 31, 2018	As at March 31, 2017 Proforma Ind AS	As at March 31, 2016 Proforma Ind AS
Decrease by 1%	0.45	(0.23)	(0.47)	(0.71)
Increase by 1%	(0.42)	0.20	0.42	0.63

Sensitivity analysis is an analysis which will give the movement in liability if the assumptions were not proved to be true on different count. This only signifies the change in the liability if the difference between assumed and the actual is not following the parameters of the sensitivity analysis. Since investment is with insurance company, Assets are considered to be secured.

**The following are the expected Interest cost for Next year:**

Particulars	For the Period ended September 30, 2018	For the year ended March 31, 2018	For the year ended March 31, 2017 Proforma Ind AS	For the year ended March 31, 2016 Proforma Ind AS
Present Value of Benefit Obligation at the End of the year (Fair Value of Plan Assets at the End of the year)	172.17 17.78	145.26 (17.88)	117.56 (16.87)	95.24 (14.87)
Net Liability/(Asset) at the End of the year	189.95	127.38	100.69	80.38
Interest Cost (Interest Income)	14.26 (1.49)	11.15 (1.37)	7.96 (1.14)	22.34 (1.15)
<b>Net Interest Cost for Next Year</b>	<b>12.77</b>	<b>9.78</b>	<b>6.82</b>	<b>21.19</b>

**The following are the expected expenses to be recognised in the Statement of Profit or Loss for Next Year:**

Particulars	For the Period ended September 30, 2018	For the year ended March 31, 2018	For the year ended March 31, 2017 Proforma Ind AS	For the year ended March 31, 2016 Proforma Ind AS
Current Service Cost	16.40	14.18	11.11	9.72
Net Interest Cost (Expected Contributions by the Employees)	12.77 -	9.77 -	6.82 -	6.20 -
<b>Expenses Recognized</b>	<b>29.17</b>	<b>23.95</b>	<b>17.93</b>	<b>15.92</b>

**(b) Leave Encashment**

The leave obligations cover the Company's liability for sick and earned leaves. The Company does not have an unconditional right to defer settlement for the obligation shown as current provision balance above. However based on past experience, the Company does not expect all employees to take the full amount of accrued leave or require payment within the next 12 months, therefore based on the independent actuarial report, only a certain amount of provision has been presented as current and remaining as non-current. Amount for the period ended September 30, 2018 is INR 5.30 million (for the year ended March 31, 2018, 2017 and 2016 at INR 13.71 million, INR 8.52 million, INR 8.02 million) has been recognised in the statement of profit and loss.

Particulars	As at September 30, 2018		As at 31st March, 2018		As at 31st March, 2017 Proforma Ind AS		As at March 31, 2016 Proforma Ind AS	
	Current	Non-current	Current	Non-current	Current	Non-current	Current	Non-Current
Compensated absences	18.90	22.92	21.65	19.27	19.84	14.16	15.71	11.17

**UNIPARTS INDIA LIMITED**  
**Annexure VI : Notes to Restated Consolidated Financial Information**  
**(All amounts in millions of INR, unless stated otherwise)**

**34A. Share Based Payments**

**(a) Scheme Details**

The Company's ESOP scheme "Uniparts Employees Stock Option Plan, 2007" is administered through an ESOP Trust, which subscribes to shares of the Company and holds them until issuance thereof based on vesting and exercise of options by employees. The scheme provides that subject to continued employment with the Company, specified employees of the Company and its subsidiaries are granted an option to acquire equity shares of the Company that may be exercised within a specified period. Each option comprises of one equity share which will vest on annual basis in equal proportion over a period of three years (except Grant-11 which shall vest 100% on the expiry of 12 months from the grant date) and shall be capable of being exercised within a period of fifteen years from the date of the specified grant. Each option granted under the above plan entitles the holder to one equity share of the Company at an exercise price, which is approved by the Nomination and Remuneration Committee. The Company has provided an interest free loan amounting to INR 55.20 million to the Trust to subscribe to 350400 Shares issued at INR 135 per share and right issue of 175200 Shares at INR 45 per share. The ESOP Trust has since subscribed to the Company's shares. As per IND AS 102 "Share-based Payment" and the Guidance Note on Accounting for Employee Share Based payments issued by the Institute of Chartered Accountants of India, the amount of loan equivalent to the face value of securities subscribed INR 5.13 million has been deducted from share capital account and the balance part of the loan representing the amount of share premium paid for the shares subscribed INR 50.06 million has been deducted from the share premium account. The balance of such loan as at September 30, 2018 is INR 53.39 million. The repayment of loan is primarily dependent upon the exercise of options by the employees, the price at which fresh or reissued options are granted and dividend income earned thereon till exercise of options. The Company believes that the options would be exercised by the employees and the ESOP Trust would be able to repay the loan based on the price received by the Trust there against. On that basis, the loan to the ESOP Trust is considered good of recovery.

As per the Scheme, the Company has granted 1,14,833 options @ INR 135/- per option (Grant – 1), 42,764 options @ INR 135/- per option (Grant – 2), 25,000 options @ INR 135/- per option (Grant – 3), 86,592 Right Issue @ INR 45/- per share, 28,912 options @ INR 105/- per option (Grant – 4), 26,209 options @ INR 105/- per option (Grant – 5), 28,825 options @ INR 105/- per option (Grant – 6), 11,255 options @ INR 105/- per option (Grant – 7), 5,000 options @ INR 105/- per option (Grant – 8), 21,465 options @ INR 105/- per option (Grant – 9), 324,637 Bonus Issue @ Nil per share, 35,102 options @ INR 52.50 per option (Grant – 10) and 52,948 options @ INR 52.50 per option (Grant – 11) in accordance with the provisions of the Securities and Exchange Board of India (Share Based Employee Benefits) Regulations, 2014, to the selected employees of the Company. The method of settlement is by issue of equity shares to the selected employees who have accepted the option.

Period within which options will vest to the participants

Grant-1 to Grant-10

2 years from the date of Grant of Options 33%

3 years from the date of Grant of Options 33%

4 years from the date of Grant of Options 34%

Grant-11

12 months from the date of Grant of Options 100%

**(b) Share Based Payment activity under Scheme 2007 is as follows:**

Particulars	For the Period ended September 30, 2018	For the year ended March 31, 2018	For the year ended March 31, 2017 Proforma Ind	For the year ended March 31, 2016
			AS	Proforma Ind AS
Outstanding at the beginning of the year	643,988	643,988	684,376	684,376
Bonus Issue during the year	-	-	-	-
Granted during the year	-	-	-	52,948
Forfeited/Surrendered during the year	-	-	40,388	52,948
Exercised during the year	-	-	-	-
Outstanding at the end of the year	643,988	643,988	643,988	684,376
Vested and Exercisable at the end of the year	612,858	612,858	612,858	510,132

**UNIPARTS INDIA LIMITED****Annexure VI : Notes to Restated Consolidated Financial Information**

(All amounts in millions of INR, unless stated otherwise)

**(c) Weighted average fair value of Options on the date of Grant**

<b>Particulars</b>	<b>(Amount in INR)</b>
	<b>As at September 30, 2018</b>
Grant 1	96.45
Grant 2	114.02
Grant 3	70.45
Right Issue	97.65
Grant 4	56.69
Grant 5	77.63
Grant 6	67.19
Grant 7	41.10
Grant 8	47.08
Grant 9	55.00
Grant 10	32.50
Grant 11	38.26

The Company follows the Fair Market Value calculated on Black Scholes Method to account for compensation expenses arising from issuance of stock options to the employees.

**(d) Inputs in the model**

<b>Option series</b>	<b>(Amount in INR)</b>
	<b>Grant-11</b>
<b>Particulars</b>	
Grant date share price	43.60
Exercise price	52.50
Expected volatility	14.90%
Option Life	8
Dividend yield	1.34%
Risk-free interest rate	8.12%

**UNIPARTS INDIA LIMITED**
**Annexure VI : Notes to Restated Consolidated Financial Information**

(All amounts in millions of INR, unless stated otherwise)

**(e) Share options outstanding at the end of the year**

Option Details		Options Outstanding				Remaining contractual life				Exercise price
		As at 30 September, 2018	As at 31 March, 2018	As at 31 March, 2017 Proforma Ind AS	As at 31 March, 2016 Proforma Ind AS	As at 30 September, 2018	As at 31 March, 2018	As at 31 March, 2017 Proforma Ind AS	As at 31 March, 2016 Proforma Ind AS	
Grant-1	08/02/2007	89,754	89,754	89,754	89,754	-	-	-	-	135.00
Grant-2	27/03/2008	20,357	20,357	20,357	24,691	-	-	-	-	135.00
Grant-3	27/03/2009	25,000	25,000	25,000	25,000	-	-	-	-	135.00
Right Issue	Right Issue	67,556	67,556	67,556	69,723	-	-	-	-	45.00
Grant-4	25/03/2011	22,785	22,785	22,785	26,545	-	-	-	-	105.00
Grant-5	03/03/2012	11,268	11,268	11,268	14,911	-	-	-	-	105.00
Grant-6	12/01/2013	22,535	22,535	22,535	28,825	-	-	-	0.27	105.00
Grant-7	25/09/2013	-	-	-	-	-	-	-	0.99	105.00
Grant-8	23/12/2013	5,000	5,000	5,000	5,000	-	-	0.25	1.16	105.00
Grant-9	15/02/2014	21,465	21,465	21,465	21,465	-	-	0.33	1.26	105.00
Bonus Issue	Bonus issue	285,720	285,720	285,720	305,914	-	-	-	-	-
Grant-10	23/08/2014	19,600	19,600	19,600	19,600	-	0.13	0.94	2.39	52.50
Grant-11	30/06/2015	52,948	52,948	52,948	52,948	-	-	2.25	1.24	52.50
		<b>643,988</b>	<b>643,988</b>	<b>643,988</b>	<b>684,376</b>					

**(f) Compensation expenses arising on account of the share based payments**

	As at September 30, 2018	As at March 31, 2018	As at March 31, 2017 Proforma Ind AS	As at March 31, 2016 Proforma Ind AS
Expenses arising from equity – settled share-based payment transactions	0.02	0.29	0.77	1.49

**UNIPARTS INDIA LIMITED**
**Annexure VI : Notes to Restated Consolidated Financial Information**

(All amounts in millions of INR, unless stated otherwise)

**35. Details of dues to micro and small enterprises as defined under micro, small and medium enterprises development act, 2006 (MSMED, Act 2006)**
**Dues to micro enterprises and small enterprises**

The Ministry of Corporate Affairs has issued notification no.G.S.R 1022(E) dated October 11, 2018 which prescribes certain disclosures regarding amount payable to micro enterprises and small enterprises. Accordingly, the disclosure in respect of the amounts payable to such enterprises as at September 30, 2018 INR 6.25 million (March 31, 2018: Nil, March 31, 2017: Nil, March 31, 2016: Nil) has been made in the financial statements based on information received and available with the Company. Further in view of the Management, the impact of interest, if any, that may be payable in accordance with the provisions of the Act is not expected to be material. The Company has not received any claim for interest from any supplier as at the balance sheet date.

Particulars	For the period ended September 30, 2018	For the Year ended March 31,2018	For the Year ended March 31,2017 Proforma Ind AS	For the Year ended March 31,2016 Proforma Ind AS
The principal amount and the interest due thereon remaining unpaid to any supplier as at the end of each accounting year;				
– Principal	6.25	-	-	-
– Interest	-	-	-	-
The amount of interest paid by the buyer in terms of Section 16 of the Micro, Small and Medium Enterprises Development Act, 2006, (the Act) along with the amount of the payment made to the supplier beyond the appointed day during each accounting year	-	-	-	-
The amount of interest due and payable for the period of delay in making payment (which have been paid but beyond the appointed day during the year) but without adding the interest specified under the said Act	-	-	-	-
The amount of interest accrued and remaining unpaid at the end of each year	-	-	-	-
The amount of further interest remaining due and payable even in the succeeding years, until such date when the interest dues as above are actually paid to the small enterprise.	-	-	-	-

**36. Related party disclosure**

(i) List of the related parties where control exists and related parties with whom transactions have taken place and relationships:

**A) Related parties where control exists**
**a) Subsidiaries**

Name of the Company	Country of Incorporation	% of voting power held as at September 30, 2018	% of voting power held as at March 31, 2018	% of voting power held as at March 31, 2017 Proforma Ind AS	% of voting power held as at March 31, 2016 Proforma Ind AS
Uniparts USA Limited	USA	100	100	100	100
Uniparts Europe BV	Netherlands	100	100	100	100
Gripwel Fasteners Private Limited	India	100	100	100	100
Uniparts India GmbH	Germany	100	100	100	100

**b) Step down Subsidiaries**

Name of the Company	Country of Incorporation	% of voting power held as at September 30, 2018	% of voting power held as at March 31, 2018	% of voting power held as at March 31, 2017 Proforma Ind AS	% of voting power held as at March 31, 2016 Proforma Ind AS
Uniparts Olsen Inc.	USA	100	100	100	100

**UNIPARTS INDIA LIMITED****Annexure VI : Notes to Restated Consolidated Financial Information****(All amounts in millions of INR, unless stated otherwise)****B) Enterprises over which Key Managerial Personnel and their relatives exercise significant influence:**

SKG Engineering Pvt. Ltd.  
Sweaty Spirit Apparel Limited (Formerly known as Ace Tractor Parts Ltd.)  
Avid Maintenance LLP (Formerly known as Avid Maintenance Pvt. Ltd.)  
SGA Trading Pvt. Ltd.  
Tima Trading Pvt. Ltd.  
Amazing Estates Pvt. Ltd.  
Vivify Net Pvt. Ltd.  
GKP Farms Pvt. Ltd.  
Silveroak Estates Pvt. Ltd.  
Uniparts Engineering Pvt. Ltd.  
Charisma Homes LLP (Formerly known as Charisma Homes Pvt. Ltd.)  
Bluebells Homes Pvt. Ltd.(Formerly known as Oilintec Pvt. Ltd. )  
Gripwel Fasteners (Partnership Firm)  
Farmparts Company (Partnership Firm)  
Soni Holdings (Partnership Firm)  
P Soni Family Trust  
Sepoy Beverages LLP (w.e.f. October 27, 2017)  
Ninety Hospitality LLP (w.e.f. April 17, 2017)  
Soni Foundation  
Indento International (Partnership Firm)  
Kirpal Singh (HUF)  
Paramjit Singh (HUF)  
Gurdeep Soni (HUF)  
Beekay Travels Pvt. Ltd.  
Paper Bag Entertainment Inc.  
Diamante (Partnership Firm)  
Leon India (Partnership Firm) (w.e.f. July 28, 2017)

**C) Key Managerial Personnel / Individuals having significant influence on the Company:**

Gurdeep Soni-Chairman & Managing Director  
Paramjit Singh Soni- Vice Chairman & Director  
Herbert Klaus Coenen-Director  
Madhukar Rangnath Umarji - Independent Director  
Sharat Krishan Mathur - Independent Director  
Alok Nagory - Independent Director  
Shardha Suri - Independent Director  
Parmeet Singh Kalra - Independent Director  
Sanjiv Kashyap - Chief Financial Officer  
Sudhakar Simhachala Kolli - Group Chief Operating Officer (w.e.f. February 08, 2016)  
Lalit Khanna - Company Secretary (upto February 4, 2016)  
Mukesh Kumar - Company Secretary (w.e.f. February 5, 2016)  
Rini Kalra - Head M&A / Funding

**D) Relatives of Key Managerial Personnel \***

Angad Soni (Son of Gurdeep Soni)  
Pamela Soni (Wife of Gurdeep Soni)  
Karan Soni (Son of Paramjit Singh Soni)  
Meher Soni (Daughter of Paramjit Singh Soni)  
Arjun Soni (Son of Gurdeep Soni)

*\*Relatives of Key Managerial Personnel with whom transactions have taken place during the respective period / year*

**UNIPARTS INDIA LIMITED**

**Annexure VI : Notes to Restated Consolidated Financial Information**

(All amounts in millions of INR, unless stated otherwise)

(ii) The Key Managerial Personnel, their Relatives and Associates have given certain personal guarantees and collaterals for the loans/other credit facilities taken by the Company from various banks/financial institutions:

**Uniparts India Limited**

S.No.	Name of Bank	Amount Guaranteed				Personal Guarantee	Collateral Security
		As at September 30, 2018	As at March 31, 2018	As at March 31, 2017 Proforma Ind AS	As at March 31, 2016 Proforma Ind AS		
1	Citibank NA	700.00	600.00	407.50	407.50	Gurdeep Soni (KMP) & Paramjit Singh Soni (KMP)	Lien on investment in the units of Kotak Alternate Opportunities (India) Fund in the name of Mr. Gurdeep Soni (KMP) and Mr. Paramjit Singh Soni (KMP).
2	Kotak Mahindra Bank Limited	550.00	550.00	558.60	550.00	Gurdeep Soni (KMP) & Paramjit Singh Soni (KMP)	Pledge on Mutual fund units belongings to Mrs. Pamela Soni (Relative of KMP) & Gurdeep Soni (KMP) against the FCTL Facility of Rs 8.60 Million up to March 31, 2017 and Mortgage by way of first pari-passu charge on the Apartment # K-0401, 4th Floor, Tower K, Phase IV, Central Park-1, Gurgaon owned by the Mr. Gurdeep Soni (KMP) and Mrs. Pamela Soni (Relative of KMP)
3	IndusInd Bank	168.80	425.00	425.00	375.00	Gurdeep Soni (KMP) & Paramjit Singh Soni (KMP)	Exclusive charge on the Apartment # K-0401, 4th Floor, Tower K, Phase IV, Central Park-1, Gurgaon, owned by the Mr. Gurdeep Soni (KMP) and Mrs. Pamela Soni (Relative of KMP)
4	DBS Bank	400.00	300.00	300.00	300.00	Gurdeep Soni (KMP) & Paramjit Singh Soni (KMP)	-



UNIPARTS INDIA LIMITED  
Annexure VI : Notes to Restated Consolidated Financial Information  
(All amounts in millions of INR, unless stated otherwise)

(iii) Outstanding Balances

Particulars	As at September 30, 2018	As at March 31, 2018	As at March 31, 2017 Proforma Ind AS	As at March 31, 2016 Proforma Ind AS
<b>1. Uniparts ESOP Trust</b>				
-In Loan Account	53.39	53.39	53.39	53.39
<b>2. SKG Engineering Pvt. Ltd</b>				
-In Trade Account			-	40.25
<b>3. Farmparts Company</b>				
-In Trade Account	-	-	1.25	1.25

Disclosure in respect of Related Party Transactions during the period / year:

Particulars	Relationship	For the period ended September 30, 2018	For the Year ended March 31, 2018	For the Year March 31, 2017 Proforma Ind AS	For the Year March 31, 2016 Proforma Ind AS
<b>1 Purchase of Tangible Asset</b>					
SKG Engineering Pvt. Ltd.	Enterprises over which Key Managerial Personnel and their relatives exercise significant influence	-	-	-	67.02
		-	-	-	<b>67.02</b>
<b>2 Rent Paid</b>					
SKG Engineering Pvt.Ltd	Enterprises over which Key Managerial Personnel and their relatives exercise significant influence	-	-	-	3.79
Soni Holdings	Enterprises over which Key Managerial Personnel and their relatives exercise significant influence	0.94	1.83	1.58	1.48
		<b>0.94</b>	<b>1.83</b>	<b>1.58</b>	<b>5.27</b>
<b>3 Current Account Payments</b>					
Gurdeep Soni-Current Account	Key Managerial Personnel	-	-	-	0.08
Kirpal Singh Soni-Current Account	Relative of Key Managerial Personnel	-	-	-	-
		-	-	-	<b>0.08</b>
<b>4 Dividend Paid</b>					
Angad Soni	Relative of Key Managerial Personnel	0.05	-	-	0.04
Gurdeep Soni	Key Managerial Personnel	14.96	-	-	11.22
Pamela Soni	Relative of Key Managerial Personnel	1.98	-	-	1.48
Arjun Soni	Relative of Key Managerial Personnel	0.01	-	-	0.01
Paramjit Singh Soni	Key Managerial Personnel	6.60	-	-	4.95
Meher Soni	Relative of Key Managerial Personnel	5.20	-	-	3.90
Karan Soni	Relative of Key Managerial Personnel	5.20	-	-	3.90
		<b>34.00</b>	-	-	<b>25.50</b>
<b>5 Sitting Fees</b>					
Alok Nagory	Independent Director	0.10	-	0.15	0.10
Madhukar Rangnath Umarji	Independent Director	0.16	0.32	0.32	0.25
Sharat Krishan Mathur	Independent Director	0.22	0.37	0.44	0.44
Shradha Suri	Independent Director	0.10	0.05	0.15	0.10
Parmeet Singh Kalra	Independent Director	-	0.06	0.04	0.10
		<b>0.58</b>	<b>0.80</b>	<b>1.10</b>	<b>0.99</b>
<b>6 Salary and Allowances</b>					
Angad Soni	Relative of Key Managerial Personnel	1.14	2.36	2.36	2.32
		<b>1.14</b>	<b>2.36</b>	<b>2.36</b>	<b>2.32</b>
<b>7 Commission</b>					
Madhukar Rangnath Umarji	Independent Director	-	1.10	-	-
		-	<b>1.10</b>	-	-
<b>8 Key Managerial Person Remuneration*</b>					
Sanjiv Kashyap	Chief Financial Officer	5.78	9.48	9.96	9.85
Sudhakar Simhachala Kolli	Group Chief Operating Officer	10.37	15.53	13.26	1.47
Mukesh Kumar	Company Secretary	2.97	4.69	3.93	0.80
Lalit Khanna	Company Secretary	-	-	-	5.87
Rini Kalra	Head M&A / Funding	6.14	13.71	13.95	13.60
Gurdeep Soni	Managing Director	8.40	16.80	17.50	17.70
Paramjit Singh Soni	Director	18.00	33.84	36.44	41.59
Herbert Klaus Coenen	Director	8.47	19.55	14.35	15.21
		<b>60.13</b>	<b>113.60</b>	<b>109.39</b>	<b>106.08</b>
<b>9 ESOP granted to Key Managerial Person</b>					
Rini Kalra	Head M&A / Funding	-	-	-	2.78
		-	-	-	<b>2.78</b>

\* Excludes contribution to employee retirement/post retirement and other employee benefits which are based on actuarial valuation done on an overall Company basis

UNIPARTS INDIA LIMITED  
Annexure VI : Notes to Restated Consolidated Financial Information  
(All amounts in millions of INR, unless stated otherwise)

(iv) Transactions and outstanding balances with subsidiaries, eliminated during the consolidation for Uniparts India Limited:

a. Outstanding Balances

Particulars	As at September 30, 2018	As at March 31, 2018	As at March 31, 2017 Proforma Ind AS	As at March 31, 2016 Proforma Ind AS
<b>1. Gripwel Fasteners Pvt. Ltd.</b>				
-In Trade Account	72.72	67.24	111.77	108.76
-In Equity Shares	49.87	49.87	49.87	49.87
<b>2. Uniparts USA Limited</b>				
-In Trade Account	92.28	118.58	66.76	80.12
-In Common Stock	0.87	0.87	0.87	0.87
-In Preferred Stock	392.67	392.67	392.67	392.67
<b>3. Uniparts Europe B.V.</b>				
-In Equity Shares	71.06	71.06	71.06	71.06
<b>4. Uniparts India GmbH</b>				
-In Trade Account	137.62	136.60	122.75	143.81
-In Equity Shares	5.94	5.94	5.94	5.94
<b>5. Uniparts Olsen Inc.</b>				
-In Trade Account	62.87	35.04	55.41	78.64

b. Transactions during the respective period/year:

Particulars	Relationship	For the period ended September 30, 2018	For the year ended March 31, 2018	For the year ended March 31, 2017 Proforma Ind AS	For the year ended March 31, 2016 Proforma Ind AS
<b>1 Purchase of Goods/Samples</b>					
Gripwel Fasteners Pvt. Ltd.	Subsidiary	7.08	21.66	10.06	16.89
Uniparts India GmbH	Subsidiary	10.13	23.96	18.13	39.48
		<b>17.21</b>	<b>45.62</b>	<b>28.19</b>	<b>56.37</b>
<b>2 Sale of Goods</b>					
Gripwel Fasteners Pvt. Ltd.	Subsidiary	390.95	663.99	471.47	492.37
Uniparts India GmbH	Subsidiary	234.77	415.12	288.64	372.54
Uniparts Olsen Inc.	Step-Down Subsidiary	501.83	726.44	605.33	569.05
Uniparts USA Limited	Subsidiary	473.73	759.60	430.64	670.26
		<b>1,601.28</b>	<b>2,565.15</b>	<b>1,796.08</b>	<b>2,104.22</b>
<b>3 Purchase of Tangible Asset</b>					
Gripwel Fasteners Pvt. Ltd.	Subsidiary	-	-	-	0.04
		-	-	-	<b>0.04</b>
<b>4 Job Work income</b>					
Gripwel Fasteners Pvt. Ltd.	Subsidiary	0.57	1.28	0.90	1.43
		<b>0.57</b>	<b>1.28</b>	<b>0.90</b>	<b>1.43</b>
<b>5 Dividend Income</b>					
Gripwel Fasteners Pvt. Ltd.	Subsidiary	37.44	-	-	23.04
		<b>37.44</b>	-	-	<b>23.04</b>
<b>6 Lease Rent on Machine Received</b>					
Gripwel Fasteners Pvt. Ltd.	Subsidiary	3.57	7.14	7.14	7.15
		<b>3.57</b>	<b>7.14</b>	<b>7.14</b>	<b>7.15</b>
<b>7 Current Account Receipts</b>					
Gripwel Fasteners Pvt. Ltd.	Subsidiary	-	5.89	9.29	11.74
		-	<b>5.89</b>	<b>9.29</b>	<b>11.74</b>
<b>8 Current Account Payments</b>					
Gripwel Fasteners Pvt. Ltd.	Subsidiary	-	5.89	9.29	11.74
		-	<b>5.89</b>	<b>9.29</b>	<b>11.74</b>
<b>9 Reimbursement of Expenses</b>					
Gripwel Fasteners Pvt. Ltd.	Subsidiary	-	-	-	0.35
Uniparts USA Limited	Subsidiary	-	-	0.10	0.58
Uniparts India GmbH	Subsidiary	-	-	0.50	-
		-	-	<b>0.60</b>	<b>0.93</b>
<b>10 Recovery of Expenses</b>					
Gripwel Fasteners Pvt. Ltd.	Subsidiary	-	-	-	0.10
Uniparts India GmbH	Subsidiary	-	8.86	-	-
Uniparts USA Limited	Subsidiary	-	-	-	3.92
		-	<b>8.86</b>	-	<b>4.02</b>
<b>11 Other Income</b>					
Uniparts Olsen Inc.	Step-Down Subsidiary	0.06	0.20	9.79	0.31
Uniparts USA Limited	Subsidiary	-	0.45	0.42	2.23
Uniparts India GmbH	Subsidiary	1.51	0.51	1.26	1.12
		<b>1.57</b>	<b>1.16</b>	<b>11.47</b>	<b>3.66</b>
<b>12 Guarantees and Collaterals Given</b>					
Gripwel Fasteners Pvt. Ltd.	Subsidiary	225.00	175.00	175.00	175.00
		<b>225.00</b>	<b>175.00</b>	<b>175.00</b>	<b>175.00</b>

**UNIPARTS INDIA LIMITED**  
**Annexure VI : Notes to Restated Consolidated Financial Information**  
**(All amounts in millions of INR, unless stated otherwise)**

**(v) Transactions and outstanding balances entered by Gripwel Fasteners Private Limited with fellow subsidiaries, eliminated during the consolidation:**

**a. Outstanding Balances**

Particulars	As at September 30, 2018	As at March 31, 2018	As at March 31, 2017 Proforma Ind AS	As at March 31, 2016 Proforma Ind AS
Uniparts USA Limited	121.17	70.34	22.54	34.93
Uniparts India GmbH	105.51	64.40	36.18	30.30
Uniparts Olsen Inc.	37.30	24.27	18.48	16.99

**b. Transactions during the respective period / year:**

Particulars	Relationship	For the period ended September 30, 2018	For the year ended March 31, 2018	For the year ended March 31, 2017 Proforma Ind AS	For the year ended March 31, 2016 Proforma Ind AS
<b>1 Purchase of Goods/Samples/Packing and Services</b>					
Uniparts India GmbH	Fellow Subsidiary	2.18	5.13	4.29	5.83
		<b>2.18</b>	<b>5.13</b>	<b>4.29</b>	<b>5.83</b>
<b>2 Sale of Goods</b>					
Uniparts India GmbH	Fellow Subsidiary	93.97	153.33	98.27	85.82
Uniparts USA Limited	Fellow Subsidiary	141.66	199.55	76.69	90.44
Uniparts Olsen Inc.	Fellow Subsidiary	171.37	261.19	137.27	178.86
		<b>407.00</b>	<b>614.08</b>	<b>312.23</b>	<b>355.12</b>
<b>3 Lease Rentals</b>					
Soni Holdings	Enterprises over which Key Managerial Personnel and their relatives exercise significant influence	0.47	0.93	0.84	0.79
		<b>0.47</b>	<b>0.93</b>	<b>0.84</b>	<b>0.79</b>

**(vi) Transactions and outstanding balances entered by Uniparts Europe BV with fellow subsidiary other than the transactions reported in other sections, eliminated during the consolidation:**

**a. Outstanding Balances**

Particulars	As at September 30, 2018	As at March 31, 2018	As at March 31, 2017 Proforma Ind AS	As at March 31, 2016 Proforma Ind AS
Uniparts India GmbH				
-In Loan and Advance Account	50.51	48.14	41.46	45.24
	<b>50.51</b>	<b>48.14</b>	<b>41.46</b>	<b>45.24</b>

**b. Transactions during the respective period / year:**

Particulars	Relationship	For the period ended September 30, 2018	For the year ended March 31, 2018	For the year ended March 31, 2017 Proforma Ind AS	For the year ended March 31, 2016 Proforma Ind AS
<b>1 Interest Income</b>					
Uniparts India GmbH	Fellow Subsidiary	0.57	1.06	1.03	1.01
		<b>0.57</b>	<b>1.06</b>	<b>1.03</b>	<b>1.01</b>

**(vii) Funding arrangements including inter-se guarantees among the entities consolidated excluding contribution to equity share capital:**

**Guarantees and Collaterals Given**

Executed by	On behalf of	For the period ended September 30, 2018	For the year ended March 31, 2018	For the year ended March 31, 2017 Proforma Ind AS	For the year ended March 31, 2016 Proforma Ind AS
Uniparts India Limited	Gripwel Fasteners Pvt. Ltd.	225.00	175.00	175.00	175.00
Uniparts USA Limited	Uniparts Olsen Inc.	616.34	996.18	992.36	1,013.78
Uniparts Olsen Inc.	Uniparts USA Limited	622.14	330.76	329.49	336.60

There is no important terms and conditions and fund transfer restrictions on the above Funding arrangements

**Loans**

Lender	Borrower	For the period ended September 30, 2018	For the year ended March 31, 2018	For the year ended March 31, 2017 Proforma Ind AS	For the year ended March 31, 2016 Proforma Ind AS
Uniparts Europe BV	Uniparts India GmbH	50.51	48.14	41.46	45.24

Interest will be paid on EURIBOR + 230 bps, there is no other important terms and conditions and fund transfer restrictions on the above Funding arrangement.

**UNIPARTS INDIA LIMITED**  
**Annexure VI : Notes to Restated Consolidated Financial Information**  
(All amounts in millions of INR, unless stated otherwise)

**37. Capital and other commitments**

Particulars	As at September 30, 2018	As at March 31, 2018	As at March 31, 2017 Proforma Ind AS	As at March 31, 2016 Proforma Ind AS
<b>(i) Claims against the company not acknowledged as debt:</b>				
-Sales Tax Matters	2.34	1.49	1.10	0.42
-Service Tax Matters	0.23	0.23	0.25	0.23
-Custom Matters	1.60	1.60	-	-
-Excise Matters	0.94	0.94	0.92	1.10
-Labour Matters	Not Ascertainable	Not Ascertainable	Not Ascertainable	Not Ascertainable
<b>(ii) Sales Tax Liability against Pending Forms</b>	0.74	0.96	55.31	51.67
<b>(iii) Income Tax Demands</b>	0.36	23.13	23.13	4.06
<b>(iv) Others</b>	-	-	-	-
Guarantees given on behalf of the company by the Banks:				
-Sales Tax Matters	0.03	0.03	0.03	0.03
-Pollution Control Board	0.02	0.02	0.02	0.02
-Excise Matters	0.50	0.50	0.50	0.50
- Custom Matters	-	0.18	-	-
- Gas Connections	2.68	2.68	-	-
<b>(v) Estimated amount of contracts remaining to be executed on Capital Accounts and not provided for (Net of Advances)</b>	120.24	119.41	94.88	21.94
<b>(vi) Other money for which the company is contingently liable:</b>				
Guarantees given on behalf of the company by others:				
SBLC (Stand By Letter of Credit) for Wholly Owned Subsidiaries	9.25	8.30	8.27	8.45
<b>(vii) Excise Duty outstanding against exports made under Bond:</b>	-	-	0.53	0.41
<b>(viii) Excise Duty outstanding against exports made under Declaration/Undertaking</b>	-	-	14.09	14.09
<b>(ix) Bond cum Legal Undertaking to Andhra Pradesh Special Economic Zone and Noida Special Economic Zone</b>	1,699.73	1,699.73	1,699.73	1,757.53
<b>(x) Quality claims pending to customer by step-down subsidiary</b>	-	-	-	-

**38. Government Grant**

**Grant for purchase of Plant and Machinery**

Uniparts India Limited has availed tax and duty benefit in the nature of exemption from payment of Customs Duty, on its procurements with respect to Plant and Machinery. The said benefits were availed which entitled Uniparts India Limited to procure goods without payment of taxes and duties of amount for INR 4.36 million under Zero Duty EPCG Scheme.

In accordance with Ind AS 20 "Accounting for Government Grants and Disclosure of Government Assistance" Uniparts India Limited has grossed up the value of property, plant and equipment by the amount of tax and duty benefit availed considering the same as government grant. The amount of said government grant has been added to the value of CWIP property, plant and equipment with corresponding credit to deferred government grant, the amount of grant shall be amortized on a systematic basis in line with depreciation to be charged on property, plant and equipment.

Deferred government grant is disclosed in the financial statements as follows :

Particulars	For the period ended September 30, 2018	For the Year ended March 31, 2018	For the Year ended March 31, 2017 Proforma Ind AS	For the Year ended March 31, 2016 Proforma Ind AS
Opening Balance	4.36	-	-	-
Grant recognized during the year	94.28	160.77 *	122.17	131.00
Less : Amount recognized in statement of profit and loss**	94.28	156.41	122.17	131.00
<b>Closing Balance</b>	<b>4.36</b>	<b>4.36</b>	-	-
Disclosed under other non-current liability	4.14	4.29	-	-
Disclosed under other current liability	0.22	0.07	-	-

\* Includes Government Grant against procurement of capital goods of INR 4.36 million

\*\* There is no unfulfilled condition or contingencies attached to these grants.

## **UNIPARTS INDIA LIMITED**

### **Annexure VI : Notes to Restated Consolidated Financial Information**

**(All amounts in millions of INR, unless stated otherwise)**

#### **39. First time adoption**

The Group's financial statements for the period ended September 30, 2018, are the first financial statements that has been prepared in accordance with Ind AS together with the comparative period data as at and for the year ended March 31, 2018, as described in the summary of significant accounting policies. The transition to IND AS has been carried out in accordance with Ind AS 101 - First time adoption of Indian Accounting Standards, with April 1, 2017 as the transition date.

The restated financial statement for the year ended March 31, 2017 and March 31, 2016 has been prepared on Proforma basis (i.e. "Proforma Ind AS") The company has followed the same accounting policies and accounting policy choices (both mandatory exceptions and optional exemptions availed as per Ind AS - 101 ) as initially adopted on transition date by way of suitable restatement adjustments (both re-measurement and reclassification in the Proforma Ind AS financial information for the year ended March 31, 2017 and March 31, 2016.

Effective April 1, 2018, the Company adopted Ind AS 115 'Revenue from Contracts with Customers'. The standard is applied retrospectively with the cumulative effect of initially applying this standard as an adjustment to the opening balance of retained earnings at the date of initial application. The adoption of this Ind AS 115 did not have any impact on the overall revenue and/or opening balance of retained earnings.

#### **39A. Exemption in accordance with Ind-AS 101 (First Time Adoption of Indian Accounting Standards)**

In preparing these Restated Financial Information, the Company has availed itself of certain exemptions and exceptions in accordance with Ind AS 101 as explained below:

##### **a) Property, plant and equipment and Intangibles**

As permitted by Ind AS 101, the Company has elected to continue with the carrying values under previous GAAP as 'deemed cost' at April 1, 2016 for all the items of property, plant & equipment. For the purpose of Restated Financial Information for the financial years ended March 31, 2018, 2017 and 2016 the Company has provided depreciation based on the estimated useful life of respective years and as the change in estimated useful life is considered as change in estimate, accordingly there is no impact of this roll back. Similar approach has been followed with respect to intangible assets.

##### **b) Embedded lease**

For leases of both land and building elements, the Company has used Ind AS 101 exemption and has assessed the classification of each element as finance or an operating lease at the date of transition (April 1, 2016) to Ind AS on the basis of the facts and circumstance existing as at that date. For the purpose of Ind AS financial information for the financial years ended March 31, 2018, 2017 and 2016 the Company has continued with the classification of finance and operating leases on the date of transition.

##### **c) Business combinations**

Ind AS 103 Business Combinations has not been applied to acquisitions of subsidiaries, which are considered businesses under Ind AS that occurred before April 1, 2016. Use of this exemption means that the Indian GAAP carrying amounts of assets and liabilities, that are required to be recognised under Ind AS, is their deemed cost at the date of the acquisition. After the date of the acquisition, measurement is in accordance with respective Ind AS. The Group recognises all assets acquired and liabilities assumed in a past business combination, except (i) certain financial assets and liabilities that were derecognised and that fall under the derecognition exception, and (ii) assets (including goodwill) and liabilities that were not recognised in the acquirer's consolidated balance sheet under its previous GAAP and that would not qualify for recognition under Ind AS in the individual balance sheet of the acquiree.

Assets and liabilities that do not qualify for recognition under Ind AS are excluded from the opening Ind AS balance sheet. The Group did not recognise or exclude any previously recognised amounts as a result of Ind AS recognition requirements.

Ind AS 101 also requires that Indian GAAP carrying amount of goodwill must be used in the opening Ind AS balance sheet (apart from adjustments for goodwill impairment and recognition or derecognition of intangible assets). In accordance with Ind AS 101, the Group has tested goodwill for impairment at the date of transition to Ind AS. No goodwill impairment was deemed necessary at April 1, 2016.

#### **Exceptions from full retrospective application:**

##### **a) Estimates**

The estimates for the financial years ended March 31, 2018, 2017 and 2016 are consistent with those made for the same dates in accordance with the previous GAAP (after adjustments to reflect any differences in accounting policies) apart from the following items, which, under previous GAAP did not require estimation:

- Fair values of Financial Assets & Financial Liabilities
- Impairment of financial assets based on expected credit loss model

The estimates used by the Company to present these amounts in accordance with Ind AS reflect conditions at the date of transition to Ind AS, as of financial years ended March 31, 2018, 2017 and 2016.

##### **b) Classification and measurement of financial assets**

The Company has classified financial assets on the basis of the facts and circumstances that exist at the date of transition to Ind AS.

##### **c) De-recognition of financial assets and financial liabilities**

The Company has elected to apply the de-recognition requirements in Ind AS 109 prospectively for transactions occurring on or after April 1, 2016.

##### **d) Derivative Accounting**

The Company uses derivative financial instruments, such as forward currency contracts to hedge its foreign currency risks respectively. Under Indian GAAP, there is no mandatory standard that deals comprehensively with hedge accounting, which has resulted in the adoption of varying practices. The Company has designated various economic hedges and applied economic hedge accounting principles to avoid profit or loss mismatch. All the hedges designated under Indian GAAP are of types which qualify for hedge accounting in accordance with Ind AS 109 also. Moreover, the Company, before the date of transition to Ind AS, has designated a transaction as hedge and also meets all the conditions for hedge accounting in Ind AS 109. Consequently, the Company continues to apply hedge accounting after the date of transition to Ind AS.

**UNIPARTS INDIA LIMITED**  
**Annexure VI : Notes to Restated Consolidation Financial Information**  
**(All amounts in millions of INR, unless stated otherwise)**

**40. Reconciliation of equity and total comprehensive income**

Reconciliation of equity as March 31, 2018, 2017 and 2016:

Particulars	Notes	As at March 31, 2018	As at March 31,	As at March 31,
			2017	2016
			Proforma Ind AS	Proforma Ind AS
<b>Equity reported under Indian GAAP</b>		<b>3,662.03</b>	<b>3,201.53</b>	<b>2,947.25</b>
<b>Ind AS Adjustments</b>				
Preliminary expenses pending write off	3	(0.02)	(0.02)	(0.02)
Prior period Items	5	1.70	6.99	3.13
Leasehold land accounted for as Finance Lease	2	(17.91)	(11.70)	(5.49)
Income tax effect on Ind AS adjustments	7	(0.67)	(15.38)	-
<b>Equity as reported under Ind-AS</b>		<b>3,645.13</b>	<b>3,181.42</b>	<b>2,944.87</b>
<b>Restatement Adjustment</b>				
Tax adjustments - pertaining to earlier years	5	(0.03)	(2.89)	(2.89)
<b>Total Restatement Adjustment</b>		<b>(0.03)</b>	<b>(2.89)</b>	<b>(2.89)</b>
<b>Total Equity</b>		<b>3,645.10</b>	<b>3,178.53</b>	<b>2,941.98</b>

Reconciliation of total comprehensive income for the year ended March 31, 2018, 2017 and 2016:

Particulars	Notes	For the year ended	For the year ended	For the year ended
		March 31, 2018	March 31, 2017	March 31, 2016
			Proforma Ind AS	Proforma Ind AS
<b>Profit after tax as per Previous GAAP</b>		<b>524.36</b>	<b>304.22</b>	<b>469.09</b>
<b>Ind AS Adjustments:</b>				
Prior period Items	5	(5.28)	3.86	(0.92)
Leasehold land accounted for as Finance Lease	2	(6.21)	(6.21)	(5.49)
Income tax effect on Ind AS adjustments	7	14.72	(15.38)	-
Exchange differences in translating the financial statements of foreign operations	6	(64.14)	1.80	(80.91)
<b>Total comprehensive income as per Ind AS</b>		<b>463.45</b>	<b>288.29</b>	<b>381.77</b>
<b>Restatement Adjustment</b>				
Tax adjustments - pertaining to earlier years	6	2.83	-	(0.18)
<b>Total restated comprehensive income for the year</b>		<b>466.28</b>	<b>288.29</b>	<b>381.59</b>

**UNIPARTS INDIA LIMITED**  
**Annexure VI : Notes to Restated Consolidated Financial Information**  
**(All amounts in millions of INR, unless stated otherwise)**

**Reconciliation of equity and statement of profit and loss (Contd.):**

Reconciliation of equity as at March 31, 2016 - Proforma Ind AS

<b>Particulars</b>	<b>Notes</b>	<b>Amount as Per Indian GAAP*</b>	<b>Ind AS Adjustment</b>	<b>Restatement</b>	<b>Restated Ind AS</b>
<b>ASSETS</b>					
<b>I. Non-current assets</b>					
(a) Property, plant and equipment	2	1,932.97	(5.48)	-	1,927.48
(b) Capital work-in-progress		20.18	-	-	20.18
(c) Goodwill		598.33	-	-	598.33
(d) Other Intangible assets		30.49	-	-	30.49
(e) Intangible assets under development		4.48	-	-	4.48
(f) Financial assets					
(i) Loans		2.48	-	-	2.48
(ii) Other non-current financial assets	1	41.27	(2.91)	-	38.38
(g) Income Tax Assets (net)		138.00	-	-	138.00
(h) Other non-current assets	3	11.51	(0.02)	-	11.49
<b>II. Current assets</b>					
(a) Inventories		2,287.21	-	-	2,287.21
(b) Financial assets					
(i) Trade receivables	5,10	961.83	21.20	-	983.03
(ii) Derivative instruments		31.34	-	-	31.34
(iii) Cash and cash equivalents		49.65	-	-	49.65
(iv) Other bank balances		1.02	-	-	1.02
(v) Loans		-	-	-	-
(vi) Other current financial assets		0.62	-	-	0.62
(c) Other current assets	1,3	366.02	3.26	-	369.28
<b>Total Assets</b>		<b>6,477.40</b>	<b>16.05</b>	<b>-</b>	<b>6,493.46</b>
<b>EQUITY AND LIABILITIES</b>					
<b>Equity</b>					
(a) Equity share capital		446.20	-	-	446.20
(b) Other equity	3,5	2,501.05	(2.38)	(2.89)	2,495.78
<b>Total equity</b>		<b>2,947.25</b>	<b>(2.38)</b>	<b>(2.89)</b>	<b>2,941.98</b>
<b>Liabilities</b>					
<b>I. Non-current liabilities</b>					
(a) Financial liabilities					
(i) Borrowings		298.19	-	-	298.19
(b) Provisions		61.64	-	-	61.64
(c) Deferred tax liabilities (net)		269.38	-	-	269.38
(d) Other non-current liabilities		40.55	-	-	40.55
<b>II. Current liabilities</b>					
(a) Financial liabilities					
(i) Borrowings	10	1,850.76	21.33	-	1,872.09
(ii) Trade payables		578.46	-	-	578.46
(iii) Other current financial liabilities		133.65	-	-	133.65
(b) Provisions		45.61	-	-	45.61
(c) Other current liabilities	5	209.18	(2.89)	-	206.29
(d) Current Tax Liabilities (net)	5	42.73	-	2.89	45.62
<b>Total liabilities</b>		<b>3,530.15</b>	<b>18.43</b>	<b>2.89</b>	<b>3,551.48</b>
<b>Total Equity and Liabilities</b>		<b>6,477.40</b>	<b>16.05</b>	<b>-</b>	<b>6,493.46</b>

\* The previous GAAP figures have been reclassified to confirm to Ind AS presentation requirements for the purpose of this note.

**UNIPARTS INDIA LIMITED**
**Annexure VI : Notes to Restated Consolidated Financial Information**

(All amounts in millions of INR, unless stated otherwise)

**Reconciliation of equity and statement of profit and loss (Contd.):**

Reconciliation of Statement of profit and loss for the year ended March 31, 2016 - Proforma Ind AS

Particulars	Notes	Amount as Per Indian GAAP	Ind AS Adjustments	Restatement	Restated Ind AS
<b>Income</b>					
Revenue from Operations	4	7,688.97	106.23	-	7,795.20
Other Income	1	19.76	0.47	-	20.23
<b>Total Income (I)</b>		<b>7,708.73</b>	<b>106.70</b>	-	<b>7,815.43</b>
<b>Expenses</b>					
Cost of raw materials and components consumed		2,813.98	-	-	2,813.98
Purchase of stock in trade	5	3.03	-	-	3.03
Changes in Inventory		(52.59)	-	-	(52.59)
Excise duty on sale of goods	4	-	106.35	-	106.35
Employee benefits expense	5,6	1,604.51	(8.75)	-	1,595.76
Finance costs		100.48	-	-	100.48
Depreciation and amortisation expense	2	179.41	5.49	-	184.89
Other expenses	1,5,6	2,414.53	31.50	-	2,446.03
<b>Total expenses (II)</b>		<b>7,063.35</b>	<b>134.59</b>	-	<b>7,197.93</b>
<b>Profit before exceptional, Prior Period items and tax [I - II]</b>					
Prior Period Items	5	(0.21)	0.21	-	-
Exceptional items gain/(loss)		-	-	-	-
Provision for Doubtful Debts Written Back	5	(3.84)	3.84	-	-
<b>Profit before tax</b>		<b>649.43</b>	<b>(31.93)</b>	-	<b>617.50</b>
<b>Tax expense</b>					
<b>Current tax</b>					
For Current year	6,7,5	141.38	(10.69)	6.44	137.13
For earlier years	5	6.26	-	(6.26)	-
MAT credit		33.55	-	-	33.55
Deferred tax (Credit)/Charge	6	(0.85)	0.56	-	(0.29)
<b>Total tax expense</b>		<b>180.34</b>	<b>(10.13)</b>	<b>0.18</b>	<b>170.39</b>
<b>Profit for the year</b>		<b>469.09</b>	<b>(21.80)</b>	<b>(0.18)</b>	<b>447.12</b>
<b>Other comprehensive income</b>					
<b>a) Other Comprehensive Income to be reclassified to profit or loss in subsequent period</b>					
- Net movement on cash flow hedges	6	-	31.34	-	31.34
- Exchange differences in translating the financial statements of foreign operations		-	(80.92)	-	(80.92)
- Income tax effect		-	10.69	-	10.69
		-	<b>(60.27)</b>	-	<b>(60.27)</b>
<b>b) Other Comprehensive Income not to be reclassified to profit or loss in subsequent period</b>					
- Re-measurement gains / (losses) of defined benefit plans		-	(5.82)	-	(5.82)
- Income tax effect		-	(0.56)	-	(0.56)
		-	<b>(5.26)</b>	-	<b>(5.26)</b>
<b>Other comprehensive income for the year (a+b)</b>		-	<b>(65.53)</b>	-	<b>(65.53)</b>
<b>Total comprehensive income for the year</b>		-	<b>(87.33)</b>	<b>(0.18)</b>	<b>381.59</b>



**UNIPARTS INDIA LIMITED**  
**Annexure VI : Notes to Restated Consolidated Financial Information**  
**(All amounts in millions of INR, unless stated otherwise)**

**Reconciliation of equity and statement of profit and loss (Contd.):**

Reconciliation of equity as at March 31, 2017-Proforma Ind AS

Particulars	Notes	Amount as Per Indian GAAP*	Ind AS Adjustment	Restatement	Restated Ind AS
<b>ASSETS</b>					
<b>I. Non-current assets</b>					
(a) Property, plant and equipment	2	1,896.38	(11.69)	-	1,884.69
(b) Capital work-in-progress		100.10	-	-	100.10
(c) Goodwill		597.35	-	-	597.35
(d) Other Intangible assets		21.16	-	-	21.16
(e) Intangible assets under development		18.01	-	-	18.01
(f) Financial assets					
(i) Loans		1.87	-	-	1.87
(ii) Other non-current financial assets	1	40.78	(2.42)	-	38.36
(g) Income Tax Assets (net)		82.68	-	-	82.68
(h) Other non-current assets	3	27.39	(0.02)	-	27.36
<b>II. Current assets</b>					
(a) Inventories		2,273.54	-	-	2,273.54
(b) Financial assets					
(i) Trade receivables	10	978.48	29.77	-	1,008.25
(ii) Derivative instruments		44.90	-	-	44.90
(iii) Cash and cash equivalent		54.59	-	-	54.59
(iv) Other bank balances		1.77	-	-	1.77
(v) Other non-current financial assets		0.52	-	-	0.52
(c) Other current assets	1,3	301.77	4.01	-	305.79
<b>Total Assets</b>		<b>6,441.29</b>	<b>19.65</b>	<b>-</b>	<b>6,460.94</b>
<b>EQUITY AND LIABILITIES</b>					
<b>Equity</b>					
(a) Equity share capital		446.20	-	-	446.20
(b) Other equity	3,5	2,755.33	(20.12)	(2.89)	2,732.33
<b>Total equity</b>		<b>3,201.53</b>	<b>(20.12)</b>	<b>(2.89)</b>	<b>3,178.53</b>
<b>LIABILITIES</b>					
<b>I. Non-current liabilities</b>					
(a) Financial liabilities					-
(i) Borrowings		178.67	-	-	178.67
(b) Provisions		83.31	-	-	83.31
(c) Deferred tax liabilities (net)	7	273.07	15.39	-	288.46
(d) Other non-current liabilities		29.74	-	-	29.74
<b>II. Current liabilities</b>					
(a) Financial liabilities					
(i) Borrowings	10	1,599.33	29.77	-	1,629.10
(ii) Trade payables		605.10	-	-	605.10
(iii) Other current financial liabilities		140.09	-	-	140.09
(b) Provisions		51.37	-	-	51.37
(c) Other current liabilities	5	270.74	(5.40)	-	265.34
(d) Current Tax Liabilities (net)	5	8.34	-	2.89	11.23
<b>Total liabilities</b>		<b>3,239.76</b>	<b>39.76</b>	<b>2.89</b>	<b>3,282.41</b>
<b>Total Equity and Liabilities</b>		<b>6,441.29</b>	<b>19.65</b>	<b>-</b>	<b>6,460.94</b>

\* The previous GAAP figures have been reclassified to confirm to Ind AS presentation requirements for the purpose of this note.

**UNIPARTS INDIA LIMITED**
**Annexure VI : Notes to Restated Consolidated Financial Information**

(All amounts in millions of INR, unless stated otherwise)

**Reconciliation of equity and statement of profit and loss (Contd.):**

Reconciliation of Statement of profit and loss for the year ended March 31, 2017-Proforma Ind AS

Particulars	Notes	Amount as Per Indian GAAP	Ind AS Adjustments	Restatement	Restated Ind AS
<b>Income</b>					
Revenue from Operations	4	6,924.99	106.48	-	7,031.47
Other Income	1	18.61	2.11	-	20.72
<b>Total Income (I)</b>		<b>6,943.60</b>	<b>108.58</b>	-	<b>7,052.19</b>
<b>Expenses</b>					
Cost of raw materials and components consumed		2,389.33	-	-	2,389.33
Purchase of stock in trade	5	1.37	-	-	1.37
Changes in Inventory		27.07	(0.01)	-	27.06
Excise duty on sale of goods	4	-	106.47	-	106.47
Employee benefits expense	5,6	1,597.04	(15.24)	-	1,581.81
Finance costs		86.55	-	-	86.55
Depreciation and amortisation expense	2	191.45	6.21	-	197.66
Other expenses	1,5,6	2,221.90	44.96	-	2,266.87
<b>Total expenses (II)</b>		<b>6,514.71</b>	<b>142.40</b>	-	<b>6,657.12</b>
Profit before exceptional, Prior Period items and tax [I - II]		428.89	(33.82)	-	395.07
Prior Period Items	5	(3.13)	3.13	-	-
Exceptional items gain/(loss)		-	-	-	-
<b>Profit before tax</b>		<b>432.02</b>	<b>(36.95)</b>	-	<b>395.07</b>
<b>Tax expense</b>					
Current tax					
For Current year	5	100.02	-	0.08	100.09
For earlier years	5	0.08	-	(0.08)	-
MAT credit		20.64	-	-	20.64
Deferred tax (Credit)/Charge	7	7.06	2.08	-	9.14
<b>Total tax expense</b>		<b>127.80</b>	<b>2.08</b>	-	<b>129.87</b>
<b>Profit for the year</b>		<b>304.22</b>	<b>(39.03)</b>	-	<b>265.20</b>
<b>Other comprehensive income</b>					
a) Other Comprehensive Income to be reclassified to profit or loss in subsequent period					
	6				
- Net movement on cash flow hedges		-	44.90	-	44.90
- Exchange differences in translating the financial statements of foreign operations		-	1.80	-	1.80
- Income tax effect		-	15.38	-	15.38
		-	<b>31.32</b>	-	<b>31.32</b>
b) Other Comprehensive Income not to be reclassified to profit or loss in subsequent period					
- Re-measurement gains / (losses) of defined benefit plans		-	(10.31)	-	(10.31)
- Income tax effect		-	(2.08)	-	(2.08)
		-	<b>(8.23)</b>	-	<b>(8.23)</b>
<b>Other comprehensive income for the year (a+b)</b>		-	<b>23.08</b>	-	<b>23.08</b>
<b>Total comprehensive income for the year</b>		-	<b>(15.94)</b>	-	<b>288.28</b>

**UNIPARTS INDIA LIMITED**
**Annexure VI : Notes to Restated Consolidated Financial Information**

(All amounts in millions of INR, unless stated otherwise)

**Reconciliation of equity and statement of profit and loss (Contd.):**

Reconciliation of equity as at March 31, 2018

Particulars	Notes	Amount as Per Indian GAAP*	Ind AS Adjustments	Restatement	Restated Ind AS
<b>ASSETS</b>					
<b>I. Non-current assets</b>					
(a) Property, plant and equipment	2	1,931.61	(17.90)	-	1,913.72
(b) Capital work-in-progress		279.58	4.37	-	283.95
(c) Goodwill		584.82	-	-	584.82
(d) Other Intangible assets		17.77	-	-	17.77
(e) Intangible assets under development		21.60	-	-	21.60
(e) Financial assets					-
(i) Loans		2.27	-	-	2.27
(ii) Other non-current financial assets	1	53.45	(5.00)	-	48.46
(f) Income Tax Assets (net)		96.40	-	-	96.40
(g) Other non-current assets	3	54.76	(0.02)	-	54.73
<b>II. Current assets</b>					
(a) Inventories		3,041.80	-	-	3,041.80
(b) Financial assets					-
(i) Trade receivables	10	1,119.13	37.87	-	1,156.99
(ii) Cash and cash equivalent		90.44	-	-	90.44
(iii) Bank Balances other than (ii) above		1.05	-	-	1.05
(iv) Derivative instruments		1.92	-	-	1.92
(v) Other non-current financial assets		0.63	-	-	0.63
(c) Other current assets	1,3	415.83	4.98	-	420.81
<b>Total Assets</b>		<b>7,713.06</b>	<b>24.30</b>	<b>-</b>	<b>7,737.36</b>
<b>EQUITY AND LIABILITIES</b>					
<b>Equity</b>					
(a) Equity share capital		446.20	-	-	446.20
(b) Other equity	3,5	3,215.83	(16.90)	(0.03)	3,198.90
<b>Total equity</b>		<b>3,662.03</b>	<b>(16.90)</b>	<b>(0.03)</b>	<b>3,645.10</b>
<b>LIABILITIES</b>					
<b>I. Non-current liabilities</b>					
(a) Financial liabilities					
(i) Borrowings		242.98	-	-	242.98
(b) Provisions		112.97	-	-	112.97
(c) Deferred tax liabilities (net)	7	247.83	0.67	-	248.50
(d) Other non-current liabilities	9	18.45	4.29	-	22.75
<b>II. Current liabilities</b>					
(a) Financial liabilities					
(i) Borrowings	10	2,065.69	37.87	-	2,103.56
(ii) Trade payables		875.48	-	-	875.48
(iii) Other current financial liabilities (other than (c))		124.71	-	-	124.71
(b) Other current liabilities		293.97	(1.63)	-	292.33
(c) Provisions		55.33	-	-	55.33
(d) Current Tax Liabilities (net)		13.62	-	0.03	13.65
<b>Total liabilities</b>		<b>4,051.03</b>	<b>41.20</b>	<b>0.03</b>	<b>4,092.26</b>
<b>Total Equity and Liabilities</b>		<b>7,713.06</b>	<b>24.30</b>	<b>-</b>	<b>7,737.36</b>

\* The previous GAAP figures have been reclassified to confirm to Ind AS presentation requirements for the purpose of this note.

**UNIPARTS INDIA LIMITED**  
**Annexure VI : Notes to Restated Consolidated Financial Information**  
**(All amounts in millions of INR, unless stated otherwise)**

**Reconciliation of equity and statement of profit and loss (Contd.):**

Reconciliation of Statement of profit and loss for the year ended March 31, 2018

Particulars	Notes	Amount as Per Indian GAAP	Ind AS Adjustments	Restatement	Restated Ind AS
<b>Income</b>					
Revenue from Operations	4	8,417.82	44.04	-	8,461.86
Other Income	1	8.60	0.71	-	9.30
<b>Total Income (I)</b>		<b>8,426.42</b>	<b>44.75</b>	-	<b>8,471.16</b>
<b>Expenses</b>					
Cost of raw materials and components consumed		3,369.36	-	-	3,369.36
Changes in Inventory		(548.01)	-	-	(548.01)
Excise duty on sale of goods	4	-	44.04	-	44.04
Employee benefits expense	5,6	1,780.37	(10.78)	-	1,769.58
Finance costs		90.32	-	-	90.32
Depreciation and amortisation expense	2	202.31	6.21	-	208.52
Other expenses	1,5,6	2,828.47	2.63	-	2,831.10
<b>Total expenses (II)</b>		<b>7,722.82</b>	<b>42.10</b>	-	<b>7,764.92</b>
Profit before exceptional, Prior Period items and tax [I - II]		703.60	2.65	-	706.25
Prior Period Items	5	(6.99)	6.99	-	-
Exceptional items gain/(loss)		-	-	-	-
<b>Profit before tax</b>		<b>710.59</b>	<b>(4.34)</b>	-	<b>706.25</b>
<b>Tax expense</b>					
Current tax					
For Current year	5	194.50	-	0.64	195.14
For earlier years	5	3.49	-	(3.49)	-
MAT credit		13.63	-	-	13.63
Deferred tax (Credit)/Charge	7	(25.39)	(12.48)	-	(37.87)
<b>Total tax expense</b>		<b>186.23</b>	<b>(12.48)</b>	<b>(2.85)</b>	<b>170.90</b>
<b>Profit for the year</b>		<b>524.36</b>	<b>8.14</b>	<b>2.85</b>	<b>535.35</b>
<b>Other comprehensive income</b>					
a) Other Comprehensive Income to be reclassified to profit or loss in subsequent period					
	6				
- Net movement on cash flow hedges		-	1.92	-	1.92
- Exchange differences in translating the financial statements of foreign operations		-	(64.14)	-	(64.14)
- Income tax effect		-	0.67	-	0.67
		-	<b>(62.89)</b>	-	<b>(62.89)</b>
b) Other Comprehensive Income not to be reclassified to profit or loss in subsequent period					
- Re-measurement gains / (losses) of defined benefit plans		-	(9.07)	-	(9.07)
- Income tax effect		-	(2.90)	-	(2.90)
		-	<b>(6.17)</b>	-	<b>(6.17)</b>
<b>Other comprehensive income for the year (a+b)</b>		-	<b>(69.06)</b>	-	<b>(69.06)</b>
<b>Total comprehensive income for the year</b>		-	<b>(60.92)</b>	<b>2.85</b>	<b>466.27</b>

**UNIPARTS INDIA LIMITED**  
**Annexure VI : Notes to Restated Consolidated Financial Information**  
**(All amounts in millions of INR, unless stated otherwise)**

**Notes to reconciliation**

**1. Financial Instruments**

Under Indian GAAP, the Company accounted for Security Deposits and other receivable balances as Loans and Advances measured at cost. Under Ind AS, such balances are classified and measured at amortized cost using effective interest rate method. At the date of transition to Ind AS, the difference between amortized cost and the Indian GAAP carrying amount has been recognised in other equity (net of related deferred tax).

Under Indian GAAP the company has accounted for security deposit at their carrying value. Under Ind AS the company has recognised the amount of security deposits for rented property at its present value on transition date and the balance amount is increased with advance rent. The resulting impact of INR 2.91 million for March 31, 2016 and INR 2.42 million for March 31, 2017 INR 5.00 million for March 31, 2018 have been reclassified to Advance Rent. However the net effect shall be nil due to this adjustment.

As per Ind AS the amount of interest is recognised with corresponding increase in Security deposit at the rate it was discounted. The amount of rent is also increased with same amount and the corresponding decrease was recorded in advance rent. The net effect on Profit and Loss and current asset was nil.

**2. Property, Plant and Equipment's**

Under Indian GAAP, no depreciation was required to be charged on land. However under Ind AS 16, Land which has limited useful life is subject to depreciation. Accordingly company has depreciated its leasehold land, hence the amount of PPE is decreased and charged to depreciation with INR 5.49 million for March 31, 2016, INR 6.21 million for March 31, 2017, INR 6.21 million for March 31, 2018.

**3. Other Current Assets**

The amount of Preliminary expenses are written off on transition date as they cannot be deferred as per para 69 of IND AS 38 and hence the amount of current assets is decreased and same is recognised in other equity.

**4. Revenue**

Under Indian GAAP, revenue from sale of products was presented excluding excise duty. Under Ind AS, revenue from sale of products is presented inclusive of excise duty. Excise duty paid is presented on the face of the statement of profit and loss as part of expenses. This change has resulted in an increase in total revenue and total expenses for the year ended March 31, 2016 by INR 106.350 million and March 31, 2017 by INR 106.47 million, March 31, 2018 INR 44.04 There is no impact on total equity and profits.

**5. Prior period Item**

In the Audited financial statements for the period ended September 30, 2018 and years ended March 31, 2018, March 31, 2017, March 31, 2016 the Company had accounted for tax for earlier years. Accordingly, in the preparation of the Restated financial information, the effect of the prior period items has been appropriately adjusted to the results of the respective year to which these items pertain to.

The reversal of provisions relating to prior period are adjusted from retained earnings on transition date and there after from the expense itself due to which profits are decreased with same amount i.e. INR 3.13 million for March 31, 2016, INR 6.99 million for March 31, 2017 and INR 1.70 for March 31, 2018.

**6. Other comprehensive income**

Under Ind AS, Certain items are to be classified through other comprehensive income, Accordingly the company has classified those income/expenses through OCI reserves (net of tax).

**7. Deferred tax**

Indian GAAP requires deferred tax accounting using the income statement approach, which focuses on differences between taxable profits and accounting profits for the period. Ind AS 12 requires entities to account for deferred taxes using the balance sheet approach, which focuses on temporary differences between the carrying amount of an asset or liability in the balance sheet and its tax base. This has resulted in recognition of deferred tax on new temporary differences which was not required under Indian GAAP.

In addition, the various transitional adjustments lead to temporary differences. According to the accounting policies, the Company has to account for such differences. Deferred tax adjustments are recognised in correlation to the underlying transaction either in other equity or a separate component of equity.

**8. Statement of Cash flows**

The transition from Indian GAAP to Ind AS has no had material impact on the statement of cash flows.

**9. Government Grant**

The Government grant related to property, plant and equipment was offset with the cost under previous GAAP. Under Ind AS the government grant related to property, plant and equipment is recognized as deferred income and is being amortized over the useful life of the asset in proportion in which the related depreciation expense is recognized.

**10. Bill of exchange discounted**

Under IGAAP, trade receivables derecognised by way of bills of exchange have been shown as contingent liability. Under Ind AS, due to application of Ind AS 109 derecognition requirements, the trade receivables have been restated with corresponding recognition of short term borrowings of INR 37.87 Million, INR 29.77 Million, INR 21.33 Million as on March 31, 2018, March 31, 2017 and March 31, 2016 respectively.

**UNIPARTS INDIA LIMITED**  
**Annexure VI : Notes to Restated Consolidated Financial Information**  
**(All amounts in millions of INR, unless stated otherwise)**

**41. Hedging activities and derivatives**

The Company uses foreign currency denominated borrowings and foreign exchange forward contracts for the purpose of hedging its currency risks. These contracts are not intended for trading or speculation. The foreign exchange forward contracts are designated as cash flow hedges.

**Cash flow hedges**

Foreign exchange forward contracts measured at fair value through OCI are designated as hedging instruments in cash flow hedges of forecast sales in US dollar. These forecast transactions are highly probable.

While the Company also enters into other foreign exchange forward contracts with the intention to reduce the foreign exchange risk of expected sales and purchases, these other contracts are not designated in hedge relationships and are measured at fair value through profit or loss.

The foreign exchange forward contract balances vary with the level of expected foreign currency sales and purchases and changes in foreign exchange forward rates.

The terms of the foreign currency forward contracts match the terms of the expected highly probable forecast transactions. As a result, no hedge ineffectiveness arise requiring recognition through profit or loss. Notional amounts of outstanding forward contracts are as follows :

Nature of instrument	Currency	Purpose	As at September 30, 2018		As at March 31, 2018		As at March 31, 2017 Proforma Ind AS		As at March 31, 2016 Proforma Ind AS	
			Foreign Currency in Million	in INR million	Foreign Currency in Million	in INR million	Foreign Currency in Million	in INR million	Foreign Currency in Million	in INR million
Forward contract	USD	Hedging of highly probable sales	15.30	1,058.26	9.50	631.34	10.83	754.58	23.35	1,616.83
			<b>15.30</b>	<b>1,058.26</b>	<b>9.50</b>	<b>631.34</b>	<b>10.83</b>	<b>754.58</b>	<b>23.35</b>	<b>1,616.83</b>

The cash flow hedges of the expected future sales during the period ended September 30, 2018 were assessed to be highly effective and a net unrealised loss of INR 43.47 million, with a deferred tax asset of INR 22.25 million relating to the hedging instruments, is included in OCI. Comparatively, the cash flow hedges of the expected future sales during the year ended March 31, 2018 were assessed to be highly effective and a net unrealised gain of INR 1.26 million, with a deferred tax liability of INR 0.67, March 31, 2017 net unrealised gain of INR 29.52 million with a deferred tax liability of INR 15.38 million, for the year ended March 31, 2016 net Unrealised gain of INR 20.65 million with a tax liability of INR 10.69 million was included in OCI in respect of these contracts.

The amount removed from OCI during the year and recognised in the statement of profit & loss for the period ended September 30, 2018 is detailed in Note 30 totaling INR 1.26 million (net of tax) (March 31, 2018: INR 29.52 million (net of tax) (March 31, 2017: INR 20.65 million), (March 31, 2016: INR 11.58 million). The amounts retained in OCI at September 30, 2018 are expected to mature and affect the statement of profit and loss till year ended September 30, 2019.

Reclassifications to profit or loss during the year gains or losses included in OCI are shown in Note 30.

**UNIPARTS INDIA LIMITED**  
**Annexure VI : Notes to Restated Consolidated Financial Information**  
**(All amounts in millions of INR, unless stated otherwise)**

**42. Financial Risk management objectives and policies**

The Company's principal financial liabilities other than derivatives, comprise loans and borrowings, trade payables, employees related payables and other payable. The main purpose of these financial liabilities is to finance the Company's operations. The Company's principal financial assets include loan to employees, trade receivables & other receivables and cash and bank balances that derive directly from its operations.

The Company is exposed to market risk, credit risk and liquidity risk. The Company's senior management oversees the management of these risks. The Company's senior management is supported by a Audit committee that advises on financial risks and the appropriate financial risk governance framework for the Company. The Audit committee provides assurance that the Company's financial risk activities are governed by appropriate policies and procedures and that financial risks are identified, measured and managed in accordance with the Company's policies and risk objectives. All derivative activities for risk management purposes are carried out by experienced members from the senior management who have the relevant expertise, appropriate skills and supervision. It is the Company's policy that no trading in derivatives for speculative purposes may be undertaken. The Board of Directors reviews and agrees policies for managing each of these risks, which are summarised as below.

**Market risk**

Market risk is the risk that the fair value of future cash flows of a financial instrument will fluctuate because of changes in market prices. Market prices are subject to commodity price risk, foreign exchange risk and interest rate risk.

The financial instruments that are affected by these include loans and borrowing, deposits, available-for-sale investments and derivative financial instruments. We, from time to time, undertake analysis in relation to the amount of our net debt, the ratio of fixed to floating interest rates of our debt and our financial instruments that are in foreign currencies. We use derivative financial instruments such as foreign exchange contracts to manage our exposures to foreign exchange fluctuations.

**Interest rate risk**

Interest rate risk is the risk that the fair value or future cash flows of a financial instrument will fluctuate because of changes in market interest rates. The Company's exposure to the risk of changes in market interest rates relates primarily to the Company's long-term debt obligations with floating interest rates. The interest rate on remaining loans (except vehicle loans), although fixed, is subject to periodic review by lending banks / financial institutions in relation to their respective base lending rates, which may vary over a period result of any change in the monetary policy of the Reserve Bank of India.

Particulars	As at September	As at March 31,	As at March 31,	As at March 31,
	30, 2018	2018	2017	2016
			Proforma Ind AS	Proforma Ind AS
<b>Variable rate borrowings</b>				
Long Term	-	-	-	181.25
Short Term	2,758.05	2,065.69	1,599.33	1,850.76
<b>Total Variable rate borrowings</b>	<b>2,758.05</b>	<b>2,065.69</b>	<b>1,599.33</b>	<b>2,032.01</b>
<b>Fixed rate borrowings</b>				
Long Term	339.59	367.69	318.77	250.59
Short Term	-	-	-	-
<b>Total fixed rate borrowings</b>	<b>339.59</b>	<b>367.69</b>	<b>318.77</b>	<b>250.59</b>
<b>Total Borrowings*</b>	<b>3,097.64</b>	<b>2,433.38</b>	<b>1,918.10</b>	<b>2,282.60</b>

\* Excluding Bills discounting with Bank.

**Interest rate sensitivity**

Variable interest rate loans are exposed to Interest rate risk, the impact on profit or loss before tax may be as follows:

Particulars	Effect on profit and equity			
	As at September	As at March 31,	As at March 31,	As at March 31,
	30, 2018	2018	2017	2016
			Proforma Ind AS	Proforma Ind AS
Interest rate - increase by 100 basis points (100 bps)*	(27.58)	(20.66)	(15.99)	(20.32)
Interest rate - decrease by 100 basis points (100 bps)*	27.58	20.66	15.99	20.32

\* Holding all other variable constant

The assumed movement in basis points for the interest rate sensitivity analysis is based on the currently observable market environment, showing a significantly higher volatility than in prior years.

**UNIPARTS INDIA LIMITED**  
**Annexure VI : Notes to Restated Consolidated Financial Information**  
**(All amounts in millions of INR, unless stated otherwise)**

**Foreign currency risk**

Foreign currency risk is the risk that the fair value or future cash flows of an exposure will fluctuate because of changes in foreign exchange rates. The Company's exposure to the risk of changes in foreign exchange rates relates primarily to the Company's export revenue and long term foreign currency borrowings.

The Company have long term agreements with its major customers, the company face foreign exchange risk in respect of (i) our foreign currency loans, in respect of which selectively hedge currency exchange rate risk, (ii) currency mismatches between income and expenditures, which the company seek to manage as much as possible by matching income currency to expenditure currency, and (iii) currency translation for the purpose of preparing consolidated financial statements, on account of global operations.

The year end foreign currency exposures that have not been hedged by a derivative instrument or otherwise are given below:

Particulars	Currency	Description	As at September	As at March 31,	As at March 31,	As at March 31,
			30, 2018	2018	2017	2016
					Proforma Ind AS	Proforma Ind AS
<b>Receivables</b>	USD	Sale	0.96	1.62	1.68	0.43
	EUR	Sale	3.99	3.74	4.03	1.07
	JPY	Sale	22.61	21.71	20.00	25.54
	AUD	Sale	0.31	0.35	0.30	0.16
	GBP	Sale	0.25	0.30	0.24	0.21
<b>Payables</b>	USD	Purchase	0.77	1.08	1.42	0.03
	EUR	Purchase	0.06	0.05	0.00	0.00
<b>Loans</b>	USD	PCFC Loan/PSFC Loan	12.18	11.08	9.79	11.59
	USD	FCTL Loan	3.30	3.75	2.35	1.13
<b>Bank</b>	USD	EEFC	0.04	0.00	0.00	-
	EUR	EEFC	-	-	-	0.01
<b>Other Receivable</b>	USD		0.06	0.07	0.01	0.01
	EUR		-	-	0.00	0.00
	GBP		-	-	-	-
<b>Other Payables</b>	USD		-	-	0.01	0.00
	EUR		-	-	-	-
	AUD		-	-	-	-
	JPY		3.83	2.47	1.84	2.71

**Foreign currency sensitivity**

With respect to the above unhedged exposure the sensitivity is as follows:

Particulars	Effect on profit and equity			
	As at September	As at March 31,	As at March 31,	As at March 31,
	30, 2018	2018	2017	2016
			Proforma Ind AS	Proforma Ind AS
INR/USD-Increase by 5%	(55.12)	(46.26)	(38.48)	(40.79)
INR/EUR-Increase by 5%	16.58	14.87	13.94	4.04
INR/GBP-Increase by 5%	1.19	1.38	0.95	1.00
INR/JPY-Increase by 5%	0.60	0.59	0.53	0.67
INR/AUD-Increase by 5%	0.80	0.88	0.75	0.40
INR/USD-Decrease by 5%	55.12	46.26	38.48	40.79
INR/EUR-Decrease by 5%	(16.58)	(14.87)	(13.94)	(4.04)
INR/GBP-Decrease by 5%	(1.19)	(1.38)	(0.95)	(1.00)
INR/JPY-Decrease by 5%	(0.60)	(0.59)	(0.53)	(0.67)
INR/AUD-Decrease by 5%	(0.80)	(0.88)	(0.75)	(0.40)

**Commodity price risk**

Commodity price risk is the possibility of impact from changes in the prices of raw materials such as steel, which we use in the manufacture of our products. While we seek to pass on input cost increases to our customers, we may not be able to fully achieve this in all situations or at all times



**UNIPARTS INDIA LIMITED**  
**Annexure VI : Notes to Restated Consolidated Financial Information**  
**(All amounts in millions of INR, unless stated otherwise)**

**Credit risk**

Credit risk is the risk that counterparty will not meet its obligations under a financial instrument or customer contract, leading to a financial loss. The Company is exposed to credit risk from its operating activities (primarily trade receivables) and from its financing activities, including deposits with banks and financial institutions, investment in mutual funds, other receivables and deposits, foreign exchange transactions and other financial instruments.

In relation to credit risk arising from financing activities, we monitor our credit spreads and financial strength on a regular basis, and based on our on-going assessment of counterparty risk, we adjust our exposure to various counterparties.

For the period / year September 30, 2018, March 31, 2018, 2017 and 2016 our provision for doubtful debts amounted to INR 6.39 million , INR 5.83 million , INR 4.19 million and INR 3.31 million respectively.

**Liquidity risk**

Liquidity risk is the risk that the Company will encounter difficulty in meeting the obligations associated with its financial liabilities that are settled by delivering cash or another financial asset. The Company's approach to managing liquidity is to ensure, as far as possible, that it will have sufficient liquidity to meet its liabilities when they are due, under both normal and stressed conditions, without incurring unacceptable losses or risking damage to the Company's reputation.

The Company manages liquidity risk by maintaining adequate reserves, banking facilities and reserve borrowing facilities, by continuously monitoring forecast and actual cash flows, and by matching the maturity profiles of financial assets and liabilities.

<b>Particulars</b>	<b>As at September 30, 2018</b>	<b>As at March 31, 2018</b>	<b>As at March 31, 2017 Proforma Ind AS</b>	<b>As at March 31, 2016 Proforma Ind AS</b>
Total Committed working capital limits from Banks	3,037.65	2,676.65	2,672.90	2,443.90
Utilized working capital limit	2,758.05	2,065.69	1,599.33	1,850.76
<b>Unutilized working capital limit</b>	<b>279.60</b>	<b>610.96</b>	<b>1,073.57</b>	<b>593.14</b>

**Maturities of financial liabilities**

The tables below analyse the Company's financial liabilities into relevant maturity groupings based on their contractual maturities. The amount disclosed in the table are the contractual undiscounted cash flow.

<b>Particulars</b>	<b>As at September 30, 2018</b>	<b>As at March 31, 2018</b>	<b>As at March 31, 2017 Proforma Ind AS</b>	<b>As at March 31, 2016 Proforma Ind AS</b>
<b>Long Term Borrowings</b>				
Upto 1 year	118.90	124.71	140.09	133.65
Between 1 to 5 years	220.70	242.98	178.67	298.19
Over 5 years	-	-	-	-
<b>Short Term Borrowings</b>				
Upto 1 year	2,758.05	2,065.69	1,629.10	1,872.09
Between 1 to 5 years	-	-	-	-
Over 5 years	-	-	-	-
<b>Trade Payables</b>				
Upto 1 year	1,052.31	875.48	605.10	578.46
Between 1 to 5 years	-	-	-	-
Over 5 years	-	-	-	-
<b>Total</b>	<b>4,149.96</b>	<b>3,308.86</b>	<b>2,552.96</b>	<b>2,882.39</b>

**UNIPARTS INDIA LIMITED**  
**Annexure VI : Notes to Restated Consolidated Financial Information**  
**(All amounts in millions of INR, unless stated otherwise)**

**43. Financial Instruments by category and Fair Value hierarchy**

Set out below, is a comparison by class of the carrying amounts and fair value of the Company's financial instruments, other than those with carrying amounts that are reasonable approximations of fair values:

Particulars	Level of Inputs used	Carrying Value				Fair Values			
		As at September 30, 2018	As at March 31, 2018	As at March 31, 2017 Proforma Ind AS	As at March 31, 2016 Proforma Ind AS	As at September 30, 2018	As at March 31, 2018	As at March 31, 2017 Proforma Ind AS	As at March 31, 2016 Proforma Ind AS
<b>Financial Assets</b>									
Loan to Employees	-	6.08	2.27	1.87	2.48	6.08	2.27	1.87	2.48
Security Deposits	-	49.97	48.37	38.30	38.33	49.97	48.37	38.30	38.33
Derivatives	Level 1	(65.72)	1.92	44.90	31.34	(65.72)	1.92	44.90	31.34
Trade Receivables	-	1,453.67	1,156.99	1,008.25	983.03	1,453.67	1,156.99	1,008.25	983.03
Cash & Bank Balances	-	102.66	91.49	56.36	50.67	102.66	91.49	56.36	50.67
Other Receivables	-	1.75	0.72	0.57	0.67	1.75	0.72	0.57	0.67
<b>Financial Liabilities</b>									
Borrowings	-	3,131.22	2,471.25	1,947.86	2,303.93	3,131.22	2,471.25	1,947.86	2,303.93
Trade Payables	-	1,058.56	875.48	605.10	578.46	1,058.56	875.48	605.10	578.46

The management assessed that the fair value of cash and cash equivalent, trade receivables, derivative instruments, trade payables and other current financial assets and liabilities approximate their carrying amounts largely due to the short term maturities of these instruments.

The fair value of the financial assets and liabilities is included at the amount at which the instrument could be exchanged in a current transaction between willing parties, other than in a forced or liquidation sale. The following methods and assumptions were used to estimate the fair values:

- Long-term fixed-rate and variable-rate receivables are evaluated by the Company based on parameters such as individual creditworthiness of the customer. Based on this evaluation, allowances are taken into account for the expected credit losses of these receivables.
- The fair value of other non-current financial liabilities and security deposits, is estimated by discounting future cash flows using 10 year government bond rates. In addition to being sensitive to a reasonably possible change in the forecast cash flows or the discount rate, the fair value of the equity instruments is also sensitive to a reasonably possible change in the growth rates.
- Further the management assessed that the fair value of loan to employees approximate their carrying amounts largely due to discounting at rates which are an approximation of current lending rates.
- The Company enters into derivative financial instruments with various counterparties, principally financial institutions with investment grade credit ratings. Foreign exchange forward contracts are valued using valuation techniques, which employs the use of market observable inputs. The most frequently applied valuation techniques include forward pricing using present value calculations. The models incorporate various inputs including the credit quality of counterparties, foreign exchange spot and forward rates, yield curves of the respective currencies, currency basis spreads between the respective currencies and forward rate curves of the underlying. All derivative contracts are fully cash collateralised, thereby eliminating both counterparty and the Company's own non-performance risk. As at September 30, 2018 the marked-to-market value of derivative asset positions is net of a credit valuation adjustment attributable to derivative counterparty default risk. The changes in counterparty credit risk had no material effect on the hedge effectiveness assessment for derivatives designated in hedge relationships and other financial instruments recognised at fair value.

**Reconciliation of fair value measurement of financial assets classified as FVTOCI:**

Particulars	As at September 30, 2018	As at March 31, 2018	As at March 31, 2017 Proforma Ind AS	As at March 31, 2016 Proforma Ind AS
Derivatives				
-Forward Currency Contra	(65.72)	1.92	44.90	31.34

**UNIPARTS INDIA LIMITED**  
**Annexure VI : Notes to Restated Consolidated Financial Information**  
**(All amounts in millions of INR, unless stated otherwise)**

**44. Capital management**

The capital includes issued equity capital and other equity reserves attributable to the equity holders of the company. The primary objective of the company's capital management is to maintain optimum capital structure to reduce cost of capital and to maximize the shareholder value.

The company manages its capital structure and makes adjustments in light of changes in economic conditions and the requirements of the financial covenants which otherwise would permit the banks to immediately call loans and borrowings. In order to maintain or adjust the capital structure, the company may adjust the dividend payment to shareholders, return capital to shareholders or issue new shares.

Particulars	As at September 30, 2018	As at March 31, 2018	As at March 31, 2017 Proforma Ind AS	As at March 31, 2016 Proforma Ind AS
<b>Borrowings</b>	3,131.22	2,471.25	1,947.86	2,303.93
Less: cash and other liquid assets	102.66	91.49	56.36	50.67
<b>Net Debt</b>	<b>3,028.56</b>	<b>2,379.75</b>	<b>1,891.50</b>	<b>2,253.26</b>
Equity	3,884.51	3,645.10	3,178.53	2,941.98
<b>Net Debt/Equity ratio</b>	<b>0.78</b>	<b>0.65</b>	<b>0.60</b>	<b>0.77</b>

No changes were made in the objectives, policies or processes for managing capital during the period ended September 30, 2018 and years ended March 31, 2018, March 31, 2017 and March 31, 2016.

**UNIPARTS INDIA LIMITED**
**Annexure VII : Statement on Adjustments to Audited Consolidation Financial Statements**

(All amounts in millions of INR, unless stated otherwise)

Summarized below are the restatement adjustments made to the audited financial statements for the financial year ended September 30, 2018, March 31, 2018, March 31, 2017 and March 31, 2016 and their impact on the profit / (loss) of the Company:

Particulars	Notes	As at September 30, 2018	As at March 31, 2018	As at March 31, 2017 Proforma Ind AS	As at March 31, 2016 Proforma Ind AS
Net profit after tax as per Adjusted Previous GAAP		-	524.36	304.22	469.09
<b>Ind AS Adjustments</b>					
Aggregate impact of all Ind AS adjustments (refer notes 39-40 for detailed explanation of transition from Previous GAAP to Ind AS), net of tax	39-40	-	(60.92)	(15.93)	(87.32)
<b>Net profit after tax as per Ind AS</b>		<b>441.74</b>	<b>463.44</b>	<b>288.29</b>	<b>381.77</b>
<b>(i) Material restatement adjustments</b>					
Tax adjustments - pertaining to earlier years	39-40	-	2.83	-	(0.18)
<b>(ii) Other adjustments</b>		-	-	-	-
<b>Total Impact of above adjustments</b>		<b>-</b>	<b>2.83</b>	<b>-</b>	<b>(0.18)</b>
<b>Net profit, as restated</b>		<b>441.74</b>	<b>466.27</b>	<b>288.29</b>	<b>381.59</b>

**Notes to above adjustments:-**

(i) The impact of prior period adjustments have been considered for disclosure under note 40 and have accordingly not been disclosed again.

**(ii) Material regroupings**

Appropriate adjustments have been made in the Restated Consolidation Financial Information, wherever required, by reclassification of the corresponding items of income, expenses, assets and liabilities, in order to bring them in line with the requirements of the Securities Exchange Board of India (Issue of Capital and Disclosure Requirements) Regulations, 2018 (as amended) and as per the audited financials of the Company for the year ended September 30, 2018 prepared in accordance with the Schedule III of the Companies Act, 2013.

(iii) Reconciliation of retained earnings as at April 1, 2015

	As at 1st April 2015
<b>A. Retained earnings as per Adjusted Previous GAAP computed</b>	2,152.32
Aggregate impact of all Ind AS adjustments, net of tax	1.32
<b>B. Total Ind AS adjustments</b>	<b>1.32</b>
<b>Material restatement adjustments</b>	
Audit qualifications	-
Deferred tax impact on above restatement adjustments	-
<b>C. Total impact of adjustments</b>	<b>-</b>
<b>Opening balance as at April 1, 2015 as restated ( A+B+C)</b>	<b>2,153.64</b>

Modifications in the auditor's report and statements/comments included in the Annexure's to the Audit Report on the audited financial statements of the Company for the period ended September 30, 2018 and years ended March 31, 2018, March 31, 2017 and March 31, 2016 which do not require any corrective adjustments in the Restated Consolidated Financial Information are as follows:

Audit reservations / qualifications, which do not require any corrective adjustment in the consolidation financial information:

**(iv) (a) In respect of classification between specified bank notes and other denomination notes**

Extract of the details of Specified Bank Notes (SBN) or other denomination notes as defined in the MCA Notification No. GSR 300(E) dated March 31, 2017 held and transacted during the period from November 8, 2016 to December 30, 2016 from the audited financial statements for the year ended March 31, 2017:

Particulars	SBNs	Other Denomination Notes	Total
<b>Closing cash in hand as on November 8, 2016</b>	1.99	0.49	2.48
(+) Permitted receipts	-	4.50	4.50
(-) Permitted payments	0.08	3.23	3.31
(-) Amount deposited in banks	1.91	-	1.91
<b>Closing cash in hand as on December 30, 2016</b>	<b>-</b>	<b>1.76</b>	<b>1.76</b>

For the purpose of this note, the term Specified Bank Notes (SBN), shall have the same meaning provided in the notification of the Government of India, in the Ministry of Finance, Department of Economic Affairs number S.O. 3407(E), dated November 8, 2016.

**UNIPARTS INDIA LIMITED**

**Annexure VIII: Restated Consolidated Statement of Accounting Ratios**

(All amounts in millions of INR, unless stated otherwise)

Particulars	As At			
	As at September 30, 2018	As at March 31, 2018	As at March 31, 2017 Proforma Ind AS	As at March 31, 2016 Proforma Ind AS
A. Net worth	3,884.51	3,645.10	3,178.53	2,941.98
B. Profit attributable to the owners of the company	441.74	535.33	265.20	447.12
<b>Weighted average number of equity shares outstanding during the year (also refer note 29)</b>				
C. For basic earnings per share	44,106,558	44,106,558	44,106,558	44,106,558
D. For diluted earnings per share	45,133,758	45,133,758	45,133,758	45,133,758
E. Number of shares outstanding at the end of the year	45,133,758	45,133,758	45,133,758	45,133,758
F. Restated basic earnings per share (INR) (B/C)	10.02	12.14	6.01	10.14
G. Restated diluted earnings per share (INR) (B/D)	9.79	11.86	5.88	9.91
H. Return on net worth (%) (B/A)	11.37%	14.69%	8.34%	15.20%
I. Net assets value per share of INR 10 each (A/D)	86.07	80.76	70.42	65.18
J. EBITDA (INR)	783.24	1,005.08	679.28	902.88
K. Face value (INR)	10.00	10.00	10.00	10.00

**Notes:**

1. The ratio has been computed as below:

Basic earnings per share (INR) = 
$$\frac{\text{Net profit after tax attributable to owners of the Company, as restated}}{\text{Weighted average number of equity shares outstanding during the year}}$$

Diluted earnings per share (INR) = 
$$\frac{\text{Net profit after tax attributable to owners of the Company, as restated}}{\text{Weighted average number of potential equity shares outstanding during the year}}$$

Return on net worth (%) = 
$$\frac{\text{Net profit after tax attributable to the owners of the Company, as restated}}{\text{Net worth as restated as at year end}}$$

Net asset value per share (INR) = 
$$\frac{\text{Net worth, as restated}}{\text{Number of equity shares outstanding as at year end}}$$

EBITDA (INR) = Profit before tax (-) Finance costs (-) Depreciation and amortisation expense

2. Earning per shares (EPS) calculation is in accordance with the notified Indian Accounting Standard (Ind AS) 33 'Earnings per share' prescribed by the Companies (Indian Accounting Standards) Rules, 2015.

3. The amounts disclosed above are based on the Restated Consolidated Financial Information of the Company.

4. Net worth means the aggregate value of the paid up share capital of the Company and all reserves created out of profits and securities premium account as per Restated Consolidated Statement of Assets and Liabilities of the Company.

**UNIPARTS INDIA LIMITED****Annexure IX: Restated Consolidation Statement of Capitalisation**

(All amounts in millions of INR, unless stated otherwise)

PARTICULARS	Pre Issue (as at September 30, 2018)	Post- Issue*
<b>Borrowings:</b>		
Current borrowings	2,791.63	
Non-Current borrowings (A)	339.59	
<b>Total debt (B)</b>	<b>3,131.22</b>	
<b>Shareholders' fund (Net worth)</b>		
Share capital	446.20	
Other Equity	3,438.31	
<b>Total shareholders' fund (Net worth) (C)</b>	<b>3,884.51</b>	
<b>Non-Current borrowings/shareholders' fund (Net worth) ratio (A/C)</b>	0.09	
<b>Total borrowings/shareholders' fund (Net worth) ratio (B/C)</b>	0.81	

**Notes:**

1. Current borrowings and current maturities of long term borrowings are debts which are due for repayment within 12 months from September 30, 2018.

2. Non-Current borrowings is considered as borrowings other than short-term borrowings and includes current maturities of long term borrowings.

3. The amounts disclosed above are based on the Restated Consolidation Financial Information of the Company.

\* These amounts (as adjusted for issue) are not determinable at this stage pending the completion of the book building process and hence have not been furnished.

## OTHER FINANCIAL INFORMATION

1. The standalone financial statements of our Company as at and for the year ended March 31, 2018, March 31, 2017, and March 31, 2016 and the reports thereon dated May 29, 2018, June 15, 2017 and August 23, 2016, respectively (“**Standalone Financial Statements**”) are available at <https://unipartsgroup.com/investor-finance-annual.asp?links=inv1>. Our Company is providing a link to this website solely to comply with the requirements specified in the Securities and Exchange Board of India (Issue of Capital and Disclosure Requirement) Regulations, 2018. The Standalone Financial Statements do not constitute, (i) a part of this Draft Red Herring Prospectus; or (ii) a prospectus, a statement in lieu of a prospectus, an offering circular, an offering memorandum, an advertisement, an offer or a solicitation of any offer or an offer document to purchase or sell any securities under the Companies Act, 2013, the Securities and Exchange Board of India (Issue of Capital and Disclosure Requirement) Regulations, 2018, or any other applicable law in India or elsewhere in the world. The Standalone Financial Statements should not be considered as part of information that any investor should consider to subscribe for or purchase any securities of our Company or any of its subsidiaries, or any entity in which it or its shareholders have significant influence (collectively, the “**Group**”) and should not be relied upon or used as a basis for any investment decision. None of the Group or any of its advisors, nor any BRLMs or Selling Shareholders, nor any of their respective employees, directors, affiliates, agents or representatives accept any liability whatsoever for any loss, direct or indirect, arising from any information presented or contained in the Standalone Financial Statements, or the opinions expressed therein.
2. For details of accounting ratios, see “*Financial Statements - Annexure VIII: Restated Consolidated Statement of Accounting Ratios*” on page 234.

## CAPITALISATION STATEMENT

The following table sets forth our Company's capitalization as at September 30, 2018, on the basis of our Restated Financial Statements, and as adjusted for the Offer. This table should be read in conjunction with the sections titled "*Management's Discussion and Analysis of Financial Condition and Results of Operations*", "*Financial Statements*" and "*Risk Factors*" beginning on pages 241, 162 and 21, respectively.

(₹ in million)

Particulars	Pre-Offer as at September 30, 2018	As adjusted for the proposed Offer**
<b>Total borrowings</b>		
Short term borrowings*	2,791.63	-
Long term borrowings (including current maturity)*	339.59	-
<b>Total equity</b>		
Share capital*	446.20	
Reserves and surplus*	3,438.34	-
Money received against share warrants*	Nil	
<b>Total Capital</b>	3,884.54	-
Ratio: long term borrowings/ total equity	0.09	-

\* These terms shall carry the meaning as per Schedule III of the Companies Act, 2013 (as amended).

\*\* To be updated upon finalization of the Offer Price.



## FINANCIAL INDEBTEDNESS

Our Company and Subsidiaries avail loans in the ordinary course of business for meeting their working capital and business requirements. Our Company and our Promoters also provide guarantees in relation to the loans availed by our Subsidiaries as and when required. Our Company has obtained the necessary consents required under the relevant loan documentation for undertaking activities, such as change in our board of directors, change in our capital structure, change in our shareholding pattern and change in our constitution.

Pursuant to a resolution passed by our Shareholders dated November 27, 2018 our Board has been authorised to borrow any sum or sums of monies in excess of our Company's aggregate paid-up capital and free reserves, provided that the total amount which may be so borrowed and outstanding shall not exceed a sum of ₹ 5,000 million for our Company alone and ₹ 7,000 million for our Company and its Subsidiaries taken together.

The details of aggregate indebtedness of our Company and our Subsidiaries as on October 31, 2018 is provided below:

(in ₹ million)

Category of Borrowing	Sanctioned Amount (to the extent applicable)	Principal amount outstanding as on October 31, 2018
<b>Working Capital facilities</b>		
<b>Secured</b>		
Fund based	3,281.28	2,766.34
Non-fund based	0.40	-
<b>Total (A)</b>	<b>3,281.68</b>	<b>2,766.34</b>
<b>Unsecured</b>		
Fund based	40.00	33.42
Non-fund based	-	-
<b>Total (B)</b>	<b>40.00</b>	<b>33.42</b>
<b>Total Working Capital facilities (A+B)</b>	<b>3,321.68</b>	<b>2,799.75</b>
<b>Term Loan Facilities</b>		
<b>Secured (C1)</b>	621.18	483.37
<b>Unsecured (C2)</b>	-	-
<b>Total term loan facilities (C=C1+C2)</b>	<b>621.18</b>	<b>483.37</b>
<b>Total borrowings (A+B+C)</b>	<b>3,942.86</b>	<b>3,283.12</b>

\* As certified by Rakesh Banwari & Co., Chartered Accountants, by way of their certificate dated November 30, 2018.

### Principal terms of the borrowings availed by us:

The details provided below are indicative and there may be additional terms, conditions and requirements under the various borrowing arrangements entered into by us.

1. **Interest:** All our borrowings have a floating rate of interest.
2. **Prepayment Penalty:** Some of the facilities availed by us carry a pre-payment penalty of up to 2.00% on the pre-paid amount or on the outstanding amount, as applicable, or such other penalty as may be levied at the discretion of the lenders.
3. **Penal Interest:** The terms of the facilities availed by us prescribe penalties for delayed payment or default in the repayment obligations, delay in creation of the stipulated security or certain other specified obligations, which typically ranges from 2.00% to 4.00% over and above the applicable interest rate.
4. **Validity/Tenor:** The tenor of the term loan availed by us is for 60 months and tenor of working capital facilities ranges from 90 days to one year, with an option of renewal.
5. **Security:** In terms of our borrowings where security needs to be created, such security typically includes:
  - (a) Charge by way of hypothecation on movable fixed assets, book debts and all other current assets, both present and future;
  - (b) Charge by way of mortgage on both present and future movable fixed assets and immovable assets, owned or leased;
  - (c) Pledge of units of certain mutual funds held by the Promoters;
  - (d) Personal guarantees from our Promoters: Our Promoters have provided guarantees to Citibank, N.A, Kotak Mahindra Bank Limited, IndusInd Bank Limited and DBS Bank Limited aggregating to ₹ 1,818.80 million with respect to the borrowings availed by us. These guarantees are valid for the duration of such borrowings. In case of default, our Promoters shall be liable to pay all monies advanced by the respective

lenders, interest, cost and any other money due thereon. There was no consideration received by them in providing such guarantees and no security has been provided by them against such guarantees.

6. **Repayment:** The term loans availed by our Company are typically repayable in monthly instalments and the working capital facilities are typically repayable on demand.
7. **Key Covenants:** Several of our financing arrangements entail various restrictive covenants and conditions restricting certain corporate actions, and we are required to take the prior approval of the respective lender before carrying out such actions, including for:
  - (a) any change in the capital structure;
  - (b) undertaking or implementing a new scheme of expansion or an allied line of business or manufacture;
  - (c) any change in the management setup;
  - (d) permitting any transfer of controlling interest;
  - (e) paying commission to our Promoters, Directors, managers or other persons for furnishing guarantees, counter guarantees or indemnities or for undertaking any liability in connection with any financial obligation obtained by our Company;
  - (f) any change in the accounting methods or policies followed;
  - (g) any alteration in the Memorandum of Association or Articles of Association;
  - (h) cross defaults or cross accelerations;
  - (i) any withdrawal of the capital invested in the business by the proprietor/ Directors of our Company during the currency of the loan facility;
  - (j) entering into borrowing arrangements either secured or unsecured with any other bank, financial institution, company or person;
  - (k) grant loans to Promoters or associates or any other company; and
  - (l) undertaking any guarantee obligations on behalf of any other company (including group companies).

Please note that the abovementioned list is indicative and there may be additional restrictive covenants and conditions where we may be required to take prior approval of respective lender under the various borrowing arrangements entered into by us.

8. **Events of Default:** In terms of borrowing arrangements for the facilities availed by us, the occurrence of any of the following, among others, constitute an event of default:
  - (a) change in ownership, management, and/or control without prior written consent of the lender;
  - (b) all or substantially all of the undertakings, assets or properties or the interest therein being seized, nationalized, expropriated or compulsorily acquired by the authority of the Government;
  - (c) failure to create, perfect or maintain security in the opinion of the lender as provided for the secured borrowings;
  - (d) upon any distress, attachment, execution, receipt of a garnishee order or other process or enforcement of any of the securities;
  - (e) non-payment or defaults of any amounts including the principal, interest or other charges;
  - (f) breach of any representation, warranty, declaration, covenant or undertaking furnished by us under the loan documentation; and
  - (g) upon happening of any circumstances or event which would or is likely to prejudicially or adversely affect in any manner the capacity to repay the loan.

Please note that the abovementioned list is indicative and there may be additional terms that may amount to an event of default under the various borrowing arrangements entered into by us.

9. ***Consequences of occurrence of events of default:*** In terms of our borrowing arrangements for the facilities availed by us, upon the occurrence of events of default, our lenders may:
- (a) suspend or cancel any of their obligation for any advance under the loan documentation;
  - (b) have the right to recover the entire dues of the loan under the respective facilities;
  - (c) substitute or restructure the management set up of our Company,
  - (d) take charge, seize, recover, receive, appoint receivers or remove and take possession of all or any part of the security created;
  - (e) charge penal interest on the outstanding amounts till the time event of default is rectified;
  - (f) transfer any of the secured asset in favour of the respective lender or such other person by way of lease, leave and licence, sale or otherwise;
  - (g) appoint nominee directors on our Board;
  - (h) declare all amount outstanding to become payable immediately under the respective facilities; and
  - (i) convert the entire facility and/or the unpaid interest thereon and/or other monies payable into fully paid-up equity shares.

## MANAGEMENT'S DISCUSSION AND ANALYSIS OF FINANCIAL CONDITION AND RESULTS OF OPERATIONS

*The following discussion and analysis of our financial condition and results of operations are based on, and should be read in conjunction with the Restated Financial Statements, the notes and significant accounting policies thereto and the reports thereon in "Financial Statements" beginning on page 162, which have been prepared in accordance with IND AS, the Companies Act and the SEBI ICDR Regulations.*

*Our consolidated financial statements, as included in this Draft Red Herring Prospectus, for the six months ended September 30, 2018, were prepared in accordance with Ind AS and restated in accordance with the requirements of SEBI ICDR Regulations, and for the financial years ended March 31, 2018, 2017 and 2016 were prepared in accordance with Indian GAAP, which have been translated into figures as per Ind AS to align accounting policies, exemptions and disclosures as adopted by our Company on its first-time adoption of Ind AS on the transition date and are restated in accordance with requirements of SEBI ICDR Regulations. Ind AS differs in certain material respects from IFRS and U.S. GAAP. We have not attempted to quantify the impact of IFRS or U.S. GAAP on the financial information included in this Draft Red Herring Prospectus, nor do we provide a reconciliation of our financial statements to those under U.S. GAAP or IFRS. Accordingly, the degree to which the financial information included in this Draft Red Herring Prospectus will provide meaningful information depends on the reader's level of familiarity with the Companies Act, IND AS and the SEBI ICDR Regulations. Any reliance on the financial disclosure in this Draft Red Herring Prospectus, by persons not familiar with Indian accounting practices, should accordingly be limited.*

*Our fiscal year ends on March 31 of each year. Accordingly, unless otherwise stated, all references to a particular Fiscal are to the 12-month period ended March 31 of that year.*

*This discussion also contains certain forward-looking statements and reflects our management's current views with respect to future events and our financial performance. Actual results may differ materially from those anticipated in these forward-looking statements. By their nature, certain market risk disclosures are only estimates and could be materially different from what actually occurs in the future. As a result, actual future gains or losses could materially differ from those that have been estimated. Given these uncertainties, prospective investors should not place undue reliance on such forward-looking statements. Factors that could cause or contribute to such differences include, but are not limited to, those discussed in the sections titled "Risk Factors", "Forward Looking Statements" and "Our Business" on pages 21, 16 and 113, respectively.*

### **Significant factors affecting our results of operations and financial condition**

We believe that the following factors have significantly affected our results of operations and financial condition during the periods under review and may continue to affect our results of operations and financial condition in the future.

#### ***Market conditions affecting the OHV industry***

The sales of our products are directly related to the production and sales of OHVs by our major customers. OHV production and sales may be affected by general economic or industry conditions, including seasonal trends in the agriculture sector and cyclical or countercyclical effects in the CFM sector, recessionary trends in the global and domestic economies, volatility in new housing construction, as well as evolving regulatory requirements, government initiatives, trade agreements and other factors including volatile fuel prices, rising employee expenses and challenges in maintaining amicable labor relations. The cyclical nature of the agriculture and CFM industries, both globally and in regions in which we operate, means that our revenues across periods could fluctuate significantly.

It is difficult to forecast the potential for labor disputes or the success or sustainability of any strategies undertaken by any of our major customers in response to the current economic or industry environment. Unfavorable industry conditions can also result in an increase in commercial disputes and other risks of supply disruption. A sustained decline in the demand for products produced by our OEM customers could prompt them to cut their production volumes, directly affecting the demand from OEMs for our products and consequently adversely impacting our revenues.

#### ***Global service delivery model***

Local Deliveries contributed to 35.08%, 36.54%, 38.27% and 38.11% of our revenue from operations during the six months ended September 30, 2018 and in Fiscals 2018, 2017 and 2016, respectively, while Direct Exports contributed to 22.35%, 24.90%, 26.49% and 27.26%, respectively, and Warehouse Sales contributed to 38.45%, 34.67%, 31.66% and 31.30%, respectively, of our revenue from operations in the same periods.

We have set up our global service delivery model in a scalable manner, optimized to provide premium-priced Local Deliveries manufactured onshore in smaller lots and with shorter lead times, as well as cost-competitive offshore deliveries from India with longer lead times and greater inventory cycles. As part of our growth strategy, we intend to focus on increasing our Warehouse Sales, on which we enjoy better margins. Towards implementation of this strategy, we are increasingly serving some of our largest customers in the OEM as well as aftermarket segments through the Warehouse Sales

model. Accordingly, we expect that the proportion of our Warehouse Sales may increase going forward, as compared to Direct Exports and Local Deliveries, which we believe may have a favorable impact on our margins, going forward.

However, an increased proportion of Warehousing Sales may lead to increased inventory maintained at our warehouses, leading to a higher overall working capital requirement. In addition, if a significant customer defaults in payment on any order to which we have devoted significant resources and built significant unsold inventory, it may affect our profitability and liquidity and decrease capital resources available to us for other uses.

For more information, see “*Our Business – Global service delivery model*” on page 124.

#### ***Customer concentration, purchasing patterns, terms of supply arrangements and pricing of our products***

A substantial majority of our income from operations is from sales to OEMs. These constituted 82.46%, 85.03%, 84.48% and 84.00% of our revenue from operations during the six months ended September 30, 2018 and in Fiscals 2018, 2017 and 2016, within which we depend on a limited number of customers for a significant portion of our revenues. Revenue from our top 10 customers across product segments constituted 77.01%, 77.01%, 77.72% and 79.34%, of our revenue from operations for the six months ended September 30, 2018 and Fiscals 2018, 2017 and 2016, respectively. The demand for our products from such major customers has a significant impact on our results of operations and financial condition, and our sales are particularly affected by the inventory and production levels of our key OEM customers. The volume and timing of sales to our customers may vary due to variation in demand for our customers’ products, our customers’ attempts to manage their inventory, design changes, changes in their product mix, manufacturing strategy and growth strategy, and macroeconomic factors affecting the economy in general and our customers in particular. We may experience reduction in cash flows and liquidity if we lose one or more of our major customers, or if the amount of business from them is reduced for any reason, or if we are unable to forecast the level of customer demand for our products accurately, schedule our raw material purchases and production and manage our inventory.

We have entered into long-term customer agreements with certain of our key OEM customers in accordance with which such customers provide us with forecasts of business volumes, which enable us to predict our income for a portion of our business; however, the actual orders are placed by way of on-going purchase orders. Therefore, actual production volumes may vary significantly from these forecasts. There may be instances where customers modify their product specifications and/or timing of procurement with little advance notice, which may require us to increase or decrease production and inventories at short notice and bear additional costs. Further, timing mismatches between our customer contracts and our supplier contracts may impact availability of raw materials required by us, or may lead us to incur additional costs.

Our supply arrangements with our key OEM customers typically provide for periodic price review of our products (generally bi-annual, although annual or quarterly in certain cases). In addition, under some of our long term agreements with our key OEM customers, we may be required to provide an annual cost reduction in relation to our products. Our continued ability to undertake value engineering and provide cost reductions to our customers is linked to our ability to maintain or improve our margins. Any significant cost reductions that we are not able to compensate for through value engineering and process innovation may, therefore, reduce our profitability.

Our contracts and supply arrangements with key OEM customers also contain certain standards and performance obligations and our failure to meet such specification could result in reduction of business, termination of contracts or additional costs and penalties.

#### ***Input and employee costs***

Our cost of raw material and components consumed, including change in inventory, represented 30.24%, 33.34%, 34.38% and 35.46% of our revenue from operations, respectively, for the six months ended September 30, 2018 and for Fiscals 2018, 2017 and 2016, respectively. Our results of operations are significantly impacted by the availability and cost of raw materials, in particular steel. Steel accounted for 68.77%, 69.85%, 69.08% and 70.36% of our raw material purchases in value terms for the six months ended September 30, 2018 and in Fiscals 2018, 2017 and 2016, respectively. The steel sourced in India accounted for 47.42%, 48.04%, 46.28% and 43.13% and our expenditure on steel sourced in U.S accounted for 21.34%, 21.81%, 22.79% and 27.23% of our raw material purchases in value terms for the six months ended September 30, 2018 and in Fiscals 2018, 2017 and 2016, respectively. For our Indian manufacturing operations, we source steel directly from Indian steel mills. We have also developed a supply chain for sourcing specific forms of steel, such as seamless tubes and steel bars, from China, for our manufacturing facilities in India. Steel used for products manufactured in our facility at Eldridge, Iowa, is primarily sourced in the U.S. from distributors.

While we are not significantly dependent on any single raw material supplier, raw material supply and pricing can be volatile due to a number of factors beyond our control. Commodity prices are influenced by, among other factors, changes in global economic conditions, industry cycles, demand-supply dynamics, attempts by producers to capture market share and speculation in the market, as well as import duties, tariffs and currency exchange rates. The changes in raw material costs are generally passed through to our OEM customers under long term agreements. Nonetheless, because such price adjustments based on cost changes only occur at periodic intervals, there is generally a time lag between changes in our raw material costs

and any adjustments to prices of our products, which, if such raw material costs increase significantly during this period, can have a negative impact on our profitability. We also seek to increase our margins by improving our procurement costs for steel in India and obtaining better credit terms from our suppliers and better financing terms under our working capital facilities.

Employee benefits expense comprises our second largest expense after raw material costs. For the six months ended September 30, 2018 and in Fiscals 2018, 2017 and 2016, our employee benefits expense aggregated to ₹ 1,053.55 million, ₹ 1,769.58 million, ₹ 1,581.81 million and ₹ 1,595.76 million, respectively, and, as a percentage of our revenue from operations, were 20.43%, 20.91%, 22.50% and 20.47%, respectively in those periods. We are both backward and forward integrated in terms of our operations which as a business model inherently has higher manpower cost but at the same time helps in managing material cost, product quality and customer service levels. However, we believe that we have sufficient human resources to sustain our current operations and planned growth, particularly at the management level. Our employee benefit expenses are affected by statutorily prescribed minimum wage as well as wage payments following retrenchment, besides the increase in headcount due to increase in volumes. As a material portion of our overall manpower is located in India, rising wages in India will have a material impact on our net income. In recent times, labour related costs have been rising in India. For instance, in Fiscal 2018, our costs were adversely affected due to higher than usual increase in minimum wages across states in India in February 2017, which in turn affected our costs. While our employee benefit expenses may increase in absolute terms, we expect to improve our operational efficiencies, which we believe may result in a reduction in our employee benefits expense as a percentage of our revenue from operations.

### ***Macroeconomic conditions***

Our sales volumes, profitability and liquidity are closely tied to the level of agricultural and CFM activity worldwide, as our customers and end-users primarily operate in the agriculture and CFM sectors and are, therefore, affected by factors that affect the agriculture and CFM sectors, including the levels of investment and production in these specific sectors of the global and domestic economies. In particular, the agricultural sector is inherently seasonal and is further impacted by factors including agricultural commodity prices, costs of fertilizers and adverse weather conditions. There may also be a number of secondary effects of an economic downturn, such as the insolvency of suppliers or customers, delays in deliveries by suppliers, payment delays and/or stagnant demand by customers. Cuts in federal or central, state and local government investment as well as consequent impairment in infrastructural facilities and growth can also drag down global and national growth rates.

A significant majority of the end users of our products are located and operating in North and South America, Europe, Japan and India and some of them were adversely impacted by the recession in some of these economies, disruption in banking and financial systems, economic weakness, unfavorable government policies, rising inflation, lowering spending power, customer confidence and political uncertainty.

While the global economy has recovered to some extent, we are unable to predict with any degree of certainty the pace or sustainability of economic recovery, the volumes of federal or central, state and local government investment, or the effects of regulatory intervention.

Further, our business plans envisage enhancing our operations in line with our customers' growth in key markets, including India, Europe and Japan. We expect to continue to incur substantial expenditure in connection with setting up new facilities, which would require us to successfully attract additional business from our existing and new customers. While we consult with our customers prior to expanding in current markets or setting up operations in new markets, our customers may not give us sufficient commitments to purchase our products in these markets. Accordingly, our successful expansion in any market is subject to business, economic and competitive uncertainties and contingencies, many of which are beyond our control.

### ***Foreign currency fluctuations***

We are exposed to foreign exchange rate fluctuations in respect of (i) our foreign currency denominated borrowings (mainly in US\$), (ii) currency mismatches between our revenues and expenses, and (iii) currency translation losses for the purpose of preparing our consolidated financial statements (which are presented in Indian Rupees), on account of our global operations.

Our revenues, operating expenses and finance costs are influenced by the currencies of those countries where we manufacture and/or sell our products (for example, the United States, Europe and Japan). The exchange rate between the Indian Rupee and these currencies, primarily the US\$, has fluctuated in the past and our results of operations have been impacted by such fluctuations in the past and may be impacted by such fluctuations in the future. For example, during times of strengthening of the Indian Rupee, we expect that our overseas sales and revenues will generally be negatively impacted as foreign currency received will be translated into fewer Indian Rupees. However, the converse positive effect of depreciation in the Indian Rupee may not be sustained or may not show an appreciable impact in our results of operations in any given financial period, due to other variables impacting our business and results of operations during the same period. Moreover, as a majority of our long-term (non-current) and working capital borrowings are US\$ denominated, we expect that our cost of borrowing as well as our cost of raw materials and components incurred by our foreign Subsidiaries may rise during a sustained depreciation of the Indian Rupee against the US\$.

We may, therefore, suffer losses on account of foreign currency fluctuations for our inventory in our international warehouses, since the prices that our customers pay for our products are only subject to revision for foreign currency fluctuations on a periodic basis and in certain cases outside a specified range and we may not be able to pass on all losses on account of foreign currency fluctuations to our customers. Moreover, we may be required to reconfigure our loan portfolio from time to time, so as to effectively manage our finance charges.

While we seek to hedge our foreign currency risk by entering into forward exchange contracts or matching our revenue and expenses currency as much as possible, any action that we may take or any amounts we spend or invest in order to hedge the risks on account of fluctuations in currencies may not adequately hedge against any losses we incur due to such fluctuations. Our exchange differences (net) for the six months ended September 30, 2018 and for fiscals 2018, 2017 and 2016 amounted to loss of 38.81 million, gain of ₹ 131.93 million, gain of ₹ 78.67 million and loss of ₹17.59 million, respectively. As on September 30, 2018, our total unhedged foreign currency receivables amounted to ₹ 28.18 million, our total unhedged foreign currency loans amounted to ₹ 15.48 million, while our total unhedged foreign currency payables amounted to ₹ 4.67 million and the total value of our outstanding forward exchange contracts amounted to ₹ 1,058.26 million.

During the consolidation of our foreign Subsidiaries' financials with the Company's financials, differences arising out of (i) conversion of material consumption value denominated in foreign currency at the average exchange rate for the period to arrive at the material consumption value in Rupees (reporting currency) for the period; and (ii) conversion of opening inventory at the period opening foreign exchange rate, closing inventory at period closing foreign exchange rate, purchase for the period at average exchange rate for the period to arrive at the material consumption value in Rupees for the period, results in an overall gain or loss (depending upon the foreign currency exchange rates movement during the period), which is attributable to the movement in foreign currency exchange rates over the reporting period.

### **First Time Adoption of IND AS**

Our Restated Financial Statements, as included in this Draft Red Herring Prospectus, in respect of Fiscals ended March 31, 2017 and 2016 were prepared in accordance with Indian GAAP, which have been translated into figures as per Ind AS, on a proforma basis (the "**Proforma Ind AS Restated Financial Information**") in accordance with the requirements of Circular SEBI/HO/CFD/DIL/CIR/P/2016/47 dated March 31, 2016 issued by the SEBI ("**SEBI Circular**") and Guidance note on reports on company prospectus issued by ICAI. For the purpose of the Proforma Ind AS Restated Financial Information, we have followed the same accounting policies and accounting policy choices (both mandatory exceptions and optional exemptions available as per Ind AS-101) as initially adopted on transition date by way of suitable restatement adjustments (both re-measurement and reclassification in the Proforma Ind AS Restated Financial Information).

Further, effective from April 1, 2018, we adopted Ind AS 115 'Revenue from Contracts with Customers'. The standard is applied retrospectively with the cumulative effect of initially applying this standard as an adjustment to the opening balance of retained earnings at the date of initial application. The adoption of Ind AS 115 did not have any impact on the overall revenue and/or opening balance of retained earnings.

### **Basis of Consolidation**

The Restated Financial Statements comprise the restated consolidated financial statements of our Company and its Subsidiaries as at and for the six months ended September 30, 2018, and as at and for the Fiscals ended March 31 2018, 2017 and 2016. Subsidiary companies are the entities over which the Company has control. Control is achieved when our Company is exposed to, or has rights to, variable returns from its involvement with the entity and has the ability to affect those returns through its power to direct the relevant activities of the entity.

Consolidated financial statements are prepared using uniform accounting policies for like transactions and other events in similar circumstances. If any of the consolidated entities uses accounting policies other than those adopted in the consolidated financial statements for like transactions and events in similar circumstances, appropriate adjustments are made to such entity's financial statements in preparing the consolidated financial statements to ensure conformity with our Company's accounting policies. The financial statements of all consolidated entities used for the purpose of consolidation are drawn up to same reporting date as that of our Company, i.e. Fiscal ended on 31 March.

### **Results of Operations**

The following table sets out selected data for the six months ended September 30, 2018 and for Fiscals 2018, 2017 and 2016, together with the percentage each line item represents of our total income for the periods presented.

Particulars	Six months ended September 30, 2018		Fiscal					
			2018		2017		2016	
	(₹ in million)	Percentage of Total Income	(₹ in million)	Percentage of Total Income (%)	(₹ in million)	Percentage of Total Income	(₹ in million)	Percentage of Total Income
<b>Income</b>								
Revenue from operations	5,157.11	99.92%	8,461.86	99.89%	7,031.47	99.71%	7,795.20	99.74%
Other income	3.89	0.08%	9.30	0.11%	20.72	0.29%	20.23	0.26%
<b>Total income</b>	<b>5,161.00</b>	<b>100.00%</b>	<b>8,471.16</b>	<b>100.00%</b>	<b>7,052.19</b>	<b>100.00%</b>	<b>7,815.43</b>	<b>100.00%</b>
<b>Expenses</b>								
Cost of raw materials and components consumed	2,176.41	42.17%	3,369.36	39.77%	2,390.71	33.90%	2,817.01	36.04%
Changes in inventory	(616.83)	(11.95)%	(548.01)	(6.47)%	27.06	0.38%	(52.59)	(0.67)%
Excise Duty on Sale of Goods	-	-	44.04	0.52%	106.47	1.51%	106.35	1.36%
Employee benefit expenses	1,053.55	20.41%	1,769.58	20.89%	1,581.81	22.43%	1,595.76	20.42%
Finance costs	70.22	1.36%	90.32	1.07%	86.55	1.23%	100.48	1.29%
Depreciation and amortization expense	111.06	2.15%	208.53	2.46%	197.66	2.80%	184.89	2.37%
Other expenses	1,764.63	34.19%	2,831.10	33.42%	2,266.87	32.14%	2,446.03	31.30%
<b>Total expenses</b>	<b>4,559.04</b>	<b>88.34%</b>	<b>7,764.92</b>	<b>91.66%</b>	<b>6,657.12</b>	<b>94.40%</b>	<b>7,197.93</b>	<b>92.10%</b>
<b>Profit before tax</b>	<b>601.96</b>	<b>11.66%</b>	<b>706.24</b>	<b>8.34%</b>	<b>395.07</b>	<b>5.60%</b>	<b>617.50</b>	<b>7.90%</b>
Less: Tax expense								
-For current year	121.05	2.35%	195.15	2.30%	100.09	1.42%	137.13	1.75%
MAT credit	13.40	0.26%	13.63	0.16%	20.64	0.29%	33.55	0.43%
Deferred tax (credit)/charge	25.77	0.50%	(37.88)	(0.45)%	9.14	0.13%	(0.29)	0.00%
<b>Total tax expense</b>	<b>160.22</b>	<b>3.10%</b>	<b>170.90</b>	<b>2.02%</b>	<b>129.87</b>	<b>1.84%</b>	<b>170.39</b>	<b>2.18%</b>
<b>Profit for the year</b>	<b>441.74</b>	<b>8.56%</b>	<b>535.33</b>	<b>6.32%</b>	<b>265.20</b>	<b>3.76%</b>	<b>447.12</b>	<b>5.72%</b>

The following table shows our EBITDA for the periods indicated:

Particulars	Six months ended September 30, 2018		Fiscal 2018		Fiscal 2017		Fiscal 2016	
	(₹ in million)	Percentage of total income (%)	(₹ in million)	Percentage of total income (%)	(₹ in million)	Percentage of total income (%)	(₹ in million)	Percentage of total income (%)
<b>EBITDA</b>	<b>783.24</b>	<b>15.18%</b>	<b>1,005.08</b>	<b>11.86%</b>	<b>679.28</b>	<b>9.63%</b>	<b>902.88</b>	<b>11.55%</b>

Consequent to introduction of Goods and Service Tax (“GST”) with effect from July 1, 2017, central excise and value added tax have been subsumed into GST. In accordance with Ind AS 18, GST is not considered a part of revenue unlike excise duties which used to be included in revenue prior to July 1, 2017. Accordingly, the amounts for Fiscal 2018 are not directly comparable with the previous Fiscals.

#### **Six months ended September 30, 2018**

##### *Income*

Our total income for the six months ended September 30, 2018 was ₹ 5,161.00 million, primarily comprising of (i) revenue from operations (comprising revenue from sale of products and other operating revenues, i.e. export incentives); and (ii) other income (comprising interest income and miscellaneous receipts).

Our revenue from operations for the six months ended September 30, 2018 was ₹ 5,157.11 million.

For the six months ended September 30, 2018, our 3PL vertical accounted for 47.48%, our PMP vertical accounted for 46.79%, our hydraulic cylinders vertical accounted for 0.26% and our PTO vertical accounted for 0.83% of our revenue from operations. Local Deliveries contributed to 35.08%, Direct Exports contributed to 22.35% and Warehouse Sales contributed to 38.45% of our revenue from operations for the six months ended September 30, 2018. International Sales accounted for 82.44% of our revenue from operations during this period.

Sale of finished goods: Our sale of finished goods [net of returns, rebate etc.] was ₹ 4,944.68 million for the period ended September 30, 2018, which constituted 95.88% of our revenue from operations.

Sale of scrap: Our sale of scrap was ₹ 118.15 million for the period ended September 30, 2018.



## *Expenses*

For the six months ended September 30, 2018, our total expenses were ₹ 4,559.04 million, which, as a percentage of our total income amounted to 88.34%.

Cost of raw materials and components consumed and changes in inventory: For the six months ended September 30, 2018, our cost of raw materials and components consumed (which primarily consists of steel), including change in inventory, amounted to ₹ 1,559.58 million. As a percentage of our total income, cost of raw materials and components consumed (net of changes in inventory) was 30.22% for six months period ended September 30, 2018.

Employee benefit expenses: For the six months ended September 30, 2018, our employee benefit expenses, which primarily consisted of salaries and wages, contribution to provident and other funds and staff welfare expenses, amounted to ₹ 1,053.55 million. As a percentage of our total income for the six months ended September 30, 2018, our employee benefit expenses were 20.41%.

Depreciation and amortization expense: Our depreciation and amortization expense amounted to ₹ 111.06 million for the six months ended September 30, 2018, primarily in relation to plant and machinery, building, computers, land, intangible assets and other assets comprising furniture and fittings, vehicles and leasehold improvements.

Finance costs: Our finance costs, which primarily consist of interest, in addition to bill discounting charges and bank charges, amounted to ₹ 70.22 million during the six months ended September 30, 2018. As a percentage of our total income, finance costs were 1.36% for the six months ended September 30, 2018.

Other expenses: For the six months ended September 30, 2018, our other expenses, which primarily consisted of stores, spares and tools consumed, sub-contracting expenses, power, fuel and water, cartage, freight and forwarding, air freight, rent and repairs and maintenance, amounted to ₹ 1,764.63 million. As a percentage of our total income, other expenses constituted 34.19% for the six months ended September 30, 2018.

## *EBITDA*

For the six months ended September 30, 2018, our EBITDA was ₹ 783.24 million, constituting 15.18% of our total income.

## *Profit before tax*

As a result of the foregoing, our profit before tax for the six months ended September 30, 2018 was ₹ 601.96 million.

## *Total tax expense*

Our total tax expense for the six months ended September 30, 2018 was ₹ 160.22 million, comprising tax expense for the current year of ₹ 121.05 million, MAT credit of ₹ 13.40 million and deferred tax charge of ₹ 25.77 million

## *Profit for the period/ year*

As a result of the foregoing, our profit for the six months ended September 30, 2018 was ₹ 441.74 million, which, as a percentage of our total income, constituted 8.56%.

## ***Fiscal 2018 compared with Fiscal 2017***

### *Income*

Our total income comprises (i) revenue from operations (comprising revenue from sale of products, sale of services and other operating revenues, i.e. export incentives); and (ii) other income (comprising interest income, profit on sale of investment, profit on sale and lease back, lease receipts and miscellaneous receipts). Our total income in Fiscals 2018 and 2017 was ₹ 8,471.16 million and ₹ 7,052.19 million, respectively.

Consequent to introduction of GST with effect from July 1, 2017, central excise and value added tax have been subsumed into GST. In accordance with Ind AS 18, GST is not considered a part of revenue unlike excise duties which used to be included in revenue in period before 1 July 2017. Accordingly, the amounts for Fiscal 2018 are not directly comparable with the previous Fiscals.

Our revenue from operations increased by 20.34% to ₹ 8,461.86 million in Fiscal 2018 from ₹ 7,031.47 million in Fiscal 2017, primarily led by an increase in sale of finished goods [net of returns, rebate, etc.] due to an increase in volume of sales of our products as a result of our growth strategy as well as improved industry conditions in the global agricultural and construction equipment industries.

Our 3PL vertical accounted for 48.66% and 48.61%; our PMP vertical accounted for 44.91% and 44.20%; our PTO vertical accounted for 1.17% and 1.18% and our hydraulic cylinders vertical accounted for 0.30% and 0.27% of our revenue from operations in Fiscals 2018 and 2017, respectively. Further, our International Sales accounted for 81.99% and 81.38% of our revenue from operations in Fiscals 2018 and 2017, respectively. Local Deliveries contributed to 36.54% and 38.27% of our revenue from operations in Fiscals 2018 and 2017, respectively, while Direct Exports contributed to 24.90% and 26.49%, respectively, and Warehouse Sales contributed to 34.66% and 31.66%, respectively, of our revenue from operations during the same periods.

Sale of finished goods: Our sale of finished goods [net of returns, rebate etc.] increased to ₹ 8,131.96 million in Fiscal 2018 from ₹ 6,779.69 million in Fiscal 2017.

Sale of scrap: Our sale of scrap increased to ₹ 173.49 million in Fiscal 2018 from ₹ 129.60 million in Fiscal 2017.

#### *Expenses*

Our total expenses increased by 16.64% to ₹ 7,764.92 million in Fiscal 2018 from ₹ 6,657.12 million in Fiscal 2017. As a percentage of our total income, our total expenses decreased to 91.66% in Fiscal 2018 from 94.40% in Fiscal 2017.

Cost of raw materials and components consumed and changes in inventory: Our cost of raw materials and components consumed (which primarily consists of steel), including change in inventory, increased by 16.69% to ₹ 2,821.35 million in Fiscal 2018 from ₹ 2,417.77 in Fiscal 2017. This increase was on account of increase in overall production volumes as well as an increase in prices of steel during Fiscal 2018.

As a percentage of our total income, cost of raw materials and components consumed (net of changes in inventory) decreased to 33.31% in Fiscal 2018 from 34.28% in Fiscal 2017, primarily as a result of increase in Warehouse Sales (on which we earn higher margins) as well as operating and purchasing efficiencies.

Excise duty on sale of goods: Excise duty on sale of goods decreased by 58.64% to ₹ 44.04 million in Fiscal 2018 from ₹ 106.47 million in Fiscal 2017 on account of introduction of GST with effect from July 1, 2017.

Employee benefit expenses: Our employee benefit expenses, which primarily consist of salaries and wages, contribution to provident and other funds, expense on employee stock option scheme and staff welfare expenses, increased by 11.87% to ₹ 1,769.58 million in Fiscal 2018 from ₹ 1,581.81 million in Fiscal 2017, primarily due to an increase in the number of personnel engaged by us to support our increased volumes and an increase in the minimum wages in India. As a percentage of our total income, employee benefit expenses decreased to 20.89% in Fiscal 2018 from 22.43% in Fiscal 2017.

#### Depreciation and amortization expense

Our depreciation and amortization expense increased by 5.50% to ₹ 208.53 million in Fiscal 2018 from ₹ 197.66 million in Fiscal 2017, as a result of additional capital expenditure. We invested ₹ 206.82 million in plant and machinery, ₹ 12.96 million in building and balance investment was made in other assets, including IT infrastructure.

#### Finance costs

Our finance costs, which primarily consist of interest, in addition to bill discounting charges and bank charges, increased by 4.36% to ₹ 90.32 million in Fiscal 2018 from ₹ 86.55 million in Fiscal 2017, as a result of an increase in working capital borrowing requirements due to increase in production volumes and funding capital expenditure. As a percentage of our total income, finance costs decreased to 1.07% in Fiscal 2018 from 1.23% in Fiscal 2017.

Other expenses: Our other expenses, which primarily consist of stores, spares and tools consumed, sub-contracting expenses, power, fuel and water, cartage, freight and forwarding, air freight, rent and repairs and maintenance, increased to ₹ 2,831.10 million in Fiscal 2018 from ₹ 2,266.87 million in Fiscal 2017, primarily as a result of (i) increases in sub-contracting expenses from ₹ 644.50 million in Fiscal 2017 to ₹ 844.81 million in Fiscal 2018 due to the capacity constraints across all our units in India and in stores, spares and tools consumed from ₹ 466.46 million in Fiscal 2017 to ₹ 584.47 million in Fiscal 2018 due to growth in production volumes; and (ii) increase in air freight charges from ₹ 58.29 million in Fiscal 2017 to ₹ 205.15 million in Fiscal 2018, on account of incurring additional premium freight to meet the customer's delivery timelines. As a percentage of our total income, other expenses increased to 33.42% in Fiscal 2018 from 32.14% in Fiscal 2017.

#### *EBITDA*

As a result of the foregoing, our EBITDA increased by 47.96% to ₹ 1,005.08 million in Fiscal 2018 from ₹ 679.28 million in Fiscal 2017. EBITDA, as a percentage of our total income increased to 11.86% in Fiscal 2018 from 9.63% in Fiscal 2017.

#### *Profit before tax*

Our profit before tax increased by 78.76% to ₹ 706.24 million in Fiscal 2018 from ₹ 395.07 million in Fiscal 2017, largely due to the factors discussed above.

#### *Total tax expense*

Our total tax expense increased by 31.59% to ₹ 170.90 million in Fiscal 2018 from ₹ 129.87 million in Fiscal 2017, largely as a result of increase in profit in Fiscal 2018.

#### *Profit for the period/ year*

As a result of the foregoing, our profit for the year increased by 101.86% to ₹ 535.33 million in Fiscal 2018 from ₹ 265.20 million in Fiscal 2017. Our profit for the year, as a percentage of our total income, increased to 6.32% in Fiscal 2018 from 3.76% in Fiscal 2017.

### ***Fiscal 2017 compared with Fiscal 2016***

#### *Income*

Our total income comprises (i) revenue from operations (comprising revenue from sale of products, sale of services and other operating revenues, i.e. export incentives); and (ii) other income (comprising interest income, profit on sale of investment, profit on sale and lease back, lease receipts and miscellaneous receipts). Our total income in Fiscals 2017 and 2016 was ₹ 7,052.19 million and ₹ 7,815.43 million, respectively.

Our revenue from operations decreased by 9.80% to ₹ 7,031.47 million in Fiscal 2017 from ₹ 7,795.20 million in Fiscal 2016, primarily due to the continuing global slowdown in the agriculture and construction equipment industries in Fiscal 2017, as well as reduction in the aftermarket sales to one of our largest customers in this segment due to liquidation of inventory by it, which was partly offset by increase in sales to domestic customers.

Our 3PL vertical accounted for 48.61% and 49.27%; our PMP vertical accounted for 44.20% and 44.09%; our PTO vertical accounted for 1.18% and 1.13% and our hydraulic cylinders vertical accounted for 0.27% and 0.20% of our revenue from operations in Fiscals 2017 and 2016, respectively. Further, our International Sales accounted for 81.38% and 84.55% of our revenue from operations in Fiscals 2017 and 2016, respectively. Local Deliveries contributed to 38.27% and 38.11% of our sale of revenue from operations in Fiscals 2017 and 2016, respectively, while Direct Exports contributed to 26.49% and 27.26%, respectively, and Warehouse Sales contributed to 31.66 and 31.30%, respectively, during the same periods.

Sale of finished goods: Our sale of finished goods [net of returns, rebate etc.] decreased to ₹ 6,779.69 million in Fiscal 2017 from ₹ 7,535.23 million in Fiscal 2016.

Sale of scrap: Our sales of scrap increased to ₹ 129.60 million in Fiscal 2017 from ₹ 128.97 million in Fiscal 2016.

#### *Expenses*

Our total expenses decreased by 7.51% to ₹ 6,657.12 million in Fiscal 2017 from ₹ 7,197.93 million in Fiscal 2016, on account of reduced business volumes. As a percentage of our total income, our total expenses increased to 94.40% in Fiscal 2017 from 92.10% in Fiscal 2016.

Cost of raw materials and components consumed and changes in inventory: Our cost of raw materials and components consumed (which primarily consists of steel) including change in inventory, decreased by 12.54% to ₹ 2,417.77 million in Fiscal 2017 from ₹ 2,764.42 million in Fiscal 2016, in line with the reduction in our sales of finished goods.

As a percentage of our total income, cost of raw materials and components consumed (net of changes in inventory) decreased to 34.28% in Fiscal 2017 from 35.37% in Fiscal 2016, primarily as a result of declining steel prices (the benefit of which was passed on to the customers after a lag) as well as operating and purchasing efficiencies.

Employee benefit expenses: Our employee benefit expenses, which primarily consist of salaries and wages, contribution to provident and other funds, expense on employee stock option scheme and staff welfare expenses, reduced to ₹ 1,581.81 million in Fiscal 2017 from ₹ 1,595.76 million in Fiscal 2016, primarily due to a decrease in the number of personnel engaged by us in the U.S., in line with the decrease in production. As a percentage of our total income, employee benefit expenses increased to 22.43% in Fiscal 2017 from 20.42% in Fiscal 2016, as a result of decrease in total income in Fiscal 2017.

#### Depreciation and amortization expense

Our depreciation and amortization expense increased by 6.90% to ₹ 197.66 million in Fiscal 2017 from ₹ 184.89 million in Fiscal 2016, as a result of additional capital expenditure of ₹ 138.93 million in plant and machinery, as well as investments made in other assets, including IT infrastructure.

## Finance costs

Our finance costs, which primarily consist of interest, bill discounting charges and bank charges, decreased by 13.87% to ₹ 86.55 million in Fiscal 2017 from ₹ 100.48 million in Fiscal 2016, as a result of a decrease in outstanding borrowings. Our total debt decreased from ₹ 2,303.93 million as of March 31, 2016 to ₹ 1,947.86 million as of March 31, 2017. As a percentage of our total income, finance costs decreased to 1.23% in Fiscal 2017 from 1.29% in Fiscal 2016.

**Other expenses:** Our other expenses, which primarily consists of stores, spares and tools consumed, sub-contracting expenses, power, fuel and water, cartage, freight and forwarding, rent and repairs and maintenance, reduced to ₹ 2,266.87 million in Fiscal 2017 from ₹ 2,446.03 million in Fiscal 2016, primarily as a result of our reduced production due to the downturn in global agriculture and construction equipment market. As a percentage of our total income, our other expenses increased to 32.14% in Fiscal 2017 from 31.30% in Fiscal 2016.

## EBITDA

As a result of the foregoing, our EBITDA reduced by 24.76% to ₹ 679.28 million in Fiscal 2017 from ₹ 902.88 million in Fiscal 2016. EBITDA, as a percentage of our total income reduced to 9.63% in Fiscal 2017 from 11.55% in Fiscal 2016.

## Profit before tax

Our profit before tax decreased by 36.02% to ₹ 395.07 million in Fiscal 2017 from ₹ 617.50 million in Fiscal 2016, largely due to the factors discussed above.

## Total tax expense

Our total tax expense decreased by 23.78% to ₹ 129.87 million in Fiscal 2017 from ₹ 170.39 million in Fiscal 2016, largely as a result of decrease in profit in Fiscal 2017.

## Profit for the period/ year

As a result of the foregoing, our profit for the year decreased by 40.69% to ₹ 265.20 million in Fiscal 2017 from ₹ 447.12 million in Fiscal 2016. Our profit for the year, as a percentage of our total income, decreased to 3.76% in Fiscal 2017 from 5.72% in Fiscal 2016.

## Liquidity and Capital Resources

As on September 30, 2018 and March 31, 2018, 2017 and 2016, we had cash and cash equivalents of ₹ 102.66 million, ₹ 91.49 million, ₹ 56.36 million and ₹ 50.67 million, respectively. Our primary requirements for liquidity are working capital, ongoing capital expenditure and general corporate needs. Our primary sources of liquidity and capital resources are cash generated from operating activities and borrowings from banks and financial institutions.

Set forth below is a table of selected information from our Company's statements of cash flows for the period indicated.

(₹ in million)

Particulars	As on September 30, 2018	As on March 31, 2018	As on March 31, 2017	As on March 31, 2016
Net cash flow from/(used in) operating activities	(207.57)	(56.26)	679.86	477.58
Net cash flow from/(used in) investing activities	(300.02)	(416.59)	(242.68)	(394.13)
Net cash flow from/(used in) financing activities	552.30	466.16	(434.30)	23.81
Net increase/(decrease) in cash and cash equivalents	44.71	(6.69)	2.88	107.26
Cash & cash equivalent balance at the beginning of the year	91.49	56.36	50.67	36.09
Net Increase/(Decrease) in temporary overdraft	(32.64)	39.29	4.17	(94.64)
Effects of exchange difference on cash and cash equivalent held in foreign currency	(0.90)	2.53	(1.36)	1.95
<b>Cash and cash equivalent balance at the end of the period/year</b>	<b>102.66</b>	<b>91.49</b>	<b>56.36</b>	<b>50.67</b>

## Cash flow from operating activities

Our net cash used in operating activities for the six months ending September 30, 2018 was ₹ 207.57 million. Our cash flows used in operating activities for this period were negatively impacted primarily due to increase in working capital by ₹ 722.27 million. Such increase in working capital was primarily on account of an increase in inventory by ₹ 743.15 million due to our strategy of focusing on increasing our Warehouse Sales, which inherently involves longer inventory cycles.

Our net cash used in operating activities in Fiscal 2018 was ₹ 56.26 million. Our cash flows used in operating activities for this period were negatively impacted primarily due to increase in working capital by ₹ 776.16 million consequent to the

increase in inventory by ₹ 768.26 million. This increase in working capital requirements was consistent with the growth in our business during Fiscal 2018. While our working capital requirements increased in Fiscal 2018, the growth in our business has also driven an increase in our profitability during this period.

Our net cash from operating activities in Fiscal 2017 was ₹ 679.86 million. Our cash flows from operating activities for this period were positively impacted primarily due to an increase in payables of ₹ 26.64 million, decrease in income tax asset by ₹ 55.32 million, decrease in other current assets by ₹ 63.50 million, decrease in inventory by ₹ 13.67 million, increase in non-current provision by ₹ 11.36 million and increase in other current liabilities of ₹ 54.88 million which was partially offset by an increase in trade receivables of ₹ 25.24 million and increase in non-current asset by ₹ 15.87 million, respectively.

Our net cash from operating activities in Fiscal 2016 was ₹ 477.58 million. Our cash flows from operating activities for this period were positively impacted primarily due to increased profitability as a result of improved margins and better working capital management.

#### *Cash flow from investing activities*

Our net cash used in investing activities for the six months ended September 30, 2018 was ₹ 300.02 million, primarily on account of purchase of fixed assets including intangible assets. We invested ₹ 300.20 million in plant and machinery (primarily at our new facility at Ludhiana and one of our existing facilities at Noida) and ₹ 146.53 million in building (a significant portion of which related to our new facility at Ludhiana). There was a decrease in capital work in progress of ₹ 155.91 million (including intangible assets under development) and the balance investment was made in other assets, including IT infrastructure.

Our net cash used in investing activities in Fiscal 2018 was ₹ 416.59 million, primarily on account of purchases of fixed assets (including intangible assets) in line with our growth plans. We invested ₹ 206.82 million in plant and machinery across all our existing facilities, ₹ 12.96 million in building and ₹ 187.44 million worth of addition was in capital work in progress / assets under development (including intangible assets). Balance investment was made in other assets, including IT infrastructure.

Our net cash used in investing activities in Fiscal 2017 was ₹ 242.68 million, primarily on account of purchase of fixed assets (including intangible assets). We invested ₹ 138.93 million in plant and machinery across all our existing facilities and an addition of ₹ 93.44 million in capital work in progress / assets under development (including intangible assets). Balance investment made in other assets, including IT infrastructure.

Our net cash used in investing activities in Fiscal 2016 was ₹ 394.13 million, primarily on account of purchase of fixed assets (including intangible assets) of ₹ 406.95 million. We invested ₹ 259.43 million in plant and machinery across all our existing facilities, ₹ 73.88 million in leasehold land majority of which was for our new facility at Ludhiana and ₹ 38.36 million in building. Balance investment was made in other assets including IT infrastructure.

#### *Cash flow used in financing activities*

Our net cash flow from financing activities for the six months ended was ₹ 552.30 million, which primarily comprised of an increase of ₹ 688.07 million in current borrowings, which was partially offset by payment of dividend of ₹ 54.41 million, payment of long term borrowings ₹ 22.28 million and payment of finance cost of ₹ 59.08 million. The increase in the short-term (current) borrowings was on account of the increase in overall sales, as well as in the proportion of Warehouse Sales, in particular.

Our net cash from financing activities in Fiscal 2018 was ₹ 466.16 million, which primarily comprised ₹ 474.46 million from the short-term (current) borrowings and net increase in term loans by ₹ 64.30 million, which was offset by interest paid of ₹ 72.60 million. The increase in our borrowings was due to the increase in our sales during this period and funding our capital expenditure requirements.

Our net cash used in financing activities in Fiscal 2017 was ₹ 434.30 million, which primarily comprised of repayment of short-term (current) borrowings of ₹ 242.99 million, repayment of long term borrowings of ₹ 119.51 million and interest paid of ₹ 71.80 million.

Our net cash flow from financing activities in Fiscal 2016 was ₹ 23.81 million, which primarily comprised of repayment of long-term borrowings of ₹ 17.16 million, dividend payment of ₹ 40.93 million and interest payment of ₹ 85.89 million which was offset by increase in short term borrowing of ₹ 167.79 million.

#### **Capital expenditure**

Our capital expenditure principally includes purchases of machinery and equipment, furniture and fixtures and IT infrastructure. Land and buildings are added infrequently on specific need basis.

## Indebtedness

Our business requires significant amount of working capital, primarily on account of high inventory levels owing to our backward integrated manufacturing operations as well as forward integrated warehousing as part of our global service delivery model.

As on September 30, 2018 and March 31, 2018, our consolidated debt aggregated to ₹ 3,131.22 million and ₹ 2,471.25 million, respectively, which consisted primarily of long term secured loans from banks and financial institutions amounting to ₹ 220.70 million and ₹ 242.98 million, respectively, long term secured loans (maturing within 12 months) from banks and financial institutions of ₹ 118.90 million and ₹ 124.71 million, respectively, and short term secured working capital loans of ₹ 2,791.62 million and ₹ 2,103.56 million (including bill discounting with banks of ₹ 33.58 million ₹ 37.87 million), respectively.

The following table sets out the principal elements of our indebtedness on a consolidated basis, as on September 30, 2018 and as on March 31, 2018, 2017 and 2016.

(₹ in million)

Particulars	As on September 30, 2018	As on March 31, 2018	As on March 31, 2017	As on March 31, 2016
<b>Non-current borrowings</b>				
Rupee loans from banks (Secured)	0.15	0.15	1.09	106.25
Rupee Loan from Others (Secured)	0.59	0.36	3.38	5.52
Foreign Currency Loan from Banks	218.81	241.14	172.38	186.08
Foreign Currency Loan from Others	1.14	1.33	1.82	0.34
<b>Current borrowings</b>				
Rupee Loan from Banks (Secured)	0.48	0.94	0.85	75.38
Rupee Loan from Others (Secured)	0.05	0.56	1.06	2.12
Foreign Currency Loan from Banks	117.76	122.71	137.68	54.19
Foreign Currency Loan from others	0.61	0.50	0.50	1.96
Bill discounting with Bank	33.58	37.87	29.77	21.33
Working capital loans :				
Foreign Currency Loans	1,597.96	1,299.39	1,082.49	1,064.11
Revolving Credit Facility/Lines of Credit	949.13	706.30	466.84	563.15
Indian Rupee Loan	210.96	60.00	50.00	223.50
<b>Total debt</b>	<b>3,131.22</b>	<b>2,471.25</b>	<b>1,947.86</b>	<b>2,303.93</b>

For more information, see “Financial Indebtedness” beginning on page 238.

## Capital and other commitments

As of September 30, 2018, we had the following capital and other commitments, as disclosed in the notes to our Restated Financial Statements:

(₹ in million)

Particulars	As at September 30, 2018
<b>(i) Claims against the company not acknowledged as debt:</b>	
-Sales Tax Matters	2.34
-Service Tax Matters	0.23
-Custom Matters	1.60
-Excise Matters	0.94
-Labour Matters	Not Ascertainable
<b>(ii) Sales tax liability against pending forms</b>	0.74
<b>(iii) Income tax demands</b>	0.36
<b>(iv) Others</b>	
Guarantees given on behalf of the Company by the Banks:	
-Sales tax matters	0.03
-Pollution control board	0.02
-Excise matters	0.50
- Custom matters	0.00
- Gas connections	2.68
<b>(v) Estimated amount of contracts remaining to be executed on Capital Accounts and not provided for (Net of Advances)</b>	120.24
<b>(vi) Other money for which the Company is contingently liable:</b>	
Guarantees given on behalf of the Company by others:	
Stand-by letter of credit for wholly-owned subsidiaries	9.25
<b>(vi) Bond cum Legal Undertaking to Andhra Pradesh Special Economic Zone and Noida Special Economic Zone</b>	1,699.73

For details of our outstanding tax, labor and other matters, see “*Outstanding Litigation and Material Developments*” beginning on page 254.

### **Quantitative and qualitative disclosure about market risk**

We are exposed to various types of market risks during the normal course of business. We are exposed to commodity risk, foreign exchange risk, interest rate risk and credit risk in the normal course of our business.

#### ***Commodity price risk***

Commodity price risk is the possibility of impact from changes in the prices of raw materials such as steel, which we use in the manufacture of our products. Raw material supply and pricing can be volatile due to a number of factors beyond our control, including global demand and supply, general economic and political conditions, transportation and labor costs, labor unrest, natural disasters, competition, import duties, tariffs and currency exchange rates. This volatility in commodity prices (in particular, the cost of steel) can significantly affect our raw material costs. Further, volatility in fuel prices can also affect commodity prices worldwide which may increase our raw material costs. While we typically agree to renegotiate/reset prices of our products to include adjustments beyond a specific range (which may vary between customers), as this is done on a periodic basis and prices are otherwise generally fixed, we may not be able to pass on increase in raw material to our customers within this range or at all, we may not be able to fully achieve this in all situations or at all times.

#### ***Foreign exchange risk***

We are exposed to foreign exchange rate fluctuations in respect of (i) our foreign currency denominated borrowings (mainly in US\$), (ii) currency mismatches between our revenues and expenses, which we seek to manage as much as possible by matching income currency to expenditure currency, and (iii) currency translation losses for the purpose of preparing our consolidated financial statements (which are presented in Indian Rupees), on account of our global operations. For further details on this risk, see “– *Significant factors affecting our results of operations and financial condition – Foreign currency fluctuations*” on page 143.

#### ***Interest rate risk***

We are subject to market interest risks due to fluctuations in interest rates primarily in relation to our debt obligations with floating interest rates. As on September 30, 2018 and as on March 31, 2018, 89.04% and 84.89%, respectively, of our total consolidated loans (excluding bills discounting with bank) carried floating interest rate. The interest rate on remaining loans (except vehicle loans), although fixed, is subject to periodic review by lending banks / financial institutions in relation to their respective base lending rates, which may vary over a period result of any change in the monetary policy of the Reserve Bank of India.

#### ***Inflation risk***

Inflationary factors such as increases in the input costs and overhead costs may adversely affect our operating results. There may be time lag in recovering the inflation impact from our customer and we may not be able to recover the full impact of such inflation. A high rate of inflation in the future may, therefore, have an adverse effect on our ability to maintain our profit margins.

#### ***Credit risk***

We are subject to the risk that our counterparties under various financial or customer agreements will not meet their obligations. Our credit risk exposure relates to our operating activities and our financing activities, including deposits with banks and financial institutions, foreign exchange transactions and other financial instruments. Our operations involve extending credit for periods of time, ranging typically from 0 to 90 days, to our customers and consequently, we face the risk of the uncertainty regarding the receipt of these outstanding amounts. Accordingly, we may have high levels of outstanding receivables. As on September 30, 2018, our trade receivables were ₹ 1,453.67 million and trade receivables outstanding for a period of over 180 days (net of allowance for doubtful debts) as of September 30, 2018 were ₹ 27.71 million.

In relation to credit risk arising from financing activities, we monitor our credit spreads and financial strength on a regular basis, and based on our on-going assessment of counterparty risk, we adjust our exposure to various counterparties.

#### ***Related party transactions***

We have, in the ordinary course of our business, entered into transactions with certain related parties. For instance, we have in the past purchased goods and samples from and sold goods to and may in the future continue to purchase goods and samples from and sell goods to related parties. Further, our Registered Office is located in premises that are leased from a related party, Soni Holdings (partnership firm). Some of our loans have been secured by collaterals and personal guarantees of our Promoters and Promoter Group entities.

While, in our view, all such related party transactions were conducted on an arms' length basis, we cannot assure you that we could not have achieved more favorable terms had such arrangements not been entered into with related parties. Further, we cannot assure you that these or any future related party transactions that we may enter into, individually or in the aggregate, will not have an adverse effect on our financial condition and results of operations.

For information on our related party transactions, see "*Risk Factors*" and "*Financial Statements*" beginning on pages 21 and 162, respectively.

**Significant developments after September 30, 2018**

In the opinion of our Board, other than as disclosed elsewhere in this Draft Red Herring Prospectus, there have not arisen any circumstances since September 30, 2018, which materially and adversely affect or are likely to materially and adversely affect our business or profitability, the value of our assets or our ability to pay our liabilities within the next 12 months.



## SECTION VI: LEGAL AND OTHER INFORMATION

### OUTSTANDING LITIGATION AND MATERIAL DEVELOPMENTS

Except as stated in this section, there are no outstanding (I) criminal proceedings, (II) actions taken by statutory or regulatory authorities, (III) disciplinary action including penalty imposed by the SEBI or stock exchanges against our Promoters in the last five Fiscals, including outstanding action, (IV) claims related to direct and indirect taxes in a consolidated manner, (V) details of any other pending material litigation which are determined to be material as per a policy adopted by our Board ("**Materiality Policy**"), in each case involving our Company, Promoters, Directors and Subsidiaries, (the "**Relevant Parties**").

For the purpose of (V) above, our Board in its meeting held on November 23, 2018, has considered and adopted a policy of materiality for identification of material litigation involving the Relevant Parties and Group Company.

- (1) In terms of the Materiality Policy, all pending litigation involving the Relevant Parties, other than criminal proceedings, actions by regulatory authorities and statutory authorities, disciplinary action including penalty imposed by SEBI or stock exchanges against the Promoters in the last five Fiscals including outstanding action, and tax matters, would be considered 'material' if:
- (a) the monetary amount of claim by or against the entity or person in any such pending proceeding is in excess of 1% of the profit after tax of our Company as per the restated consolidated financial statements of our Company for the last full Fiscal, being ₹ 5.35 million; or
  - (b) the monetary liability is not quantifiable, however, the outcome of any such pending proceedings may have a bearing on the business, operations, performance, prospects or reputation of our Company.

Except as stated in this section, there are no outstanding litigation involving our Group Company which have a material impact on our Company.

Except as stated in this section, there are no outstanding material dues to creditors of our Company. For this purpose, our Board in its meeting held on November 23, 2018, has considered and adopted a policy of materiality for identification of material outstanding dues to creditors. In terms of this materiality policy, outstanding dues to any creditor of our Company having monetary value which exceed ₹ 52.93 million, which is 5% of the total consolidated trade payables of our Company as per the latest Restated Financial Information of our Company included in this Draft Red Herring Prospectus, shall be considered as 'material'. Accordingly, during September 30, 2018, any outstanding dues exceeding ₹ 52.93 million have been considered as material outstanding dues for the purposes of disclosure in this section. Further, for outstanding dues to any party which is a micro, small or a medium enterprise ("**MSME**"), the disclosure will be based on information available with our Company regarding status of the creditor as defined under Section 2 of the Micro, Small and Medium Enterprises Development Act, 2006, as amended, as has been relied upon by the Statutory Auditors.

#### Litigation involving our Company

##### Litigation against our Company

##### A. Actions taken by regulatory and statutory authorities

Devender Singh, an ex-employee of our Company, who was employed at SKG Engineering Co. ("**SKG**"), a unit of our Company, had filed an application dated October 19, 2015 with SKG, demanding a payment of ₹ 0.23 million as gratuity. SKG denied this demand by a letter dated November 3, 2015, stating that Devender Singh had not completed five years of service and, accordingly, was not entitled to receive gratuity under the provisions of the Payment of Gratuity Act, 1972 ("**Gratuity Act**"). Thereafter, SKG received a notice from the Controlling Authority under the Gratuity Act and Labour cum Conciliation Officer, Circle-1, Ludhiana ("**Labour Authority**") requiring the presence of the officials of our Company in relation to payment of gratuity to Devender Singh. The matter is pending before the Labour Authority.

##### B. Tax Claims

We have disclosed claims relating to direct and indirect taxes involving our Company in a consolidated manner giving details of number of cases and total amount involved in such claims.

Particulars	Number of cases	Aggregate amount involved* (in ₹ million)
<b>Indirect Tax</b>		
Central Excise	7	0.94
VAT	6	2.25
Customs	1	1.60

Particulars	Number of cases	Aggregate amount involved* (in ₹ million)
Service Tax	1	0.23
<b>Direct Tax</b>	20	73.08
<b>Total</b>	<b>35</b>	<b>78.10</b>

\* To the extent ascertainable.

### **Litigation by our Company**

#### **A. Criminal Proceedings**

- Our Company filed a complaint dated February 28, 2018 (“**Complaint**”) under the provisions of the Indian Penal Code, 1860 and the Information Technology Act, 2000 with SHO, Police Station, Vasant Kunj, New Delhi against certain unknown hacker(s). Under the Complaint, the Company has alleged commission of, inter alia, fraud and theft by such unknown hacker(s) against our Company and its customers by creating fake e-mail ids. The unknown hacker(s) had misguided the customers of our Company by requesting them to send outstanding monies to unauthorized bank accounts. Our Company has further alleged in the Complaint that the total amount involved in the fraud is ₹ 19.22 million. The Company has not suffered any direct monetary loss due to the alleged fraud. The matter is pending.

#### **B. Other Pending Material Litigation**

- Our Company had placed an order with Mysore Kirloskar Limited (“**MKL**”) on July 24, 2000 for supply of 10 machines for a total consideration of ₹ 14.00 million which was accepted by MKL by its letters dated August 2, 2000 and August 3, 2000 and acknowledged by MKL vide letter dated August 14, 2000. Our Company was informed that MKL had filed a reference under Section 15(1) of the Sick Industrial Companies (Special Provisions) Act, 1985 before the Board for Industrial and Financial Reconstruction (“**BIFR**”). On account of MKL’s failure to deliver the machines on the date of delivery, our Company issued a legal notice dated March 21, 2001 to MKL and its directors. Subsequently, the BIFR by its order dated October 31, 2002 directed MKL to be wound up and an Official Liquidator was appointed. Thereafter, our Company moved an application under Section 22(1) of the Sick Industrial Companies (Special Provisions) Act, 1985 before the BIFR seeking permission to file appropriate legal proceedings against MKL which however was not allowed. Thereafter, our Company filed a claim petition dated June 18, 2005 before the Official Liquidator, Bangalore claiming ₹ 67.89 million on account of the default.

### **Litigation involving our Directors**

#### **Litigation against our Directors**

#### **A. Tax Claims**

Particulars	Number of cases	Aggregate amount involved* (in ₹ million)
<b>Indirect Tax</b>	-	-
<b>Direct Tax</b>		
<i>Gurdeep Soni</i>	3	0.44
<i>Paramjit Singh Soni</i>	3	1.32
<b>Total</b>	<b>6</b>	<b>1.76</b>

\* To the extent ascertainable.

### **Litigation involving our Promoters**

#### **Litigation against our Promoters**

For details in relation to litigation against our Promoters, see “*Litigation involving our Directors – Litigation against our Directors – Tax Claims*” on page 255.

#### **Disciplinary action against our Promoters by SEBI or any stock exchange in the last five Fiscals**

As on the date of this Draft Red Herring Prospectus, no disciplinary action including penalty imposed by SEBI or stock exchanges has been initiated against our Promoters in the last five Fiscals including any outstanding action.

### **Litigation involving our Subsidiaries**

#### **Litigation against our Subsidiaries**

#### **A. Gripwel Fasteners Private Limited**

## 1. Tax Claims

We have disclosed claims relating to direct and indirect taxes involving GFPL in a consolidated manner giving details of number of cases and total amount involved in such claims.

Particulars	Number of cases	Aggregate amount involved* (in ₹ million)
<b>Indirect Tax</b>		
VAT	1	0.03
<b>Direct Tax</b>	4	1.59
<b>Total</b>	<b>5</b>	<b>1.62</b>

\* To the extent ascertainable.

### Outstanding dues to Creditors

As of September 30, 2018, we had 1,457 creditors on a consolidated basis. The aggregate amount outstanding to such creditors as on September 30, 2018 was ₹ 1,058.56 million, on a consolidated basis.

As per the Materiality Policy, such creditors to whom, outstanding dues to any creditor of our Company having monetary value which exceed ₹ 52.93 million, which is 5% of the total trade payables of our Company as per the Restated Financial Statements of our Company included in this Draft Red Herring Prospectus, shall be considered as 'material'. Accordingly, in this regard, the creditors to whom an amount exceeding ₹ 52.93 million was owed as on September 30, 2018, were considered 'material' creditors. Based on the above, there is one material creditor of our Company as on September 30, 2018, to whom an aggregate amount of ₹ 55.74 million was outstanding on such date.

Details of outstanding dues owed as at September 30, 2018 to MSMEs and other creditors are set out below.

Creditors	Number of Cases	Amount due (in ₹ million)
MSMEs	43	6.25
Other creditors	1,413	1,058.56

The details pertaining to amounts due towards the material creditors are available on the website of our Company at <https://unipartsgroup.com/investor-corporate-ms.asp?links=inv2d>.

### Material Developments

Except as disclosed in "Management's Discussion And Analysis of Financial Condition and Results of Operations" beginning on page 241, there have not arisen since September 30, 2018, the date of the last Restated Financial Statements included in this Draft Red Herring Prospectus, any circumstances which materially and adversely affect, or are likely to affect, our profitability or operations taken as a whole or the value of our consolidated assets or our ability to pay our material liabilities within the next 12 months.

## GOVERNMENT AND OTHER APPROVALS

*Except as disclosed herein and in “Risk Factors” on page 21, we have obtained all material consents, licenses, permissions and approvals from various governmental, statutory and regulatory authorities in India for our manufacturing facilities and warehouses, distribution centres and raw material storage space which are necessary for undertaking our business. The list below is indicative and does not include Offer and incorporation related approvals, which are set out in the sections entitled “Other Regulatory and Statutory Disclosures” and “History and Certain Corporate Matters” beginning on pages 261 and 136, respectively. In view of these approvals, our Company and its Subsidiaries can undertake their current business activities. Unless stated otherwise, we have obtained necessary approvals from the relevant government authorities with respect to our manufacturing facilities and warehouses and such approvals are valid as on the date of this Draft Red Herring Prospectus.*

The material approvals, consents, licenses, registrations and permits obtained by our Company and its Material Subsidiaries, which enable it to undertake its current business activities, are set out below:

### 1. **Material approvals in relation to our business operations**

*Material approvals in relation to our operational manufacturing facilities at (i) Noida (two units – one unit of our Company and the other of our Subsidiary, GFPL), Uttar Pradesh; (ii) Visakhapatnam, Andhra Pradesh; and (iii) Ludhiana (two units), Punjab:*

- (a) Consent to operate issued by the respective pollution control board under the Water (Prevention and Control of Pollution) Act, 1974;
- (b) Consent to operate issued by the respective pollution control board under the Air (Prevention and Control of Pollution) Act, 1981;
- (c) Authorisation for generation, storage and disposal of hazardous wastes issued by the respective pollution control board under the Hazardous and other Wastes (Management and Transboundary Movement) Rules, 2016;
- (d) License to work a factory issued by the relevant State Government under the Factories Act, 1948;
- (e) Certificate of registration of establishments employing contract labour issued by the office of the registering officer, under the Contract Labour (Regulation and Abolition) Act, 1970;
- (f) No objection certificate issued by the fire department of the local municipal corporations of the respective states where our manufacturing facilities are located;
- (g) Registration of establishment for employees’ provident fund issued by the Employees’ Provident Fund Organisation under the Employees’ Provident Funds and Miscellaneous Provisions Act, 1952;
- (h) Registration of factory/establishment for employees’ insurance issued by the relevant regional office of the Employees State Insurance Corporation of different states in India under the Employees' State Insurance Act, 1948;
- (i) Letter of approval for continued operations in Special Economic Zones issued by the Office of Development Commissioner, Ministry of Commerce and Industry for our manufacturing facility at Visakhapatnam and for one unit of our Subsidiary, GFPL, at Noida; and
- (j) License to store propane gas in pressure vessels issued by the Petroleum and Explosives Safety Organisation for our manufacturing facility at Visakhapatnam.

*Material approvals in relation to our under-construction manufacturing facility at Ludhiana, Punjab:*

- (a) No objection certificate issued by the fire department of Ludhiana.

*Material approvals in relation to our (i) distribution centre; and (ii) raw material storage space at Noida, Uttar Pradesh:*

- (a) Registration certificate of shops or commercial establishments issued by the labour department under the Uttar Pradesh Shops and Commercial Establishment Act, 1962; and
- (b) No objection certificate issued by the fire department.

2. **Tax related approvals of our Company**

- (a) Permanent account number AAACU0454D issued by the Income Tax Department under the Income Tax Act, 1961;
- (b) GST Registration number 09AAACU0454D3ZM of our corporate office for GST payments under the Central Goods and Services Tax Act, 2017 and Uttar Pradesh Goods and Services Act, 2017; and
- (c) GST registration numbers of our manufacturing facilities, distribution centre and raw material storage space for GST payments under the central and state goods and services tax legislations.

3. **Other material approvals**

- (a) Certificate of registration of establishment issued by the Department of Labour under the Delhi Shops and Establishment Act, 1954 for the registered office of our Company;
- (b) Certificate of registration of establishment issued by the Department of Labour under the Uttar Pradesh Shops and Establishment Act, 1962 for the corporate office of our Company;
- (c) Certificate of importer-exporter code issued by the Ministry of Commerce and Industry for our Company and one of our Subsidiaries, GFPL; and
- (d) Registration cum membership certificate as a manufacturer exporter issued by the Engineering Export Promotion Council.

4. **Material approvals in relation to our foreign Subsidiaries**

- (a) Business license issued by the Columbia and Richmond County for our Subsidiary, UUL for right to operate its facilities;
- (b) VAT ID number DE815194395 issued by the Federal Central Tax Office for our Subsidiary, UIG for carrying on its international business; and
- (c) Trade and business registration issued by the Commercial Registration Office Hennef (Sieg) for our Subsidiary, UIG for starting its business.

5. **Material approvals applied for but not received**

Our Company and its Subsidiaries have obtained approvals from the relevant central or state government authorities for grant of material approvals, consents, licenses, registrations and permits that are required by our Company and its Subsidiaries for undertaking its current business activities.

6. **Renewals applied for in relation to material approvals but not yet received**

Our Company has made the following applications to the relevant central or state government authorities for renewal of material approvals, consents, licenses, registrations and permits that are required by our Company for undertaking its current business activities:

- (a) Application dated October 24, 2018 for obtaining consent to establish under the Air (Prevention and Control of Pollution) Act, 1981 and Water (Prevention and Control of Pollution) Act, 1974 along with renewal of consolidated consent to operate under the Air (Prevention and Control of Pollution) Act, 1981 and the Water (Prevention and Control of Pollution) Act, 1974 and authorization under the Hazardous and other Wastes (Management and Transboundary Movement) Rules, 2016 made to the Punjab Pollution Control Board for our manufacturing facility at Ludhiana, Punjab; and
- (b) Application dated September 4, 2018 made to the Chief Fire Officer for renewal of no objection certificate issued for the manufacturing facility of our Subsidiary, GFPL at Noida, Uttar Pradesh.

7. **Material approvals required, yet to be applied for**

Our Company and its Subsidiaries have obtained approvals from the relevant central or state government authorities for material approvals, consents, licenses, registrations and permits that are required by our Company and its Subsidiaries for undertaking its current business activities.

## OUR GROUP COMPANY

In accordance with the SEBI ICDR Regulations and the applicable accounting standards, for the purpose of identification of group companies, our Company has considered (i) the companies (other than the direct and indirect Subsidiaries) with which there are related party transactions, as disclosed in the Restated Financial Statements; (ii) the companies which are members of the Promoter Group and with which there were related party transactions in the most recent Fiscal for which Restated Financial Statements are included in this Draft Red Herring Prospectus which, individually or in the aggregate, exceed 10% of the total restated consolidated revenues of our Company for such Fiscal; and (iii) a related parties with which there were transactions for the period (after the stub period in respect of which, the Restated Financial Statements) are included in this Draft Red Herring Prospectus.

Accordingly, in terms of the policy adopted by our Board for determining group companies, our Board has identified SKG Engineering Private Limited (“SKG”) as a group company.

### Details of our Group Company

#### *SKG Engineering Private Limited*

##### *Corporate Information*

SKG was incorporated on March 16, 1995 under the Companies Act, 1956. The corporate identity number of SKG is U74899DL1995PTC066464.

##### *Nature of Activities*

SKG is authorised by its memorandum of association, to carry out the business of manufacturing, selling and export of precision engineering products and allied engineering products.

##### *Financial Performance*

The financial information derived from the audited financial results of SKG for the Fiscals 2018, 2017 and 2016 are set forth below:

*(Figures in ₹ million except per share data)*

Particulars	Fiscal		
	2018	2017	2016
Equity capital	0.99	0.99	0.99
Reserves and surplus (excluding revaluation reserve)	177.82	166.15	164.72
Sales/ turnover	-	-	0.67
Profit/(Loss) after tax	11.67	1.43	50.55
Earnings per share (Basic)	117.79	14.45	510.08
Earnings per share (Diluted)	117.79	14.45	510.08
Net asset value per share	1,804.39	1,686.60	1,672.15

There are no significant notes by the auditors in relation to the above mentioned financial statements for the specified last three Fiscals.

### Litigation

As on the date of this Draft Red Herring Prospectus, there are no outstanding litigation involving our Group Company which have a material impact on our Company.

### Group Company which is a sick industrial company

Our Group Company has not become a sick company under the erstwhile Sick Industrial Companies (Special Provisions) Act, 1985.

### Group Company under winding up/insolvency proceedings

Our Group Company is not under winding up/insolvency proceedings.

### Loss making Group Company

SKG is not a loss making Group Company.

### Defunct Group Company

During the five years immediately preceding the date of this Draft Red Herring Prospectus, our Group Company has not remained defunct and no application has been made to the relevant registrar of companies for striking off the name of our Group Company.

**Common pursuits**

There are no common pursuits amongst our Group Company and our Company. All our Subsidiaries are either engaged in or are authorised by their respective constitutional documents to engage in the same line of business as that of our Company. We will adopt the necessary procedures and practices as permitted by law to address any conflict situation, if and when they arise.

**Business interests or other interests**

Except as disclosed in “*Financial Information*” beginning on page 162, our Group Company and Subsidiaries do not have any business interest in our Company.

## OTHER REGULATORY AND STATUTORY DISCLOSURES

### Authority for the Offer

Our Board has approved the Offer pursuant to its resolution dated November 23, 2018 and our Shareholders have approved the Fresh Issue pursuant to a special resolution dated November 27, 2018 under Section 62(1)(c) of the Companies Act, 2013. Further, the Board has taken on record the approval for the Offer for Sale by the Selling Shareholders and has approved this Draft Red Herring Prospectus pursuant to its resolution dated December 5, 2018.

The Selling Shareholders have consented to participate in the Offer for Sale pursuant to their authorizations as set forth below:

S. No.	Names of the Selling Shareholders	Date of consent letter	Number of Equity Shares
<b>Investor Selling Shareholders</b>			
1.	Ambadevi Mauritius Holding Limited	December 4, 2018	2,154,192
2.	Ashoka Investment Holdings Limited	December 4, 2018	7,180,642
<b>Individual Selling Shareholders</b>			
3.	Andrew Warren Code	December 3, 2018	177,378
4.	Bradley Lorenz Miller	December 3, 2018	16,366
5.	Craig A Johnson	December 3, 2018	5,010
6.	Dennis Francis DeDecker	December 3, 2018	57,420
7.	Diana Lynn Craig	December 3, 2018	8,340
8.	James Norman Hallene	December 3, 2018	177,378
9.	Kevin John Code	December 3, 2018	177,378
10.	Marc Christopher Dorau	December 3, 2018	7,710
11.	Mark Louis Dawson	December 3, 2018	20,870
12.	Mary Louise Arp	December 3, 2018	10,440
13.	Meher Soni	December 3, 2018	1,444,280
14.	Melvin Keith Gibbs	December 3, 2018	41,730
15.	Misty Garcia	December 3, 2018	826
16.	Pamela Soni	December 3, 2018	1,534,548
17.	Walter James Gruber	December 3, 2018	24,706
18.	Wendy Reichard Hammen	December 3, 2018	21,556
<b>Total</b>			<b>13,060,770</b>

We will apply for an approval from the RBI for transfer of 1,444,280 Equity Shares from Meher Soni held by her on non-repatriation basis pursuant to the Offer for Sale to successful non-resident Bidders, immediately upon filing of this Draft Red Herring Prospectus with the SEBI.

### Prohibition by SEBI or other Governmental Authorities

Our Company, our Promoters, our Directors, the members of the Promoter Group, the persons in control of our Company and each of the Selling Shareholders have not been prohibited from accessing the capital markets and have not been debarred from buying, selling or dealing in securities under any order or direction passed by SEBI or any other regulatory or governmental authority or court, including any securities market regulator in any jurisdiction.

### Compliance with the Companies (Significant Beneficial Ownership) Rules, 2018

Our Company is in compliance with the Companies (Significant Beneficial Ownership) Rules, 2018 (“**SBO Rules**”), to the extent applicable, as on the date of the Draft Red Herring Prospectus.

Under the SBO Rules certain persons who are ‘significant beneficial owners’, are required to intimate their beneficial holdings to our Company in Form no. BEN-1. However, pursuant to the General Circular no. 8/2018 dated September 10, 2018 issued by the Ministry of Corporate Affairs, Government of India (“**MCA**”), filing of Form no. BEN – 1 under the SBO Rules has been deferred until further notification from MCA. Therefore, compliance by such Selling Shareholders, Promoters and members of the Promoter Group, with the SBO Rules, to the extent applicable to each of them will be completed only upon further notification by the MCA.

### Directors associated with the Securities Market

None of our Directors are, in any manner, associated with the securities market and there has been no action initiated by SEBI against the Directors of our Company in the five years preceding the date of this Draft Red Herring Prospectus.

### Eligibility for the Offer



Our Company is eligible for the Offer in accordance with the Regulation 6(1) of the SEBI ICDR Regulations, and is in compliance with the conditions specified therein in the following manner:

- Our Company has had net tangible assets of at least ₹ 30 million, calculated on a restated and consolidated basis, in each of the preceding three full years (of 12 months each), of which not more than 50 % are held in monetary assets;
- Our Company has an average operating profit of at least ₹ 150 million, calculated on a restated and consolidated basis, during the preceding three years (of 12 months each), with operating profit in each of these preceding three years;
- Our Company has a net worth of at least ₹ 10 million in each of the preceding three full years (of 12 months each), calculated on a restated and consolidated basis; and
- Our Company has not changed its name in the last one year.

Our Company's net tangible assets, monetary assets, monetary assets as a percentage of the net tangible assets, operating profits and net worth, derived from the Restated Financial Statements included in this Draft Red Herring Prospectus as at, and for the last three Fiscals ended March 31, 2018, 2017 and 2016 are set forth below:

(₹ in million, unless otherwise stated)

	Consolidated		
	Fiscal 2018	Fiscal 2017	Fiscal 2016
Net tangible assets, as restated <sup>(1)</sup>	7,113.17	5,824.42	5,860.16
Monetary assets, as restated <sup>(2)</sup>	91.49	56.36	50.67
Monetary assets, as a percentage of net tangible assets, as restated	1.29%	0.97%	0.86%
Operating profit <sup>(3)</sup>	796.56	481.62	717.98
Net worth, as restated <sup>(4)</sup>	3,616.95	3,150.67	2,914.90

Notes:

- (1) 'Net tangible assets' means the sum of all net assets of our Company, excluding intangible assets as defined in Accounting Standard 26 issued by the ICAI.
- (2) Monetary assets comprise cash and bank balances.
- (3) Operating profit means earnings before interest and tax. Average operating profits was ₹ 665.39 million based on the average of the three year profits.
- (4) 'Net worth' means the aggregate of paid up equity capital, share premium account, and reserves and surplus (excluding revaluation reserve) as reduced by the aggregate of miscellaneous expenditure (to the extent not adjusted or written off) and the debit balance of the statement of profit and loss account.

Our Company has operating profits in each of Fiscal 2016, 2017 and 2018 in terms of our restated consolidated summary statements.

Our Company confirms that it is in compliance with the conditions specified in Regulation 7(1) of the SEBI ICDR Regulations, to the extent applicable, and will ensure compliance with the conditions specified in Regulation 7(2) of the SEBI ICDR Regulations, to the extent applicable.

Further, our Company confirms that it is not ineligible to make the Offer in terms of Regulation 5 of the SEBI ICDR Regulations, to the extent applicable. The details of our compliance with Regulation 5 of the SEBI ICDR Regulations are as follows:

- (a) Neither our Company nor our Promoters, members of our Promoter Group, our Directors or any of the Selling Shareholders are debarred from accessing the capital markets by the SEBI.
- (b) None of our Promoters or Directors are promoters or directors of companies which are debarred from accessing the capital markets by the SEBI.
- (c) Neither our Company nor our Promoters, our Selling Shareholders or Directors is a wilful defaulter.
- (d) None of our Promoters or Directors is a fugitive economic offender.
- (e) There are no outstanding warrants, options or rights to convert debentures, loans or other instruments convertible into, or which would entitle any person any option to receive Equity Shares, as on the date of this Draft Red Herring Prospectus, except ESOPs.

Each of the Selling Shareholders, severally and not jointly, confirm that it is in compliance with Regulation 8 of the SEBI ICDR Regulations.

#### DISCLAIMER CLAUSE OF SEBI

**IT IS TO BE DISTINCTLY UNDERSTOOD THAT SUBMISSION OF THIS DRAFT RED HERRING PROSPECTUS TO SEBI SHOULD NOT, IN ANY WAY, BE DEEMED OR CONSTRUED THAT THE SAME HAS BEEN CLEARED OR APPROVED BY SEBI. SEBI DOES NOT TAKE ANY RESPONSIBILITY EITHER FOR THE FINANCIAL SOUNDNESS OF ANY SCHEME OR THE PROJECT FOR WHICH THE OFFER IS PROPOSED TO BE MADE OR FOR THE CORRECTNESS OF THE STATEMENTS MADE OR OPINIONS EXPRESSED IN THIS DRAFT RED HERRING PROSPECTUS. THE BRLMs, AXIS CAPITAL LIMITED, MOTILAL OSWAL INVESTMENT ADVISORS LIMITED AND SBI CAPITAL MARKETS LIMITED HAVE CERTIFIED THAT THE DISCLOSURES MADE IN THIS DRAFT RED HERRING PROSPECTUS ARE GENERALLY ADEQUATE AND ARE IN CONFORMITY WITH THE SECURITIES AND EXCHANGE BOARD OF INDIA (ISSUE OF CAPITAL AND DISCLOSURE REQUIREMENTS) REGULATIONS, 2018. THIS REQUIREMENT IS TO FACILITATE INVESTORS TO TAKE AN INFORMED DECISION FOR MAKING AN INVESTMENT IN THE PROPOSED OFFER.**

**IT SHOULD ALSO BE CLEARLY UNDERSTOOD THAT WHILE THE COMPANY IS PRIMARILY RESPONSIBLE FOR THE CORRECTNESS, ADEQUACY AND DISCLOSURE OF ALL RELEVANT INFORMATION IN THIS DRAFT RED HERRING PROSPECTUS, THE BRLMs ARE EXPECTED TO EXERCISE DUE DILIGENCE TO ENSURE THAT THE COMPANY DISCHARGES ITS RESPONSIBILITY ADEQUATELY IN THIS BEHALF AND TOWARDS THIS PURPOSE, THE BRLMs HAVE FURNISHED TO SEBI, A DUE DILIGENCE CERTIFICATE DATED DECEMBER 5, 2018 IN THE FORMAT PRESCRIBED UNDER SCHEDULE V(A) OF THE SECURITIES AND EXCHANGE BOARD OF INDIA (ISSUE OF CAPITAL AND DISCLOSURE REQUIREMENTS) REGULATIONS, 2018.**

**THE FILING OF THIS DRAFT RED HERRING PROSPECTUS DOES NOT, HOWEVER, ABSOLVE THE COMPANY FROM ANY LIABILITIES UNDER THE COMPANIES ACT, 2013 OR FROM THE REQUIREMENT OF OBTAINING SUCH STATUTORY AND/OR OTHER CLEARANCES AS MAY BE REQUIRED FOR THE PURPOSE OF THE OFFER. SEBI FURTHER RESERVES THE RIGHT TO TAKE UP, AT ANY POINT OF TIME, WITH THE BRLMs, ANY IRREGULARITIES OR LAPSES IN THIS DRAFT RED HERRING PROSPECTUS.**

#### **Disclaimer from our Company, the Selling Shareholders and the BRLMs**

Our Company, the Directors, the Selling Shareholders and the BRLMs accept no responsibility for statements made otherwise than in this Draft Red Herring Prospectus or in the advertisements or any other material issued by or at our Company's instance and anyone placing reliance on any other source of information, including our Company's website [www.unipartsgroup.com](http://www.unipartsgroup.com) or the respective websites of our Promoter Group or Group Company, would be doing so at his or her own risk.

The BRLMs accept no responsibility, save to the limited extent as provided in the Offer Agreement and the Underwriting Agreement to be entered into between the Underwriters, the Selling Shareholders and our Company.

All information shall be made available by our Company, the Selling Shareholders and the BRLMs to the public and investors at large and no selective or additional information would be available for a section of the investors in any manner whatsoever, including at road show presentations, in research or sales reports, at Bidding centres or elsewhere.

None among our Company, the Selling Shareholders or any member of the Syndicate is liable for any failure in downloading the Bids due to faults in any software/ hardware system or otherwise.

Investors who Bid in the Offer will be required to confirm and will be deemed to have represented to our Company, the Selling Shareholders, Underwriters and their respective directors, officers, agents, affiliates, and representatives that they are eligible under all applicable laws, rules, regulations, guidelines and approvals to acquire the Equity Shares and will not issue, sell, pledge, or transfer the Equity Shares to any person who is not eligible under any applicable laws, rules, regulations, guidelines and approvals to acquire the Equity Shares. Our Company, the Selling Shareholders, Underwriters and their respective directors, officers, agents, affiliates, and representatives accept no responsibility or liability for advising any investor on whether such investor is eligible to acquire the Equity Shares.

The BRLMs and their respective associates and affiliates may engage in transactions with, and perform services for, our Company, the Selling Shareholders and their respective group companies, affiliates or associates or third parties in the ordinary course of business and have engaged, or may in the future engage, in commercial banking and investment banking transactions with our Company, the Selling Shareholders and their respective group companies, affiliates or associates or third parties, for which they have received, and may in the future receive, compensation.

#### **Disclaimer in respect of Jurisdiction**

Any dispute arising out of the Offer will be subject to the jurisdiction of appropriate court(s) in New Delhi only.

The Offer is being made in India to persons resident in India (including Indian nationals resident in India who are competent to contract under the Indian Contract Act, 1872, HUFs, companies, corporate bodies and societies registered under the applicable laws in India and authorised to invest in shares, Indian Mutual Funds registered with the SEBI, Indian financial institutions, commercial banks, regional rural banks, co-operative banks (subject to RBI permission), or trusts under applicable trust law and who are authorised under their constitution to hold and invest in shares, permitted insurance companies and pension funds, insurance funds set up and managed by the army and navy and insurance funds set up and managed by the Department of Posts, India) and permitted Non-Residents including FPIs and Eligible NRIs, AIFs and other eligible foreign investors, if any, provided that they are eligible under all applicable laws and regulations to purchase the Equity Shares.

This Draft Red Herring Prospectus does not constitute an invitation to subscribe to or purchase the Equity Shares in the Offer in any jurisdiction, including India. Invitations to subscribe to or purchase the Equity Shares in the Offer will be made only pursuant to the Red Herring Prospectus if the recipient is in India or the preliminary offering memorandum for the Offer, which comprises the Red Herring Prospectus and the preliminary international wrap for the Offer, if the recipient is outside India. **No person outside India is eligible to bid for Equity Shares in the Offer unless that person has received the preliminary offering memorandum for the Offer, which contains the selling restrictions for the Offer outside India.**

The Equity Shares offered in the Offer have not been and will not be registered, listed or otherwise qualified in any jurisdiction except India and may not be offered or sold to persons outside of India except in compliance with the applicable laws of each such jurisdiction. In particular, the Equity Shares have not been and will not be registered under the U.S. Securities Act of 1933, as amended (the “**U.S. Securities Act**”), or the laws of any state of the United States and may not be offered or sold in the United States (as defined in Regulation S under the U.S. Securities Act (“**Regulation S**”)) except pursuant to an exemption from, or in a transaction not subject to, the registration requirements of the U.S. Securities Act and applicable state securities laws. The Equity Shares are being offered and sold only outside the United States pursuant to Regulation S.

**Each purchaser of the Equity Shares in the Offer in India shall be deemed to:**

- Represent and warrant to our Company, the Selling Shareholders, the BRLMs and the Syndicate Members that it was outside the United States (as defined in Regulation S) at the time the offer of the Equity Shares was made to it and it was outside the United States (as defined in Regulation S) when its buy order for the Equity Shares was originated.
- Represent and warrant to our Company, the Selling Shareholders, the BRLMs and the Syndicate Members that it did not purchase the Equity Shares as result of any “directed selling efforts” (as defined in Regulation S).
- Represent and warrant to our Company, the Selling Shareholders, the BRLMs and the Syndicate Members that it bought the Equity Shares for investment purposes and not with a view to the distribution thereof. If in the future it decides to resell or otherwise transfer any of the Equity Shares, it agrees that it will not offer, sell or otherwise transfer the Equity Shares except in a transaction complying with Rule 903 or Rule 904 of Regulation S or pursuant to any other available exemption from registration under the U.S. Securities Act.
- Represent and warrant to our Company, the Selling Shareholders, the BRLMs and the Syndicate Members that if it acquired any of the Equity Shares as fiduciary or agent for one or more investor accounts, it has sole investment discretion with respect to each such account and that it has full power to make the foregoing representations, warranties, acknowledgements and agreements on behalf of each such account.
- Represents and warrant to our Company, the Selling Shareholders, the BRLMs and the Syndicate Members that if it acquired any of the Equity Shares for one or more managed accounts, that it was authorized in writing by each such managed account to subscribe to the Equity Shares for each managed account and to make (and it hereby makes) the representations, warranties, acknowledgements and agreements herein for and on behalf of each such account, reading the reference to “it” to include such accounts.
- Agree to indemnify and hold the Company, the Selling Shareholders, the BRLMs and the Syndicate Members harmless from any and all costs, claims, liabilities and expenses (including legal fees and expenses) arising out of or in connection with any breach of these representations, warranties or agreements. It agrees that the indemnity set forth in this paragraph shall survive the resale of the Equity Shares.
- Acknowledge that our Company, the Selling Shareholders, the BRLMs, the Syndicate Members and others will rely upon the truth and accuracy of the foregoing representations, warranties, acknowledgements and agreements.

**Bidders are advised to ensure that any Bid from them does not exceed investment limits or maximum number of Equity Shares that can be held by them under applicable law.**

### **Disclaimer Clause of BSE**

As required, a copy of this Draft Red Herring Prospectus has been submitted to BSE. The disclaimer clause as intimated by BSE to our Company, post scrutiny of this Draft Red Herring Prospectus, shall be included in the Red Herring Prospectus and the Prospectus prior to the RoC filing.

### **Disclaimer Clause of the NSE**

As required, a copy of this Draft Red Herring Prospectus has been submitted to NSE. The disclaimer clause as intimated by NSE to our Company, post scrutiny of this Draft Red Herring Prospectus, shall be included in the Red Herring Prospectus and the Prospectus prior to the RoC filing.

### **Listing**

[●] will be the Designated Stock Exchange with which the Basis of Allotment will be finalised. Applications have been made to the BSE and NSE for permission to deal in and for an official quotation of the Equity Shares.

### **Consents**

Consents in writing of the Selling Shareholders, our Directors, our Company Secretary and Compliance Officer, Statutory Auditors, Indian Legal Counsel to our Company, Legal Counsel to the Investor Selling Shareholders, Indian Legal Counsel to the BRLMs, Bankers to our Company, the BRLMs, the Registrar to the Offer, CRISIL Research, Frost & Sullivan, independent chartered accountant and architect, and a third party chartered engineer have been obtained; and consents in writing of the Syndicate Members, Escrow Collection Bank(s) and Refund Bank(s) to act in their respective capacities, will be obtained and filed along with a copy of the Red Herring Prospectus with the RoC as required under the Companies Act and such consents shall not be withdrawn up to the time of delivery of the Red Herring Prospectus for registration with the RoC.

### **Expert to the Offer**

Except as stated below, our Company has not obtained any expert opinions:

Our Company has received written consent from the Statutory Auditors namely, Rakesh Banwari & Co., Chartered Accountants, holding a valid peer review certificate from ICAI, to include their name as required under Section 26 of the Companies Act, 2013 in this Draft Red Herring Prospectus and as an 'expert' as defined under Section 2(38) of Companies Act, 2013 in relation to the report dated November 23, 2018 on the Restated Financial Statements, and the statement of tax benefits dated November 23, 2018 included in this Draft Red Herring Prospectus. Such consent has not been withdrawn up to the time of delivery of this Draft Red Herring Prospectus.

### **Particulars regarding public or rights issues by our Company during the last five years**

Our Company has not made any public or rights issues during the five years preceding the date of this Draft Red Herring Prospectus.

### **Underwriting Commission, Brokerage and Selling Commission paid on previous issues of the Equity Shares**

Since this is the initial public issue of Equity Shares, no sum has been paid or is payable as commission or brokerage for subscribing to or procuring or agreeing to procure subscription for any of the Equity Shares in the five years preceding the date of this Draft Red Herring Prospectus.

### **Capital issue during the previous three years by our Company and the listed Group Company and the Subsidiaries of our Company**

Our Company has not undertaken a capital issue in the last three years preceding the date of this Draft Red Herring Prospectus.

None of our Subsidiaries or our Group Company are listed on any stock exchange.

### **Performance vis-à-vis objects – Public/ rights issue of our Company**

Our Company has not undertaken any public or rights issue in the five years preceding the date of this Draft Red Herring Prospectus.

### **Performance vis-à-vis objects – Public/ rights issue of the listed Subsidiaries of our Company**

None of our Subsidiaries are listed on any stock exchange.

**Price information of past issues handled by the BRLMs (during the current Fiscal and two Fiscals preceding the current Fiscal)**

**A. Axis Capital Limited**

1. Price information of past issues (during current financial year and two financial years preceding the current financial year) handled by Axis Capital Limited

Sr. No.	Issue name	Issue size (₹ millions)	Issue price (₹)	Listing date	Opening price on listing date (in ₹)	+/- % change in closing price, [+/- % change in closing benchmark]- 30th calendar days from listing	+/- % change in closing price, [+/- % change in closing benchmark]- 90th calendar days from listing	+/- % change in closing price, [+/- % change in closing benchmark]- 180th calendar days from listing
1	Ircon International Limited	4,667.03	475.00*	28-Sep-18	412.00	-27.04%, [-8.24%]	-	-
2	HDFC Asset Management Company Limited	28,003.31	1,100	06-Aug-18	1,726.25	+57.43%, [+1.17%]	+30.61%, [-7.32%]	-
3	Sandhar Technologies Limited	5,124.80	332.00	02-Apr-18	346.10	+18.09%, [+5.17%]	+15.95%, [+4.92%]	-4.20%, [+7.04%]
4	Hindustan Aeronautics Limited	41,131.33	1,215.00 <sup>!</sup>	28-Mar-18	1,152.00	-6.96%, [4.98%]	-25.84%, [+6.41%]	-25.45%, [+10.18%]
5	Bandhan Bank Limited	44,730.19	375.00	27-Mar-18	499.00	+31.81%, [3.79%]	+42.96%, [+6.26%]	+51.89%, [+9.42%]
6	Aster DM Healthcare Limited	9801.00	190.00	26-Feb-18	183.00	-13.66%, [-3.77%]	-4.97%, [+0.21%]	-8.16%, [+9.21%]
7	Khadim India Limited	5,430.57	750.00	14-Nov-17	730.00	-10.40%, [+0.06%]	-6.70%, [+2.63%]	+8.77%, [+6.09%]
8	The New India Assurance Company Limited	18,933.96	800 <sup>§</sup>	13-Nov-17	750.00	-27.91%, [+0.15%]	-12.93%, [+2.25%]	-13.06%, [+5.69%]
9	Mahindra Logistics Limited	8,288.84	429 <sup>^</sup>	10-Nov-17	429.00	+3.12%, [-0.54%]	+9.48%, [+1.50%]	+21.00%, [+3.84%]
10	Reliance Nippon Life Asset Management Limited	15,422.40	252	06-Nov-17	295.90	+3.61%, [-3.19%]	+5.91%, [+2.95%]	-4.21, [+1.59%]

Source: [www.nseindia.com](http://www.nseindia.com)

\* Offer Price was 465.00 per equity share to Retail Individual Bidders and Eligible Employees

<sup>^</sup> Offer Price was ₹ 387.00 per equity share to Eligible Employees

<sup>§</sup> Offer Price was ₹ 770.00 per equity share to Retail Individual Bidders and Eligible Employees

<sup>!</sup> Offer Price was ₹1,190.00 per equity share to Retail Individual Bidders and Eligible Employees

**Notes:**

1. Issue Size derived from Prospectus/final post issue reports, as available.
2. The CNX NIFTY is considered as the Benchmark Index.
3. Price on NSE is considered for all of the above calculations.
4. In case 30th/90th/180th day is not a trading day, closing price on NSE of the previous trading day has been considered.
5. Since 30 calendar days, 90 calendar days and 180 calendar days, as applicable, from listing date has not elapsed for few of the above issues, data for same is not available.

2. Summary statement of price information (during current financial year and two financial years preceding the current financial year) of past issues handled by Axis Capital Limited

Financial Year	Total no. of IPOs	Total funds raised (₹ in Millions)	Nos. of IPOs trading at discount on as on 30th calendar days from listing date			Nos. of IPOs trading at premium on as on 30th calendar days from listing date			Nos. of IPOs trading at discount as on 180th calendar days from listing date			Nos. of IPOs trading at premium as on 180th calendar days from listing date		
			Over 50%	Between 25%-50%	Less than 25%	Over 50%	Between 25%-50%	Less than 25%	Over 50%	Between 25%-50%	Less than 25%	Over 50%	Between 25%-50%	Less than 25%
2018-2019*	3	37,795.13	-	1	-	1	-	1	-	-	1	-	-	-
2017-2018	18	492,662.22	-	1	9	1	3	4	-	2	7	4	2	3
2016-2017	10	111,252.85	-	-	1	4	2	3	-	-	-	7	1	2

\* The information is as on the date of the document.

The information for each of the financial years is based on issues listed during such financial year.

Note: Since 30 calendar days and 180 calendar days, as applicable, from listing date has not elapsed for few of the above issues, data for same is not available.

## B. Motilal Oswal Investment Advisors Limited

### 1. Price information of past issues handled by Motilal Oswal Investment Advisors Limited

S. No.	Issue Name	Issue size (in ₹ million)	Issue price (₹)	Listing date	Opening price on listing date (₹)	+/- % change in closing price, [+/- % change in closing benchmark]- 30 <sup>th</sup> calendar days from listing	+/- % change in closing price, [+/- % change in closing benchmark]- 90 <sup>th</sup> calendar days from listing	+/- % change in closing price, [+/- % change in closing benchmark]- 180 <sup>th</sup> calendar days from listing
1.	Indostar Capital Finance Limited	18,440.00	572.00	May 21, 2018	600.00	-1.92% [2.43%]	-16.28% [9.07%]	-39.97% [1.57%]
2.	MAS Financial Services Limited	4,600.42	459.00	October 18, 2017	660.00	28.45% [+0.71%]	35.80% [+4.79%]	31.55% [+3.11%]
3.	Dixon Technologies (India) Limited	5,992.79	1766.00	September 18, 2017	2,725.00	50.78% [+0.57%]	80.93% [+1.77%]	95.22% [+0.41%]
4.	AU Small Finance Bank Limited	19,125.14	358.00	July 10, 2017	530.00	53.60% [+1.40%]	71.80% [+2.14%]	95.38% [+8.06%]
5.	GTPL Hathway Limited	4,848.00	170.00	July 4, 2017	170.00	-13.32% [+4.16%]	-19.90% [+1.82%]	-2.94% [+9.54%]
6.	PSP Projects Limited	2,116.80	210.00	May 29, 2017	190.00	21.67% [-1.18%]	68.37% [+2.63%]	103.21% [+8.17%]
7.	Avenue Supermarts Limited	18,700.00	299.00	March 21, 2017	600.00	152.94% [+0.16%]	166.35% [+5.88%]	263.80% [+10.57%]
8.	BSE Limited	12,434.32	806.00	February 3, 2017	1,085.00	10.51% [+1.79%]	24.21% [+7.08%]	32.41% [+15.34%]
9.	S.P. Apparels Limited	2,391.20	268.00	August 12, 2016	275.00	27.33% [+2.24%]	17.09% [-0.54%]	51.94% [+1.11%]
10.	Parag Milk Foods Limited	7,505.37	215.00	May 19, 2016	217.50	17.07% [+4.97%]	48.67% [+11.04%]	38.93% [+6.59%]

Source: www.nseindia.com

#### Notes

1. The S&P CNX NIFTY is considered as the Benchmark Index.

2. Price on NSE is considered for all of the above calculations.

3. In the event any day falls on a holiday, the price/index of the immediately preceding working day has been considered.

4. In Parag Milk Foods Limited, the issue price to retail individual investor and employees was ₹ 203 per equity share after a discount of ₹ 12 per equity share. The Anchor Investor Offer price was ₹ 227 per equity share.

2. Summary statement of price information of past issues handled by Motilal Oswal Investment Advisors Limited

Fiscal	Total no. of IPOs	Total amount of funds raised (₹ Mn.)	No. of IPOs trading at discount - 30 <sup>th</sup> calendar days from listing			No. of IPOs trading at premium - 30 <sup>th</sup> calendar days from listing			No. of IPOs trading at discount - 180 <sup>th</sup> calendar days from listing			No. of IPOs trading at premium - 180 <sup>th</sup> calendar days from listing		
			Over 50%	Between 25-50%	Less than 25%	Over 50%	Between 25-50%	Less than 25%	Over 50%	Between 25-50%	Less than 25%	Over 50%	Between 25-50%	Less than 25%
2018-19*	1	18,440.00	-	-	1	-	-	-	-	1	-	-	-	-
2017-18	5	36,683.15	-	-	1	2	1	1	-	-	1	3	1	-
2016-17	4	41,000.89	-	-	-	1	1	2	-	-	-	2	2	-

Source: [www.nseindia.com](http://www.nseindia.com)

\* The information is as on the date of the document.

The information for each of the financial years is based on issues listed during such financial year.

C. **SBI Capital Markets Limited**

1. Price information of past issues handled by SBI Capital Markets Limited

Sr. No.	Issue Name	Issue Size (₹ Mn.)	Issue Price (₹)	Listing Date	Opening Price on Listing Date	+/- % change in closing price, [+/- % change in closing benchmark]- 30th calendar days from listing	+/- % change in closing price, [+/- % change in closing benchmark]- 90th calendar days from listing	+/- % change in closing price, [+/- % change in closing benchmark]- 180th calendar days from listing
1.	Ircon International Limited 4	4,667.03	475	September 28, 2018	412.00	-27.04% [-8.24%]	NA	NA
2.	RITES Limited 5	4,604.40	185	July 02, 2018	190.00	34.97% [+6.56%]	51.30% [+3.29%]	NA
3.	ICICI Securities Ltd	35,148.49	520	April 04, 2018	435.00	-27.93% [+5.44%]	-37.26% [+5.22%]	-46.17% [+8.69%]
4.	Mishra Dhatu Nigam Limited 6	4,328.96	90	April 04, 2018	87.00	67.89% [+5.44%]	40.44% [+5.22%]	26.39% [+8.69%]
5.	Hindustan Aeronautics Ltd 7	41,131.33	1,215	March 28, 2018	1,152.00	-6.96% [+4.98%]	-25.84% [+6.41%]	-28.24% [+8.44%]
6.	Bharat Dynamics Limited 8	9,527.88	428	March 23, 2018	370.00	-2.90% [+5.66%]	-9.78% [+7.74%]	-19.60% [+12.81%]
7.	H. G. Infra Engineering Limited	4,620.00	270	March 9, 2018	270.00	19.19% [+1.02%]	8.35% [+4.48%]	-12.81% [+12.65%]
8.	Amber Enterprises India Limited 9	5,995.99	859	January 30, 2018	1,175.00	27.15% [-5.04%]	24.98% [-3.23%]	10.68% [+2.07%]
9.	Reliance Nippon Life Asset Management Limited	15,422.40	252	November 06, 2017	295.90	3.61% [-3.19%]	5.91% [+2.95%]	-4.21% [+1.59%]
10.	SBI Life Insurance Company Limited 10	83,864.00	700	October 3, 2017	735.00	-7.56% [+5.89%]	-0.66% [+6.81%]	-2.30% [+3.57%]

Source: [www.nseindia.com](http://www.nseindia.com)

**Notes:**

1. The 30th, 90th and 180th calendar day computation includes the listing day. If either of the 30th, 90th or 180th calendar days is a trading holiday, the previous trading day is considered for the computation. We have taken the issue price to calculate the % change in closing price as on 30th, 90th and 180th day. We have taken the closing price of the applicable benchmark index as on the listing day to calculate the % change in closing price of the benchmark as on 30th, 90th and 180th day.
2. The Nifty 50 index is considered as the Benchmark Index
3. The number of Issues in Table-1 is restricted to 10
4. Retail Discount and Employee Discount of ₹ 10 per Equity Share to the Offer Price
5. Retail Discount and Employee Discount of ₹ 6 per Equity Share to the Offer Price
6. Retail Discount and Employee Discount of ₹ 3 per Equity Share to the Offer Price
7. Retail Discount and Employee Discount of ₹ 25 per Equity Share to the Offer Price
8. Retail Discount and Employee Discount of ₹ 10 per Equity Share to the Offer Price
9. Employee Discount of ₹ 85 per Equity Share to the Offer Price
10. Employee Discount of ₹ 68 per Equity Share to the Offer Price

2. Summary statement of disclosure price information of past issues during the current Fiscal and two Fiscals preceeding the current Fiscal handled by SBI Capital Markets Limited

Financial Year	Total no. of IPOs	Total amount of funds raised (₹ Mn.)	No. of IPOs trading at discount - 30 <sup>th</sup> calendar days from listing			No. of IPOs trading at premium - 30 <sup>th</sup> calendar days from listing			No. of IPOs trading at discount - 180 <sup>th</sup> calendar days from listing			No. of IPOs trading at premium - 180 <sup>th</sup> calendar days from listing		
			Over 50%	Between 25-50%	Less than 25%	Over 50%	Between 25-50%	Less than 25%	Over 50%	Between 25-50%	Less than 25%	Over 50%	Between 25-50%	Less than 25%
2018-19	2	9,271.43	-	1	-	-	1	-	-	-	-	-	-	-
2017-18	12	203,995.12	-	-	5	2	2	3	-	3	3	1	3	2
2016-17	7	1,29,691.00	-	-	3	1	1	2	-	1	1	2	2	1



## Track record of past issues handled by the BRLMs

For details regarding the track record of the BRLMs, as specified in Circular reference CIR/MIRSD/1/2012 dated January 10, 2012 issued by SEBI, please see the websites of the BRLMs as set forth in the table below:

S. No.	Name of the BRLMs	Website
1.	Axis Capital Limited	www.axiscapital.co.in
2.	Motilal Oswal Investment Advisors Limited	www.motilaloswalgroup.com
3.	SBI Capital Markets Limited	www.sbicaps.com

## Stock Market Data of Equity Shares

This being an initial public offer of the Equity Shares of our Company, the Equity Shares are not listed on any stock exchange and accordingly, no stock market data is available for the Equity Shares.

## Redressal of Investor Grievances

The agreement between the Registrar to the Offer, our Company and the Selling Shareholders provides for retention of records with the Registrar to the Offer for a period of at least eight years from the last date of dispatch of the letters of allotment and demat credit to enable the investors to approach the Registrar to the Offer for redressal of their grievances.

All grievances in relation to the Bidding process may be addressed to the Registrar to the Offer with a copy to the relevant Designated Intermediary to whom the Bid cum Application Form was submitted. The Bidder should give full details such as name of the sole or first Bidder, Bid cum Application Form number, Bidder DP ID, Client ID, PAN, date of the submission of Bid cum Application Form, address of the Bidder, number of the Equity Shares applied for and the name and address of the Designated Intermediary where the Bid cum Application Form was submitted by the Bidder.

Anchor Investors are required to address all grievances in relation to the Offer to the BRLMs.

Further, the Bidder shall also enclose a copy of the Acknowledgment Slip duly received from the concerned Designated Intermediary in addition to the information mentioned hereinabove.

The Registrar to the Offer shall obtain the required information from the SCSBs for addressing any clarifications or grievances of ASBA Bidders. Our Company, the BRLMs and the Registrar to the Offer accept no responsibility for errors, omissions, commission or any acts of SCSBs including any defaults in complying with its obligations under applicable SEBI ICDR Regulations. Investors can contact the Compliance Officer or the Registrar to the Offer in case of any pre-Offer or post-Offer related problems such as non-receipt of letters of Allotment, non-credit of allotted Equity Shares in the respective beneficiary account, non-receipt of refund intimations and non-receipt of funds by electronic mode.

The Company shall obtain authentication on the SCORES and comply with the SEBI circular (CIR/OIAE/1/2013) dated April 17, 2013 in relation to redressal of investor grievances through SCORES.

Our Company has also constituted a Stakeholders' Relationship Committee to review and redress the shareholders and investor grievances such as transfer of Equity Shares, non-recovery of balance payments, declared dividends, approve subdivision, consolidation, transfer and issue of duplicate shares.

Our Company has also appointed Mukesh Kumar, Company Secretary of our Company, as the Compliance Officer for the Offer. For details, see "General Information" beginning on page 57.

Our Company has not received any investor complaint during the three years preceding the date of this Draft Red Herring Prospectus.

Further, no investor complaint in relation to our Company is pending as on the date of this Draft Red Herring Prospectus.

Our Group Company and our Subsidiaries are not listed on any stock exchange.

## Disposal of Investor Grievances by our Company

Our Company estimates that the average time required by our Company or the Registrar to the Offer or the relevant Designated Intermediary, for the redressal of routine investor grievances shall be 10 Working Days from the date of receipt of the complaint. In case of non-routine complaints and complaints where external agencies are involved, our Company will seek to redress these complaints as expeditiously as possible.

## SECTION VII: OFFER INFORMATION

### TERMS OF THE OFFER

The Equity Shares being Allotted pursuant to this Offer shall be subject to the provisions of the Companies Act, SEBI ICDR Regulations, SEBI Listing Regulations, SCRA, SCRR, our Memorandum of Association and Articles of Association, the terms of the Red Herring Prospectus, the Prospectus, the Abridged Prospectus, Bid cum Application Form, any Revision Form, the CAN/Allotment Advice and other terms and conditions as may be incorporated in the Allotment Advice and other documents/certificates that may be executed in respect of the Offer. The Equity Shares shall also be subject to laws as applicable, guidelines, rules, notifications and regulations relating to the issue of capital and listing and trading of securities issued from time to time by SEBI, the Government of India, the Stock Exchanges, the RBI, RoC and/or other authorities, as in force on the date of the Offer and to the extent applicable or such other conditions as may be prescribed by the SEBI, the RBI, the Government of India, the Stock Exchanges, the RoC and/or any other authorities while granting its approval for the Offer.

The Equity Shares being Allotted pursuant to the Offer shall rank *pari-passu* in all respects with the existing Equity Shares including in respect of the right to receive dividend. The Allottees upon Allotment of Equity Shares under the Offer, will be entitled to dividend and other corporate benefits, if any, declared by our Company after the date of Allotment. For further details, see “*Main Provisions of Articles of Association*” beginning on page 287.

Our Company shall pay dividends, if declared, to the Shareholders in accordance with the provisions of the Companies Act, the Memorandum and Articles of Association and provisions of the SEBI Listing Regulations and any other guidelines or directions which may be issued by the Government in this regard. Dividends, if any, declared by our Company after the date of Allotment (pursuant to the transfer of Equity Shares from the Offer for Sale), will be payable to the Bidders who have been Allotted Equity Shares in the Offer, for the entire year, in accordance with applicable laws. For further details, in relation to dividends, see “*Dividend Policy*” and “*Main Provisions of the Articles of Association*” beginning on pages 161 and 287, respectively.

#### Face Value and Offer Price

The face value of each Equity Share is ₹ 10 and the Offer Price at the lower end of the Price Band is ₹ [●] per Equity Share and at the higher end of the Price Band is ₹ [●] per Equity Share. The Anchor Investor Offer Price is ₹ [●] per Equity Share.

The Price Band and the minimum Bid Lot size for the Offer will be decided by our Company and the Investor Selling Shareholders, in consultation with the BRLMs, and advertised in [●] editions of [●] an English national daily newspaper, [●] editions of [●], a Hindi national daily newspaper (Hindi also being the regional language of New Delhi, where our registered office is located), each with wide circulation, at least two Working Days prior to the Bid/Offer Opening Date and shall be made available to the Stock Exchanges for the purpose of uploading the same on their respective websites. The Price Band, along with the relevant financial ratios calculated at the Floor Price and at the Cap Price, shall be pre-filled in the Bid cum Application Forms available on the websites of the Stock Exchanges.

At any given point of time there shall be only one denomination of Equity Shares.

#### The Offer

The Offer comprises a Fresh Issue and an Offer for Sale by the Selling Shareholders.

Expenses for the Offer shall be shared amongst our Company and the Selling Shareholders in the manner specified in “*Objects of the Offer - Offer Expenses*” on page 79.

#### Rights of the Equity Shareholders

Subject to applicable laws, rules, regulations and guidelines and our Articles of Association, our Shareholders shall have the following rights:

- Right to receive dividends, if declared;
- Right to attend general meetings and exercise voting rights, unless prohibited by law;
- Right to vote on a poll either in person or by proxy and e-voting, in accordance with the provisions of the Companies Act;
- Right to receive offers for rights shares and be allotted bonus shares, if announced;
- Right to receive surplus on liquidation, subject to any statutory and preferential claim being satisfied;

- Right of free transferability of the Equity Shares, subject to applicable laws including any RBI rules and regulations; and
- Such other rights, as may be available to a shareholder of a listed public company under the Companies Act, the SEBI Listing Regulations, and our Memorandum of Association and Articles of Association.

For a detailed description of the main provisions of the Articles of Association of our Company relating to voting rights, dividend, forfeiture and lien, transfer, transmission and/or consolidation or splitting, see “*Main Provisions of Articles of Association*” beginning on page 287.

#### **Allotment only in Dematerialised Form**

Pursuant to Section 29 of the Companies Act, 2013 and the SEBI ICDR Regulations, the Equity Shares shall be allotted only in dematerialised form. As per the SEBI ICDR Regulations, the trading of the Equity Shares shall only be in dematerialised form. In this context, two agreements have been signed amongst our Company, the respective Depositories and the Registrar to the Offer:

- Agreement dated December 18, 2012 amongst NSDL, our Company and the Registrar to the Offer;
- Agreement dated August 25, 2014 amongst CDSL, our Company and the Registrar to the Offer.

#### **Market Lot and Trading Lot**

Since trading of the Equity Shares is in dematerialised form, the tradable lot is one Equity Share. Allotment in this Offer will be only in electronic form in multiples of one Equity Share subject to a minimum Allotment of [●] Equity Shares.

#### **Joint Holders**

Where two or more persons are registered as the holders of the Equity Shares, they will be deemed to hold such Equity Shares as joint tenants with benefits of survivorship.

#### **Nomination facility to investors**

In accordance with Section 72 of the Companies Act, 2013 and the rules made thereunder, the sole Bidder, or the first Bidder along with other joint Bidders, may nominate any one person in whom, in the event of the death of sole Bidder or in case of joint Bidders, death of all the Bidders, as the case may be, the Equity Shares Allotted, if any, shall vest. A person, being a nominee, entitled to the Equity Shares by reason of the death of the original holder(s), shall be entitled to the same advantages to which he or she would be entitled if he or she were the registered holder of the Equity Share(s). Where the nominee is a minor, the holder(s) may make a nomination to appoint, in the prescribed manner, any person to become entitled to equity share(s) in the event of his or her death during the minority. A nomination shall stand rescinded upon a sale/transfer/alienation of equity share(s) by the person nominating. A buyer will be entitled to make a fresh nomination in the manner prescribed. Fresh nomination can be made only on the prescribed form available on request at our Registered Office or to the registrar and transfer agent of our Company.

Any person who becomes a nominee by virtue of the provisions of Section 72 of the Companies Act, 2013 shall upon the production of such evidence as may be required by the Board, elect either:

- to register himself or herself as the holder of the Equity Shares; or
- to make such transfer of the Equity Shares, as the deceased holder could have made.

Further, the Board may at any time give notice requiring any nominee to choose either to be registered himself or herself or to transfer the Equity Shares, and if the notice is not complied with within a period of 90 days, the Board may thereafter withhold payment of all dividends, interests, bonuses or other moneys payable in respect of the Equity Shares, until the requirements of the notice have been complied with.

Since the Allotment of Equity Shares in the Offer will be made only in dematerialized mode there is no need to make a separate nomination with our Company. Nominations registered with respective Depository Participant of the Bidder would prevail. If the Bidder wants to change the nomination, they are requested to inform their respective Depository Participant.

#### **Withdrawal of the Offer**

Our Company and the Selling Shareholders, in consultation with the BRLMs, reserve the right not to proceed with the Offer after the Bid/Offer Opening Date but before the Allotment. In such an event, our Company would issue a public notice in the newspapers in which the pre-Offer advertisements were published, within two days of the Bid/Offer Closing Date or such other time as may be prescribed by SEBI, providing reasons for not proceeding with the Offer. The BRLMs, through the

Registrar to the Offer, shall notify the SCSBs to unblock the bank accounts of the ASBA Bidders within one Working Day from the date of receipt of such notification. Our Company shall also inform the same to the Stock Exchanges on which the Equity Shares are proposed to be listed.

Notwithstanding the foregoing, this Offer is also subject to obtaining (i) the final listing and trading approvals of the Stock Exchanges, which our Company shall apply for after Allotment; and (ii) the final RoC approval of the Prospectus after it is filed with the RoC. If our Company or the Selling Shareholders, in consultation with the Book Running Lead Managers withdraw the Offer after the Bid/Offer Closing Date and thereafter determine that they will proceed with public offering of the Equity Shares, our Company shall file a fresh draft red herring prospectus with SEBI and the Stock Exchanges.

### Bid/Offer Programme

<b>BID/OFFER OPENS ON</b>	[●]*
<b>BID/OFFER CLOSES ON</b>	[●]**

\* Our Company and the Investor Selling Shareholders may, in consultation with the BRLMs, consider participation by Anchor Investors. The Anchor Investor Bid/Offer Period shall be one Working Day prior to the Bid/Offer Opening Date in accordance with the SEBI ICDR Regulations

\*\* Our Company and the Investor Selling Shareholders may, in consultation with the BRLMs, consider closing the Bid/Offer Period for QIBs one Working Day prior to the Bid/Offer Closing Date in accordance with the SEBI ICDR Regulations

An indicative timetable in respect of the Offer is set out below:

Event	Indicative Date
Finalisation of Basis of Allotment with the Designated Stock Exchange	On or about [●]
Initiation of refunds (if any, for Anchor Investors)/unblocking of funds from ASBA Account	On or about [●]
Credit of Equity Shares to demat accounts of Allottees	On or about [●]
Commencement of trading of the Equity Shares on the Stock Exchanges	On or about [●]

**The above timetable is indicative and does not constitute any obligation on our Company or the Selling Shareholders or the BRLMs.**

Whilst our Company shall ensure that all steps for the completion of the necessary formalities for the listing and the commencement of trading of the Equity Shares on the Stock Exchanges are taken within six Working Days of the Bid/Offer Closing Date or such period as may be prescribed, with reasonable support and co-operation of Selling Shareholders, as may be required in respect of their respective Offered Shares, the timetable may change due to various factors, such as extension of the Bid/Offer Period by our Company and the Investor Selling Shareholders, revision of the Price Band or any delay in receiving the final listing and trading approval from the Stock Exchanges. The commencement of trading of the Equity Shares will be entirely at the discretion of the Stock Exchanges and in accordance with the applicable laws. Each of the Selling Shareholders, severally and not jointly, confirm that they shall extend such reasonable support and co-operation required by our Company and the BRLMs for completion of the necessary formalities for listing and commencement of trading of the Equity Shares at the Stock Exchanges within six Working Days from the Bid/Offer Closing Date or such other period as may be prescribed by SEBI.

### Submission of Bids (other than Bids from Anchor Investors):

Bid/Offer Period (except the Bid/Offer Closing Date)	
Submission and Revision in Bids	Only between 10.00 a.m. and 5.00 p.m. (Indian Standard Time (“IST”))
Bid/Offer Closing Date	
Submission and Revision in Bids	Only between 10.00 a.m. and 3.00 p.m. IST

### On the Bid/Offer Closing Date, the Bids shall be uploaded until:

- (i) 4.00 p.m. IST in case of Bids by QIBs and Non-Institutional Bidders, and
- (ii) until 5.00 p.m. IST or such extended time as permitted by the Stock Exchanges, in case of Bids by Retail Individual Bidders.

On Bid/Offer Closing Date, extension of time will be granted by Stock Exchanges only for uploading Bids received from Retail Individual Bidders after taking into account the total number of Bids received and as reported by the BRLMs to the Stock Exchanges.

**It is clarified that Bids not uploaded on the electronic bidding system or in respect of which the full Bid Amount is not blocked by SCSBs would be rejected.**

Due to limitation of time available for uploading the Bids on the Bid/Offer Closing Date, Bidders are advised to submit their Bids one day prior to the Bid/Offer Closing Date. Any time mentioned in this Draft Red Herring Prospectus is IST. Bidders are cautioned that, in the event a large number of Bids are received on the Bid/Offer Closing Date, some Bids may not get uploaded due to lack of sufficient time. Such Bids that cannot be uploaded will not be considered for allocation under this

Offer. Bids will be accepted only during Monday to Friday (excluding any public holiday). None among our Company, the Selling Shareholders or any member of the Syndicate is liable for any failure in uploading the Bids due to faults in any software/hardware system or otherwise.

Our Company and the Investor Selling Shareholders, in consultation with the BRLMs, reserve the right to revise the Price Band during the Bid/Offer Period. The revision in the Price Band shall not exceed 20% on either side, *i.e.* the Floor Price can move up or down to the extent of 20% of the Floor Price and the Cap Price will be revised accordingly. The Floor Price shall not be less than the face value of the Equity Shares.

**In case of revision in the Price Band, the Bid/Offer Period shall be extended for at least three additional Working Days after such revision, subject to the Bid/Offer Period not exceeding 10 Working Days. In cases of force majeure, banking strike or similar circumstances, our Company may, for reasons to be recorded in writing, extend the Bid / Offer Period for a minimum of three Working Days, subject to the Bid/ Offer Period not exceeding 10 Working Days. Any revision in Price Band, and the revised Bid/Offer Period, if applicable, shall be widely disseminated by notification to the Stock Exchanges, by issuing a press release and also by indicating the change on the websites of the BRLMs and at the terminals of the Syndicate Members and by intimation to the Designated Intermediaries.**

### **Minimum Subscription**

If our Company does not receive the minimum subscription of 90% of the Fresh Issue on the date of closure of the issue; or withdrawal of applications; or after technical rejections; or if the listing or trading permission is not obtained from the Stock Exchanges for the Equity Shares so offered under the offer document, our Company shall forthwith refund the entire subscription amount received. If there is a delay beyond the prescribed time, our Company shall pay interest prescribed under the Companies Act, 2013, the SEBI ICDR Regulations and applicable law.

In the event of under subscription in the Offer, the Equity Shares will be Allotted in the following order:

- (i) such number of Equity Shares will first be Allotted by the Company such that 90% of the Fresh Issue portion is subscribed;
- (ii) next, all the Equity Shares held by the Investor Selling Shareholders and offered for sale in the Offer for Sale will be Allotted;
- (iii) once Equity Shares have been Allotted as per (i) and (ii) above, such number of Equity Shares will be Allotted by the Company that the balance 10% of the Fresh Issue portion is also subscribed;
- (iv) next, the Equity Shares held by the Individual Selling Shareholders (other than Pamela Soni and Meher Soni) and offered by the Individual Selling Shareholders (other than Pamela Soni and Meher Soni) will be Allotted, in proportion to the number of Equity Shares offered by each of them; and
- (v) lastly, the Equity Shares offered by Pamela Soni and Meher Soni will be Allotted, in proportion to the number of Equity Shares offered by each of them.

The Selling Shareholders shall, severally and not jointly, reimburse, in proportion to their respective Offered Shares, any expenses and interest incurred by our Company on behalf of the Selling Shareholders for any delays in making refunds as required under the Companies Act and any other applicable law, provided that no Selling Shareholder shall be responsible or liable for payment of such expenses or interest, unless such delay is solely and directly attributable to an act or omission of such Selling Shareholder.

Further, in terms of Regulation 49(1) of the SEBI ICDR Regulations, our Company shall ensure that the number of Bidders to whom the Equity Shares will be Allotted will be not less than 1,000.

### **Arrangements for Disposal of Odd Lots**

There are no arrangements for disposal of odd lots.

### **Restrictions, if any on Transfer and Transmission of Equity Shares**

Except for the lock-in of the pre-Offer capital of our Company, Promoters' Contribution and the Anchor Investor lock-in as provided in "*Capital Structure*" beginning on page 64 and except as provided in our Articles of Association there are no restrictions on transfer of Equity Shares. Further, there are no restrictions on the transmission of shares/debentures and on their consolidation/splitting, except as provided in the Articles of Association. For details, see "*Main Provisions of the Articles of Association*" beginning on page 287.

## OFFER STRUCTURE

Offer of [●] Equity Shares for cash at price of ₹ [●] per Equity Share (including a premium of ₹ [●] per Equity Share) aggregating to ₹ [●] million comprising of a Fresh Issue of [●] Equity Shares aggregating up to ₹ 1,000 million by our Company and an Offer of Sale of 13,060,770 Equity Shares aggregating up to ₹ [●] million, comprising 2,154,192 Equity Shares by Ambadevi and 7,180,642 Equity Shares by Ashoka, and 177,378 Equity Shares by Andrew Warren Code and 16,366 Equity Shares by Bradley Lorenz Miller and 5,010 Equity Shares by Craig A Johnson and 57,420 Equity Shares by Dennis Francis DeDecker and 8,340 Equity Shares by Diana Lynn Craig and 177,378 Equity Shares by James Norman Hallene and 177,378 Equity Shares by Kevin John Code and 7,710 Equity Shares by Marc Christopher Dorau and 20,870 Equity Shares by Mark Louis Dawson and 10,440 Equity Shares by Mary Louise Arp and 1,444,280 Equity Shares by Meher Soni and 41,730 Equity Shares by Melvin Keith Gibbs and 826 Equity Shares by Misty Marie Garcia and 1,534,548 Equity Shares by Pamela Soni and 24,706 Equity Shares by Walter James Gruber and 21,556 Equity Shares by Wendy Reichard Hammen.

The face value of the Equity Shares is ₹10 each.

The Offer is being made through the Book Building Process.

Particulars	QIBs <sup>(1)</sup>	Non-Institutional Bidders	Retail Individual Bidders
Number of Equity Shares available for Allotment/ allocation* <sup>(2)</sup>	Not more than [●] Equity Shares	Not less than [●] Equity Shares available for allocation or Offer less allocation to QIB Bidders and Retail Individual Bidders	Not less than [●] Equity Shares available for allocation or Offer less allocation to QIB Bidders and Non-Institutional Bidders
Percentage of Offer Size available for Allotment/ allocation	Not more than 50% of the Offer size shall be allocated to QIB Bidders. However, up to 5% of the QIB Portion (excluding the Anchor Investor Portion) will be available for allocation proportionately to Mutual Funds only. Mutual Funds participating in the Mutual Fund Portion will also be eligible for allocation in the remaining balance QIB Portion. The unsubscribed portion in the Mutual Fund portion will be available to QIBs.	Not less than 15% of the Offer, or the Offer less allocation to QIB Bidders and Retail Individual Bidders.	Not less than 35% of the Offer, or the Offer less allocation to QIB Bidders and Non-Institutional Bidders
Basis of Allotment/ allocation if respective category is oversubscribed*	Proportionate as follows (excluding the Anchor Investor Portion): (a) Up to [●] Equity Shares shall be available for allocation on a proportionate basis to Mutual Funds only; and (b) [●] Equity Shares shall be Allotted on a proportionate basis to all QIBs, including Mutual Funds receiving allocation as per (a) above  Up to [●] Equity Shares may be allocated on a discretionary basis to Anchor Investors	Proportionate	The allotment to each Retail Individual Bidder shall not be less than the minimum Bid Lot, subject to availability of Equity Shares in the Retail Portion and the remaining available Equity Shares if any, shall be allotted on a proportionate basis. For details see, "Offer Procedure" beginning on page 277
Minimum Bid	Such number of Equity Shares in multiples of [●] Equity Shares, that the Bid Amount exceeds ₹200,000	Such number of Equity Shares that the Bid Amount exceeds ₹200,000 and in multiples of [●] Equity Shares thereafter	[●] Equity Shares and in multiples of [●] Equity Shares thereafter
Maximum Bid	Such number of Equity Shares in multiples of [●] Equity Shares not exceeding the size of the Offer, subject to applicable limits	Such number of Equity Shares in multiples of [●] Equity Shares not exceeding the size of the Offer, subject to applicable limits	Such number of Equity Shares in multiples of [●] Equity Shares so that the Bid Amount does not exceed ₹200,000
Bid Lot	[●] Equity Shares and in multiples of [●] Equity Shares thereafter		
Mode of allotment	Compulsorily in dematerialised form		
Allotment Lot	[●] Equity Shares and in multiples of one Equity Share thereafter		
Trading Lot	One Equity Share		
Who can apply <sup>(4)</sup>	Public financial institutions as specified in Section 2(72) of the Companies Act, 2013, scheduled commercial banks, Mutual Funds, FPIs other than Category III FPIs, VCFs, AIFs, FVCIs registered with SEBI, multilateral and bilateral development financial institutions, state industrial development	Resident Indian individuals, Eligible NRIs, HUFs (in the name of the karta), companies, corporate bodies, scientific institutions societies	Resident Indian individuals, Eligible NRIs and HUFs (in the name of the karta)

Particulars	QIBs <sup>(1)</sup>	Non-Institutional Bidders	Retail Individual Bidders
	corporation, insurance companies registered with IRDAI, provident funds (subject to applicable law) with minimum corpus of ₹250 million, pension funds with minimum corpus of ₹250 million, National Investment Fund set up by the Government of India, the insurance funds set up and managed by army, navy or air force of the Union of India, insurance funds set up and managed by the Department of Posts, India and Systemically Important Non-Banking Financial Companies.	and trusts, Category III FPIs	
Terms of Payment	<p><b>In case of Anchor Investors:</b> Full Bid Amount shall be payable by the Anchor Investors at the time of submission of their Bids<sup>(3)</sup></p> <p><b>In case of all other Bidders:</b> Full Bid Amount shall be blocked by the SCSBs in the bank account of the ASBA Bidder (other than Anchor Investors) that is specified in the ASBA Form at the time of submission of the ASBA Form</p>		

\* Assuming full subscription in the Offer

- <sup>(1)</sup> Our Company and the Investor Selling Shareholders, in consultation with the BRLMs, may allocate up to 60% of the QIB Category to Anchor Investors on a discretionary basis in accordance with the SEBI ICDR Regulations. One-third of the Anchor Investor Portion shall be reserved for domestic Mutual Funds, subject to valid Bids being received from domestic Mutual Funds at or above the price at which allocation is being made to other Anchor Investors.
- <sup>(2)</sup> Subject to valid Bids being received at or above the Offer Price. This Offer is being made in accordance with Rule 19(2)(b) of the SCRR and under the SEBI ICDR Regulations.
- <sup>(3)</sup> Full Bid Amount shall be payable by the Anchor Investors at the time of submission of the Anchor Investor Application Form, provided that any difference between the price at which Equity Shares are allocated to the Anchor Investors and the Anchor Investor Offer Price, shall be payable by the Anchor Investor Pay-in Date as mentioned in the CAN.
- <sup>(4)</sup> If the Bid is submitted in joint names, the Bid cum Application Form should contain only the name of the first Bidder whose name should also appear as the first holder of the depository account held in joint names. The signature of only the first Bidder would be required in the Bid cum Application Form and such first Bidder would be deemed to have signed on behalf of the joint holders. Bidders will be required to confirm and will be deemed to have represented to our Company, the Selling Shareholders, the Underwriters, their respective directors, officers, agents, affiliates and representatives that they are eligible under applicable law, rules, regulations, guidelines and approvals to acquire the Equity Shares.

Subject to valid Bids being received at or above the Offer Price, under-subscription, if any, in any category except the QIB Portion, would be allowed to be met with spill over from any other category or combination of categories at the discretion of our Company and the Selling Shareholders in consultation with the BRLMs and the Designated Stock Exchange.

## OFFER PROCEDURE

All Bidders should read the General Information Document for Investing in Public Issues prepared and issued in accordance with the circular (CIR/CFD/DIL/12/2013) dated October 23, 2013 notified by SEBI and updated pursuant to the circular CIR/CFD/POLICYCELL/11/2015 dated November 10, 2015, the circular SEBI/HO/CFD/DIL/CIR/P/2016/26 dated January 21, 2016 and circular SEBI/HO/CFD/DIL2/CIR/P/2018/138 dated November 1, 2018 (the “**General Information Document**”), which highlights the key rules, processes and procedures applicable to public issues in general in accordance with the provisions of the Companies Act, the SCRA, the SCRR and the SEBI ICDR Regulations. The General Information Document is available on the websites of the Stock Exchanges and the BRLMs. Please refer to the relevant provisions of the General Information Document which are applicable to the Offer.

Additionally, all Bidders may refer to the General Information Document for information in relation to (i) category of investors eligible to participate in the Offer; (ii) maximum and minimum Bid size; (iii) price discovery and allocation; (iv) payment Instructions for ASBA Bidders; (v) issuance of Confirmation of Allocation Note (“CAN”) and Allotment in the Offer; (vi) price discovery and allocation; (vii) general instructions (limited to instructions for completing the Bid cum Application Form); (viii) designated date; (ix) disposal of applications; (x) submission of Bid cum Application Form; (xi) other instructions (limited to joint bids in cases of individual, multiple bids and instances when an application would be rejected on technical grounds); (xii) applicable provisions of Companies Act, 2013 relating to punishment for fictitious applications; (xiii) mode of making refunds; and (xiv) interest in case of delay in Allotment or refund.

Our Company, the Selling Shareholders and the BRLMs do not accept any responsibility for the completeness and accuracy of the information stated in this section and are not liable for any amendment, modification or change in the applicable law which may occur after the date of this Draft Red Herring Prospectus. Bidders are advised to make their independent investigations and ensure that their Bids are submitted in accordance with applicable laws and do not exceed the investment limits or maximum number of the Equity Shares that can be held by them under applicable law or as specified in this Draft Red Herring Prospectus, the Red Herring Prospectus and the Prospectus.

### Book Building Procedure

The Offer is being made through the Book Building Process in accordance with Regulation 6(1) of the SEBI ICDR Regulations wherein not more than 50% of the Offer shall be available for allocation to QIBs on a proportionate basis, provided that our Company and the Investor Selling Shareholders in consultation with the BRLMs may allocate up to 60% of the QIB Category to Anchor Investors on a discretionary basis in accordance with the SEBI ICDR Regulations, of which one-third shall be reserved for domestic Mutual Funds, subject to valid Bids being received from them at or above the Anchor Investor Allocation Price. 5% of the net QIB Category (excluding the Anchor Investor Portion) shall be available for allocation on a proportionate basis to Mutual Funds only, and the remainder of the QIB Category shall be available for allocation on a proportionate basis to all QIB Bidders (other than Anchor Investors), including Mutual Funds, subject to valid Bids being received at or above the Offer Price. Further, not less than 15% of the Offer shall be available for allocation on a proportionate basis to Non-Institutional Bidders and not less than 35% of the Offer shall be available for allocation to Retail Individual Bidders in accordance with the SEBI ICDR Regulations, subject to valid Bids being received at or above the Offer Price.

Under-subscription, if any, in any category, except in the QIB Category, would be allowed to be met with spill over from any other category or combination of categories, at the discretion of our Company in consultation with the BRLMs and the Designated Stock Exchange.

The Equity Shares, on Allotment, shall be traded only in the dematerialized segment of the Stock Exchanges.

**Investors should note that the Equity Shares will be Allotted to all successful Bidders only in dematerialised form. The Bid cum Application Forms which do not have the details of the Bidders’ depository account, including DP ID, Client ID and PAN, shall be treated as incomplete and will be rejected. Bidders will not have the option of being Allotted Equity Shares in physical form. However, they may get the Equity Shares rematerialised subsequent to Allotment of the Equity Shares in the IPO.**

### Phased implementation of Unified Payments Interface

SEBI has issued a circular (SEBI/HO/CFD/DIL2/CIR/P/2018/138) dated November 1, 2018 in relation to streamlining the process of public issue of inter alia, equity shares. Pursuant to the circular, Unified Payments Interface will be introduced in a phased manner as a payment mechanism in addition to ASBA for applications by Retail Individual Bidders through intermediaries. Phase I of this mechanism will be applicable from January 1, 2019.

### Bid cum Application Form



Copies of the ASBA Form and the abridged prospectus will be available with the Designated Intermediaries at the Bidding Centers, and the Registered Office. An electronic copy of the ASBA Form will also be available for download on the websites of NSE (www.nseindia.com) and BSE (www.bseindia.com) at least one day prior to the Bid/Offer Opening Date.

All Bidders (other than Anchor Investors) shall mandatorily participate in the Offer only through the ASBA process. ASBA Bidders must provide bank account details and authorisation to block funds in the relevant space provided in the ASBA Form and the ASBA Forms that do not contain such details will be rejected.

ASBA Bidders shall ensure that the Bids are made on ASBA Forms bearing the stamp of the Designated Intermediary, submitted at the Bidding Centers only (except in case of electronic ASBA Forms) and the ASBA Forms not bearing such specified stamp are liable to be rejected.

For Anchor Investors, the Anchor Investor Application Form will be available at the offices of the BRLMs.

The prescribed colour of the Bid cum Application Form for the various categories is as follows:

Category	Colour of Bid cum Application Form*
Resident Indians, including resident QIBs, Non-Institutional Investors, Retail Individual Bidders and Eligible NRIs applying on a non-repatriation basis	[●]
Eligible NRIs, FVCIs, FPIs and registered bilateral and multilateral institutions applying on a repatriation basis	[●]
Anchor Investors	[●]

\* Excluding electronic Bid cum Application Forms

Designated Intermediaries (other than SCSBs) shall submit/deliver the ASBA Forms to the respective SCSB, where the Bidder has a bank account with ASBA facility, details of which were provided by the Bidder in his respective ASBA form and shall not submit it to any non-SCSB bank or any Escrow Collection Bank.

#### **Participation by Promoters and Promoter Group of our Company, the BRLMs and the Syndicate Members**

The BRLMs and the Syndicate Members shall not be allowed to purchase Equity Shares in this Offer in any manner, except towards fulfilling their underwriting obligations. However, the associates and affiliates of the BRLMs and the Syndicate Members may Bid for Equity Shares in the Offer, either in the QIB Category or in the Non-Institutional Category as may be applicable to such Bidders, where the allocation is on a proportionate basis and such subscription may be on their own account or on behalf of their clients. All categories of investors, including associates or affiliates of the BRLMs and Syndicate Members, shall be treated equally for the purpose of allocation to be made on a proportionate basis.

Neither the BRLMs nor any persons related to the BRLMs (other than Mutual Funds sponsored by entities related to the BRLMs), Promoters and Promoter Group can apply in the Offer under the Anchor Investor Portion.

#### **Bids by Mutual Funds**

With respect to Bids by Mutual Funds, a certified copy of their SEBI registration certificate must be lodged along with the Bid cum Application Form. Failing this, our Company and the Investor Selling Shareholders reserve the right to reject any Bid without assigning any reason thereof.

Bids made by asset management companies or custodians of Mutual Funds shall specifically state names of the concerned schemes for which such Bids are made.

In case of a Mutual Fund, a separate Bid can be made in respect of each scheme of the Mutual Fund registered with SEBI and such Bids in respect of more than one scheme of the Mutual Fund will not be treated as multiple Bids provided that the Bids clearly indicate the scheme concerned for which the Bid has been made.

No Mutual Fund scheme shall invest more than 10% of its net asset value in equity shares or equity related instruments of any single company provided that the limit of 10% shall not be applicable for investments in case of index funds or sector or industry specific schemes. No Mutual Fund under all its schemes should own more than 10% of any company's paid-up share capital carrying voting rights.

#### **Bids by Eligible NRIs**

Eligible NRIs may obtain copies of Bid cum Application Form from the Designated Intermediaries. Eligible NRI Bidders bidding on a repatriation basis by using the Non-Resident Forms should authorize their SCSB to block their Non-Resident External ("NRE") accounts, or Foreign Currency Non-Resident ("FCNR") Accounts, and eligible NRI Bidders bidding on a non-repatriation basis by using Resident Forms should authorize their SCSB to block their Non-Resident Ordinary ("NRO") accounts for the full Bid Amount, at the time of the submission of the Bid cum Application Form.

Eligible NRIs Bidding on non-repatriation basis are advised to use the Bid cum Application Form for residents ([●] in colour). Eligible NRIs Bidding on a repatriation basis are advised to use the Bid cum Application Form meant for Non-Residents ([●] in colour).

### **Bids by HUFs**

Hindu Undivided Families or HUFs, in the individual name of the *Karta*. The Bidder/Applicant should specify that the Bid is being made in the name of the HUF in the Bid cum Application Form/Application Form as follows: "Name of sole or first Bidder/Applicant: XYZ Hindu Undivided Family applying through XYZ, where XYZ is the name of the *Karta*". Bids/Applications by HUFs may be considered at par with Bids/Applications from individuals;

### **Bids by FPIs**

In terms of the SEBI FPI Regulations, the issue of Equity Shares to a single FPI or an investor group (which means the same set of ultimate beneficial owner(s) investing through multiple entities) must be below 10% of our post-Offer Equity Share capital. Further, in terms of the FEMA Regulations, the total holding by each FPI shall be below 10% of the total paid-up Equity Share capital of our Company and the total holdings of all FPIs put together shall not exceed 24% of the paid-up Equity Share capital of our Company. In case the total holding of an FPI increases beyond 10% of the total paid-up equity capital of our Company, on a fully diluted basis or 10% or more of the paid-up value of any series of debentures or preference shares or share warrants issued that may be issued by our Company, the total investment made by the FPI will be re-classified as FDI subject to the conditions as specified by SEBI and the RBI in this regard and our Company and the investor will be required to comply with applicable reporting requirements.

In case the total holding of an FPI increases beyond 10% of the total paid-up Equity Share capital of our Company, on a fully diluted basis or 10% or more of the paid-up value of any series of debentures or preference shares or share warrants issued that may be issued by our Company, the total investment made by the FPI will be re-classified as FDI subject to the conditions as specified by SEBI and the RBI in this regard and our Company and the investor will be required to comply with applicable reporting requirements.

The aggregate limit of 24% may be increased up to the sectoral cap by way of a resolution passed by the Board followed by a special resolution passed by the Shareholders of our Company and subject to prior intimation to RBI. In terms of the FEMA Regulations, for calculating the aggregate holding of FPIs in a company, holding of all registered FPIs shall be included.

By a resolution of our Board dated November 23, 2018 and a resolution of our Shareholders dated November 27, 2018, our Company has increased the aggregate limits of its shareholding by FPIs to 100%. We have intimated the increase of these limits to the RBI.

FPIs are permitted to participate in the Offer subject to compliance with conditions and restrictions which may be specified by the Government from time to time.

Subject to compliance with all applicable Indian laws, rules, regulations, guidelines and approvals in terms of Regulation 22 of the SEBI FPI Regulations, an FPI, other than Category III foreign portfolio investor and unregulated broad based funds, which are classified as Category II foreign portfolio investor by virtue of their investment manager being appropriately regulated, may issue, subscribe to or otherwise deal in offshore derivative instruments (as defined under the SEBI FPI Regulations as any instrument, by whatever name called, which is issued overseas by a FPI against securities held by it that are listed or proposed to be listed on any recognised stock exchange in India, as its underlying) directly or indirectly, only in the event (i) such offshore derivative instruments are issued only to persons who are regulated by an appropriate regulatory authority; and (ii) such offshore derivative instruments are issued after compliance with 'know your client' norms. An FPI is also required to ensure that no further issue or transfer of any offshore derivative instrument is made by or on behalf of it to any persons that are not regulated by an appropriate foreign regulatory authority.

An FPI is also required to ensure that any transfer of offshore derivative instrument is made by, or on behalf of it subject to the following conditions:

- (a) offshore derivative instruments are transferred to persons subject to fulfilment of SEBI FPI Regulations; and
- (b) prior consent of the FPI is obtained for such transfer, except when the persons to whom the offshore derivative instruments are to be transferred to are pre-approved by the FPI.

### **Bids by SEBI registered VCFs, AIFs and FVCIs**

The SEBI FVCI Regulations and the SEBI AIF Regulations *inter-alia* prescribe the investment restrictions on the VCFs, FVCIs and AIFs registered with SEBI.

The holding by any individual VCF or FVCI registered with SEBI in one venture capital undertaking should not exceed 25% of the corpus of the VCF or FVCI. Further, VCFs and FVCIs can invest only up to 33.33% of the investible funds by way of subscription to an initial public offering.

The category I and II AIFs cannot invest more than 25% of the corpus in one investee company. A category III AIF cannot invest more than 10% of the corpus in one investee company. A venture capital fund registered as a category I AIF, as defined in the SEBI AIF Regulations, cannot invest more than 1/3<sup>rd</sup> of its corpus by way of subscription to an initial public offering of a venture capital undertaking. Additionally, the VCFs which have not re-registered as an AIF under the SEBI AIF Regulations shall continue to be regulated by the VCF Regulation until the existing fund or scheme managed by the fund is wound up.

**All non-resident investors should note that refunds (in case of Anchor Investors), dividends and other distributions, if any, will be payable in Indian Rupees only and net of bank charges and commission.**

Our Company, the Selling Shareholders or the BRLMs will not be responsible for loss, if any, incurred by the Bidder on account of conversion of foreign currency.

#### **Bids by limited liability partnerships**

In case of Bids made by limited liability partnerships registered under the Limited Liability Partnership Act, 2008, a certified copy of certificate of registration issued under the Limited Liability Partnership Act, 2008, must be attached to the Bid cum Application Form. Failing this, our Company and the Investor Selling Shareholders in consultation with the BRLMs reserves the right to reject any Bid without assigning any reason thereof.

#### **Bids by banking companies**

In case of Bids made by banking companies registered with RBI, certified copies of: (i) the certificate of registration issued by RBI, and (ii) the approval of such banking company's investment committee are required to be attached to the Bid cum Application Form, failing which our Company and the Investor Selling Shareholders in consultation with the BRLMs reserve the right to reject any Bid without assigning any reason.

The investment limit for banking companies in non-financial services companies as per the Banking Regulation Act, 1949, as amended (the "**Banking Regulation Act**"), and the Reserve Bank of India Master Direction (Financial Services provided by Banks) Directions, 2016, is 10% of the paid-up share capital of the investee company, not being its subsidiary engaged in non-financial services, or 10% of the banks' own paid-up share capital and reserves, whichever is less. Further, the aggregate investment by a banking company in subsidiaries and other entities engaged in financial and non-financial services company cannot exceed 20% of the bank's paid-up share capital and reserves. A banking company may hold up to 30% of the paid up share capital of the investee company with the prior approval of the RBI provided that the investee company is engaged in non-financial activities in which banking companies are permitted to engage under the Banking Regulation Act.

#### *Bids by SCSBs*

SCSBs participating in the Offer are required to comply with the terms of the SEBI circulars (Nos. CIR/CFD/DIL/12/2012 and CIR/CFD/DIL/1/2013) dated September 13, 2012 and January 2, 2013. Such SCSBs are required to ensure that for making applications on their own account using ASBA, they should have a separate account in their own name with any other SEBI registered SCSBs. Further, such account shall be used solely for the purpose of making application in public issues and clear demarcated funds should be available in such account for such applications.

#### **Bids by insurance companies**

In case of Bids made by insurance companies registered with the IRDAI, a certified copy of certificate of registration issued by IRDAI must be attached to the Bid cum Application Form. Failing this, our Company and the Investor Selling Shareholders in consultation with the BRLMs reserve the right to reject any Bid without assigning any reason thereof.

The exposure norms for insurers are prescribed under the Insurance Regulatory and Development Authority (Investment) Regulations, 2016, as amended ("**IRDAI Investment Regulations**"), based on investments in the equity shares of a company, the entire group of the investee company and the industry sector in which the investee company operates. Bidders are advised to refer to the IRDA Investment Regulations for specific investment limits applicable to them.

#### **Bids by provident funds/pension funds**

In case of Bids made by provident funds/pension funds, subject to applicable laws, with minimum corpus of ₹250 million, a certified copy of a certificate from a chartered accountant certifying the corpus of the provident fund/pension fund must be attached to the Bid cum Application Form. Failing this, our Company and the Investor Selling Shareholders in consultation with the BRLMs reserves the right to reject any Bid, without assigning any reason thereof.

## **Bids under Power of Attorney**

In case of Bids made pursuant to a power of attorney or by limited companies, corporate bodies, registered societies, Eligible FPIs, Mutual Funds, insurance companies, insurance funds set up by the army, navy or air force of the India, insurance funds set up by the Department of Posts, India or the National Investment Fund and provident funds with a minimum corpus of ₹250 million (subject to applicable law) and pension funds with a minimum corpus of ₹250 million, a certified copy of the power of attorney or the relevant resolution or authority, as the case may be, along with a certified copy of the memorandum of association and articles of association and/or bye laws must be lodged along with the Bid cum Application Form. Failing this, our Company and the Investor Selling Shareholders in consultation with the BRLMs reserves the right to accept or reject any Bid in whole or in part, in either case, without assigning any reason thereof.

Our Company and the Investor Selling Shareholders in consultation with the BRLMs in their absolute discretion, reserve the right to relax the above condition of simultaneous lodging of the power of attorney along with the Bid cum Application Form.

## **Bids by Systemically Important Non-Banking Financial Companies**

In case of Bids made by Systemically Important Non-Banking Financial Companies registered with RBI, certified copies of: (i) the certificate of registration issued by RBI, (ii) certified copy of its last audited financial statements on a standalone basis and a net worth certificate from its statutory auditor, and (iii) such other approval as may be required by the Systemically Important Non-Banking Financial Companies, are required to be attached to the Bid cum Application Form. Failing this, our Company and the Investor Selling Shareholder, in consultation with the BRLMs, reserves the right to reject any Bid without assigning any reason thereof. Systematically Important NBFCs participating in the Offer shall comply with all applicable regulations, guidelines and circulars issued by RBI from time to time.

The investment limit for Systemically Important NBFCs shall be as prescribed by RBI from time to time.

**The above information is given for the benefit of the Bidders. Our Company, the Selling Shareholders and the BRLMs are not liable for any amendments or modification or changes in applicable laws or regulations, which may occur after the date of this Draft Red Herring Prospectus. Bidders are advised to make their independent investigations and ensure that any single Bid from them does not exceed the applicable investment limits or maximum number of the Equity Shares that can be held by them under applicable law or regulation or as specified in this Draft Red Herring Prospectus, the Red Herring Prospectus and the Prospectus.**

## **General Instructions**

### ***Do's:***

1. Check if you are eligible to apply as per the terms of the Red Herring Prospectus and under applicable law, rules, regulations, guidelines and approvals. All Bidders (other than Anchor Investors) should submit their bids through the ASBA process only;
2. Ensure that you have Bid within the Price Band;
3. Read all the instructions carefully and complete the Bid cum Application Form in the prescribed form;
4. Ensure that you have mentioned the correct ASBA Account number in the Bid cum Application Form;
5. Ensure that your Bid cum Application Form bearing the stamp of a Designated Intermediary is submitted to the Designated Intermediary at the Bidding Center within the prescribed time;
6. Ensure that you have funds equal to the Bid Amount in the ASBA Account maintained with the SCSB before submitting the ASBA Form to any of the Designated Intermediaries;
7. If the first applicant is not the bank account holder, ensure that the Bid cum Application Form is signed by the account holder. Ensure that you have an account with an SCSB and have mentioned the correct bank account number in the Bid cum Application Form;
8. Ensure that the signature of the First Bidder in case of joint Bids, is included in the Bid cum Application Forms;
9. In case of joint Bids, the Bid cum Application Form should contain the name of only the First Bidder whose name should also appear as the first holder of the beneficiary account held in joint names;
10. Ensure that you request for and receive a stamped acknowledgement counterfoil of the Bid cum Application Form for all your Bid options from the concerned Designated Intermediary;

11. Ensure that the name(s) given in the Bid cum Application Form is / are exactly the same as the name(s) in which the beneficiary account is held with the Depository Participant. In case of joint Bids, the Bid cum Application Form should contain only the name of the First Bidder whose name should also appear as the first holder of the beneficiary account held in joint names. Ensure that the signature of the First Bidder is included in the Bid cum Application Forms;
12. Instruct your respective banks to release the funds blocked in accordance with the ASBA process;
13. Ensure that you submit the revised Bids to the same Designated Intermediary, through whom the original Bid was placed and obtain a revised acknowledgment;
14. Except for Bids (i) on behalf of the Central or State Governments and the officials appointed by the courts, who, in terms of the SEBI circular dated June 30, 2008, may be exempt from specifying their PAN for transacting in the securities market, (ii) submitted by investors who are exempt from the requirement of obtaining / specifying their PAN for transacting in the securities market, and (iii) Bids by persons resident in the state of Sikkim, who, in terms of a SEBI circular dated July 20, 2006, may be exempted from specifying their PAN for transacting in the securities market, all Bidders should mention their PAN allotted under the IT Act. The exemption for the Central or the State Government and officials appointed by the courts and for investors residing in the State of Sikkim is subject to (a) the Demographic Details received from the respective depositories confirming the exemption granted to the beneficiary owner by a suitable description in the PAN field and the beneficiary account remaining in "active status"; and (b) in the case of residents of Sikkim, the address as per the Demographic Details evidencing the same. All other applications in which PAN is not mentioned will be rejected;
15. Ensure that the Demographic Details are updated, true and correct in all respects;
16. Ensure that thumb impressions and signatures other than in the languages specified in the Eighth Schedule to the Constitution of India are attested by a Magistrate or a Notary Public or a Special Executive Magistrate under official seal;
17. Ensure that the category and the investor status is indicated;
18. Ensure that in case of Bids under power of attorney or by limited companies, corporates, trust, etc., relevant documents are submitted;
19. Ensure that Bids submitted by any person outside India is in compliance with applicable foreign and Indian laws;
20. Ensure that the Bidder's depository account is active, the correct DP ID, Client ID and the PAN are mentioned in their Bid cum Application Form and that the name of the Bidder, the DP ID, Client ID and the PAN entered into the online IPO system of the Stock Exchanges by the relevant Designated Intermediary, as applicable, matches with the name, DP ID, Client ID and PAN available in the Depository database; and
21. Ensure that you have correctly signed the authorisation/undertaking box in the Bid cum Application Form, or have otherwise provided an authorisation to the SCSB via the electronic mode, for blocking funds in the ASBA Account equivalent to the Bid Amount mentioned in the Bid cum Application Form at the time of submission of the Bid.

The Bid cum Application Form is liable to be rejected if the above instructions, as applicable, are not complied with.

***Don'ts:***

1. Do not Bid for lower than the minimum Bid size;
2. Do not Bid for a Bid Amount exceeding ₹200,000 (for Bids by Retail Individual Bidders);
3. Do not pay the Bid Amount in cheques, demand drafts or by cash, money order, postal order or by stock invest;
4. Do not send Bid cum Application Forms by post; instead submit the same to the Designated Intermediary only;
5. Do not Bid at Cut-off Price (for Bids by QIBs and Non-Institutional Bidders);
6. Do not instruct your respective banks to release the funds blocked in the ASBA Account under the ASBA process;
7. Do not submit the Bid for an amount more than funds available in your ASBA account.
8. Do not submit Bids on plain paper or on incomplete or illegible Bid cum Application Forms or on Bid cum Application Forms in a colour prescribed for another category of Bidder;

9. Do not submit more than five Bid cum Application Forms per ASBA account;
10. Anchor Investors should not Bid through the ASBA process;
11. Do not submit the Bid cum Application Forms to any non-SCSB bank or our Company;
12. Do not Bid on a Bid cum Application Form that does not have the stamp of the relevant Designated Intermediary;
13. Do not submit the General Index Register (GIR) number instead of the PAN;
12. Do not submit incorrect details of the DP ID, Client ID and PAN or provide details for a beneficiary account which is suspended or for which details cannot be verified by the Registrar to the Offer;
13. Do not submit a Bid in case you are not eligible to acquire Equity Shares under applicable law or your relevant constitutional documents or otherwise;
14. Do not Bid if you are not competent to contract under the Indian Contract Act, 1872 (other than minors having valid depository accounts as per Demographic Details provided by the depository).
15. Do not submit a Bid/revise a Bid Amount, with a price less than the Floor Price or higher than the Cap Price;
16. Do not Bid on another Bid cum Application Form and the Anchor Investor Application Form, as the case may be, after you have submitted a Bid to any of the Designated Intermediaries after you have submitted a Bid to the Designated Intermediary;
17. Do not Bid for shares more than specified by respective Stock Exchanges for each category;
18. Do not fill up the Bid cum Application Form such that the Equity Shares Bid for exceeds the Offer size and/or investment limit or maximum number of the Equity Shares that can be held under applicable laws or regulations or maximum amount permissible under applicable laws or regulations, or under the terms of the Red Herring Prospectus;
19. Do not withdraw your Bid or lower the size of your Bid (in terms of quantity of the Equity Shares or the Bid Amount) at any stage, if you are a QIB or a Non-Institutional Bidder. Retail Individual Bidders can revise their Bids during the Bid/Offer Period and withdraw their Bids on or before the Bid/Offer Closing Date; and
20. Do not submit Bids to a Designated Intermediary unless the SCSB where the ASBA Account is maintained, as specified in the Bid cum Application Form, has named at least one branch in that location for the Designated Intermediary to deposit the Bid cum Application Forms.

The Bid cum Application Form is liable to be rejected if the above instructions, as applicable, are not complied with.

Further, in case of any pre-issue or post issue related issues regarding share certificates/demat credit/refund orders/unblocking etc., investors shall reach out the company secretary and compliance officer. For details of company secretary and compliance officer, see “*General Information*” beginning on page 57.

#### **Names of entities responsible for finalising the basis of allotment in a fair and proper manner**

The authorised employees of the Stock Exchanges, along with the BRLMs and the Registrar, shall ensure that the Basis of Allotment is finalised in a fair and proper manner in accordance with the procedure specified in SEBI ICDR Regulations.

#### **Method of allotment as may be prescribed by SEBI from time to time**

Our Company will not make any allotment in excess of the Equity Shares offered through the Offer through the offer document except in case of oversubscription for the purpose of rounding off to make allotment, in consultation with the Designated Stock Exchange. Further, upon oversubscription, an allotment of not more than 1% of the net offer to public may be made for the purpose of making allotment in minimum lots.

The allotment of Equity Shares to applicants other than to the Retail Individual Investors and Anchor Investors shall be on a proportionate basis within the respective investor categories and the number of securities allotted shall be rounded off to the nearest integer, subject to minimum allotment being equal to the minimum application size as determined and disclosed.

The allotment of Equity Shares to each Retail Individual Investor shall not be less than the minimum bid lot, subject to the availability of shares in Retail Individual Investor category, and the remaining available shares, if any, shall be allotted on a proportionate basis.

## Payment into Escrow Account(s) for Anchor Investors

Our Company and the Investor Selling Shareholders in consultation with the BRLMs, in their absolute discretion, will decide the list of Anchor Investors to whom the CAN will be sent, pursuant to which the details of the Equity Shares allocated to them in their respective names will be notified to such Anchor Investors. For Anchor Investors, the payment instruments for payment into the Escrow Account(s) should be drawn in favour of:

- (a) In case of resident Anchor Investors: “[●]”
- (b) In case of Non-Resident Anchor Investors: “[●]”

Anchor Investors should note that the escrow mechanism is not prescribed by SEBI and has been established as an arrangement between our Company, the Selling Shareholders, the Syndicate, the Escrow Collection Bank and the Registrar to the Offer to facilitate collections of Bid amounts from Anchor Investors.

## Pre- Offer Advertisement

Subject to Section 30 of the Companies Act, 2013, our Company shall, after registering the Red Herring Prospectus with the RoC, publish a pre-Offer advertisement, in the form prescribed by the SEBI ICDR Regulations, in: (i) [●] editions of [●], a English national daily newspaper; and (ii) [●] editions of [●], a Hindi national daily newspaper [●] (Hindi also being the regional language of New Delhi, where our registered office is located) each with wide circulation.

In the pre-Offer advertisement, we shall state the Bid/Offer Opening Date and the Bid/Offer Closing Date. This advertisement, subject to the provisions of Section 30 of the Companies Act, 2013, shall be in the format prescribed in Part A of Schedule X of the SEBI ICDR Regulations.

**The above information is given for the benefit of the Bidders/applicants. Our Company, the Selling Shareholders and the members of the Syndicate are not liable for any amendments or modification or changes in applicable laws or regulations, which may occur after the date of this Draft Red Herring Prospectus. Bidders/applicants are advised to make their independent investigations and ensure that the number of Equity Shares Bid for do not exceed the prescribed limits under applicable laws or regulations.**

## Signing of the Underwriting Agreement and the RoC Filing

- (a) Our Company, the Selling Shareholders and the Syndicate intend to enter into an Underwriting Agreement after the finalisation of the Offer Price which shall be a date prior to the filing of Prospectus.
- (b) After signing the Underwriting Agreement, an updated Red Herring Prospectus will be filed with the RoC in accordance with applicable law, which then would be termed as the ‘Prospectus’. The Prospectus will contain details of the Offer Price, the Anchor Investor Offer Price, Offer size, and underwriting arrangements and will be complete in all material respects.

## Undertakings by our Company

Our Company undertakes the following:

- adequate arrangements shall be made to collect all Bid cum Application Forms submitted by Bidders;
- the complaints received in respect of the Offer shall be attended to by our Company expeditiously and satisfactorily;
- all steps for completion of the necessary formalities for listing and commencement of trading at all the Stock Exchanges where the Equity Shares are proposed to be listed shall be taken in consultation with the BRLMs within such period as may be prescribed under applicable law;
- if Allotment is not made within the prescribed time period under applicable law, the entire subscription amount received will be refunded/unblocked within the time prescribed under applicable law. If there is delay beyond the prescribed time, our Company shall pay interest prescribed under the Companies Act, 2013, the SEBI ICDR Regulations and applicable law for the delayed period;
- the funds required for making refunds (to the extent applicable) as per the mode(s) disclosed shall be made available to the Registrar to the Offer by our Company;
- where refunds (to the extent applicable) are made through electronic transfer of funds, a suitable communication shall be sent to the applicant within the time prescribed under applicable law, giving details of the bank where refunds shall be credited along with amount and expected date of electronic credit of refund;

- compliance with all disclosure and accounting norms as may be specified by SEBI from time to time;
- Promoters' contribution, if any, shall be brought in advance before the Bid/Offer Opening Date and the balance, if any, shall be brought in on a pro rata basis before calls are made on the Allottees; and
- except for any allotment of Equity Shares to employees of our Company pursuant to exercise of options granted under the Employee Scheme, no further issue of the Equity Shares shall be made till the Equity Shares offered through the Red Herring Prospectus are listed or until the Bid monies are unblocked in ASBA Account/refunded on account of non-listing, under-subscription, etc.

### **Undertakings by the Selling Shareholders**

Each Selling Shareholder undertakes severally and not jointly in respect of itself as a Selling Shareholder and its respective portion of the Equity Shares offered by it in the Offer for Sale that:

- the Equity Shares offered for sale by the Selling Shareholder in the Offer are eligible for being offered in the Offer for Sale in terms of Regulation 8 of the SEBI ICDR Regulations;
- the Equity Shares being offered for sale by the Selling Shareholder pursuant to the Offer are free and clear of any pre-emptive rights, liens, mortgages, charges, pledges or any other encumbrances and shall be in dematerialized form at the time of transfer;
- it shall deposit its Equity Shares offered for sale in the Offer in an escrow demat in accordance with the share escrow agreement to be executed between the parties to such share escrow agreement;
- that it shall provide such reasonable assistance to our Company and the BRLMs in redressal of such investor grievances that pertain to the Equity Shares held by it and being offered pursuant to the Offer;
- it shall provide such reasonable cooperation to our Company in relation to their respective portion of the Equity Shares offered by it in the Offer for Sale for the completion of the necessary formalities for listing and commencement of trading at the Stock Exchanges; and
- it shall not have recourse to the proceeds of the Offer until final approval for trading of the Equity Shares from the Stock Exchanges has been received.

The decisions with respect to the Price Band, the minimum Bid lot, revision of Price Band, Offer Price, will be taken by our Company and the Investor Selling Shareholders, in consultation with the BRLMs.

Only the statements and undertakings in relation to the Investor Selling Shareholder and the Individual Selling Shareholders and their portion of the Equity Shares offered in the Offer for Sale which are specifically "confirmed" or "undertaken" by the Investor Selling Shareholder and the Individual Selling Shareholders in this Draft Red Herring Prospectus, shall be deemed to be "statements and undertakings specifically confirmed or undertaken" by the Investor Selling Shareholder and the Individual Selling Shareholders. All other statements and/ or undertakings in this Draft Red Herring Prospectus shall be statements and undertakings made by our Company even if the same relate to the Investor Selling Shareholder and the Individual Selling Shareholders.

### **Utilisation of Offer Proceeds**

Our Board certifies that:

- all monies received out of the Fresh Issue shall be credited/transferred to a separate bank account other than the bank account referred to in sub-Section (3) of Section 40 of the Companies Act, 2013;
- details of all monies utilised out of the Offer shall be disclosed, and continue to be disclosed till the time any part of the Fresh Issue proceeds remains unutilised, under an appropriate head in the balance sheet of our Company indicating the purpose for which such monies have been utilised; and
- details of all unutilised monies out of the Fresh Issue, if any shall be disclosed under an appropriate separate head in the balance sheet indicating the form in which such unutilised monies have been invested. The Company, each of the Individual Selling Shareholders and the Investor Selling Shareholders, severally and not jointly, specifically confirm and declare that all monies received out of the Offer shall be transferred to a separate bank account other than the bank account referred to in sub-Section 3 of Section 40 of the Companies Act, 2013.



## RESTRICTIONS ON FOREIGN OWNERSHIP OF INDIAN SECURITIES

Foreign investment in Indian securities is regulated through the Industrial Policy, 1991 of the Government of India and FEMA. While the Industrial Policy, 1991 prescribes the limits and the conditions subject to which foreign investment can be made in different sectors of the Indian economy, FEMA regulates the precise manner in which such investment may be made. The Union Cabinet, as provided in the Cabinet Press Release dated May 24, 2017, has given its approval for phasing out the FIPB. Accordingly, the process for foreign direct investment (“**FDI**”) and approval from the Government of India will now be handled by the concerned ministries or departments, in consultation with the Department of Industrial Policy and Promotion, Ministry of Commerce and Industry, Government of India (“**DIPP**”), Ministry of Finance, Department of Economic Affairs, FIPB section, through a memorandum dated June 5, 2017 has notified the specific ministries handling relevant sectors.

The Government of India has from time to time made policy pronouncements on FDI through press notes and press releases. The DIPP issued the Consolidated Foreign Direct Investment Policy notified by the D/o IPP F. No. 5(1)/2017-FC-1 dated August 28, 2017, with effect from August 28, 2017 (the “**FDI Policy**”), which consolidates and supersedes all previous press notes, press releases and clarifications on FDI issued by the DIPP that were in force and effect prior to August 28, 2017. The Government of India proposes to update the consolidated circular on FDI Policy once every year and therefore, the FDI Policy will be valid until the DIPP issues an updated circular.

The transfer of shares between an Indian resident and a non-resident does not require the prior approval of the RBI, provided that (i) the activities of the investee company are under the automatic route under the foreign direct investment policy and transfer does not attract the provisions of the Takeover Regulations; (ii) the non-resident shareholding is within the sectoral limits under the FDI policy; and (iii) the pricing is in accordance with the guidelines prescribed by the SEBI/RBI.

As per the existing policy of the Government of India, OCBs cannot participate in this Offer.

For further details, see “*Offer Procedure*” beginning on page 277.

The above information is given for the benefit of the Bidders. Our Company, the Selling Shareholders and the BRLMs are not liable for any amendments or modification or changes in applicable laws or regulations, which may occur after the date of this Draft Red Herring Prospectus. Bidders are advised to make their independent investigations and ensure that the number of Equity Shares Bid for do not exceed the applicable limits under laws or regulations.

## SECTION VIII: MAIN PROVISIONS OF ARTICLES OF ASSOCIATION

*Capitalized terms used in this section have the meanings that have been given to such terms in the Articles of Association of our Company. Pursuant to Schedule I of the Companies Act, 2013 and the SEBI ICDR Regulations, the main provisions of the Articles of Association of our Company are detailed below:*

*The Articles of Association of Uniparts India Limited are divided into Parts I and II, which parts shall, unless the context otherwise requires, co-exist with each other. However, until commencement of listing and trading of the equity shares of our Company on BSE Limited and/or National Stock Exchange of India Limited pursuant to the initial public offering, in case of any inconsistency between Part I and Part II of these Articles, the provisions of Part II shall prevail.*

*Notwithstanding the foregoing or anything contained in these Articles, Part II shall stand automatically deleted and cease to have force and effect from the date on which the equity shares of our Company get listed and commence trading on BSE Limited and/or National Stock Exchange of India Limited following an initial public offering of the equity shares of our Company without the requirement of any further action by our Company or our shareholders.*

### PART I

#### Authorised Share Capital

The authorized share capital of the Company shall be such as given in Clause V of the Memorandum of Association or as altered from time to time, payable in the manner as may be determined by the Board, with the power to increase, reduce, sub-divide or to repay the same or to divide the same into several classes and to attach thereto any rights and to consolidate or sub-divide or re-organize the shares and subject to the provisions of the Companies Act, to vary such rights as may be determined in accordance with the regulations of the Company.

#### Alteration of Capital

Power to sub- divide and consolidate

The Company may, by ordinary resolution, from time to time, subject to Section 61 of the Companies Act, alter the conditions of Memorandum of Association as follows:

- a. Increase the share capital by such amount to be divided into shares of such amount as may be specified in the resolution;
- b. Consolidate and divide all or any its share capital into shares of larger amount than its existing shares;
- c. Sub- divide its existing shares or any of them into shares of smaller amount than is fixed by Memorandum of Association;
- d. Cancel any shares which, at the date of the passing of the resolution, have not been taken or agreed to be taken by any person; and
- e. Convert all or any one its fully paid-up shares into stock, and reconvert that stock into fully paid-up shares of any denomination.

#### Allotment of Shares

Subject to the provisions of the Companies Act and these Articles, the shares in the capital of the Company for the time being shall be under the control of the Board who may issue, allot or otherwise dispose of the same or any of them to such persons, in such proportion and on such terms and conditions and either at a premium or at par or at a discount and at such time as they may from time to time think fit and with the sanction of the Company in the general meeting to give to any person the option or right to call for any shares either at par or premium during such time and for such consideration as the Board think fit, and may issue and allot shares in the capital of the Company on payment in full or part of any property sold and transferred or for any services rendered to the Company for conducting of its business and any shares so allotted will be issued as fully paid up shares and if issued, shall be deemed to be fully paid shares. Provided that option or right to call of shares shall not be given to any person or persons without the sanction of the Company in the general meeting.

#### Forfeiture and Lien

The Company shall have a first and paramount lien upon all the shares/ debentures registered in the name of such member. If a member fails to pay any call, or installment on or before the day appointed for the payment of the same, the Board may at any time thereafter, during such time as the call or installment remain unpaid, serve notice on such member requiring him to pay the same together with any interest that may have accrued and expenses that may have been incurred by the Company by reasons of such non-payment.

### **Power to issue new certificate**

Where any shares under the powers in that behalf herein contained are sold by the Board and the certificate thereof has not been delivered to the Company by the former holders of the said shares the Board may issue new certificate in lieu of certificate not so delivered up.

### **Transfer of Shares**

A common form of transfer shall be used in case of transfer of shares. Save as provided in Section 56 of the Companies Act, no transfer of debenture shall be registered unless a proper instrument of transfer duly stamped and executed by the transferor and the transferee has been delivered to the Company together with the certificate or certificates of debentures. If the Board refuses to register the transfer of any debentures, the Company shall, within 30 (Thirty) days from the date on which the instrument of transfer was lodged with the Company, send to the transferee and to the transferor notice of the refusal. Subject to the provisions of the Companies Act and these Articles, no transfer of shares shall be registered unless a proper instrument of transfer duly stamped and executed by or on behalf of the transferor or transferee has been delivered to the Company within a period of 60 (Sixty) days from the date of the execution together with the certificate or certificates of the shares or if no such certificate is in existence along with the letter of allotment of shares.

### **Transmission of shares**

The executors or administrators or nominees or legal representatives or the holder of succession certificate in respect of shares of a deceased member (not being one of several joint holders) shall be the only person whom the Company shall recognize as having any title to the shares registered in the name of such member and, in case of the death of any one or more of the joint- holders of any registered shares the survivors shall be only persons recognized by the Company as having any title to or interest in such share but nothing herein contained shall be taken to release the estate of a deceased joint- holder from any liability on shares held by him jointly with any other person. Before recognizing any legal representative or heir or a person otherwise claiming title to the shares the Company may require him to obtain a grant of probate or letters of administration or succession certificate or other legal representation as the case may be from a competent court, provided nevertheless that in any case where the Board in its absolute discretion think fit, it shall be lawful for the Board to dispense with production of the probate or letter of administration or a secession certificate or such other legal representation upon such terms as to indemnity or otherwise as the Board may consider desirable.

### **Certificate**

Every certificate of shares shall be under the Seal of the Company and shall specify the number and distinctive numbers of shares in respect of which it is issued and amount paid-up thereon and shall be in such form as the Board may prescribe or approve, provided that in respect of a share or shares held jointly by several persons, the Company shall not be bound to issue more than one certificate and delivery of a certificate of shares to one of several joint holders shall be sufficient delivery vis-à-vis all such holders. Particulars of every certificate issued shall be entered in the register maintained in the form set out in the Companies Act.

If any certificate of any shares or shares be surrendered to the Company for sub-division or consolidation or if any certificate be defaced, mutilated, torn or old, decrepit, worn- out or where the pages on the reverse for recording transfer have been duly utilized, then upon production and surrender thereof to the Company, the Board may order the same to be cancelled and may issue new certificate in lieu thereof and if any certificate be lost or destroyed then upon proof thereof to the satisfaction of the Company and on such indemnity as the Company think adequate being given a new certificate in lieu thereof shall be given to a party entitled to the shares of such lost or destroyed certificate relates. Where a new certificate has been issued as aforesaid it shall state on the face of it and against the stub or counterfoil that it is issued in lieu of a share certificate or is a duplicate issued for the one so replaced and, in the case certificate issued in place of one which has been lost or destroyed the word 'duplicate' shall be stamped or punched in bold letters across the face thereof. Every certificate under this Article shall be issued on payment of fees for each certificate as may be fixed by the Board.

The particulars of every such share certificate shall be entered in the Register of Renewed and Duplicate Certificates maintained in the form and manner specified under the Companies Act.

Provided that, notwithstanding what is stated above, the Board shall comply with such rules or regulation or requirements of any stock exchange or the rules made under the Companies Act or the rules made under Securities Contracts (Regulation) Act, 1956 or any other act, or rules applicable in this behalf. The provisions of this Article shall mutatis mutandis apply to debentures of the Company.

No fee shall be charged for sub-division and consolidation of share / debenture certificates and for sub-division of letters of allotment, split and consolidation. Renewal and pucca transfer receipts into denominations corresponding to the market units of trading, for sub-division of renounceable letters of rights.

### **Borrowing Powers**

The Board may, from time to time and at its discretion, subject to the applicable provisions of the Companies Act and directions issued by the Reserve Bank of India raise or borrow either from the Directors or from elsewhere and secure the payment of any sums or sum of money for the purposes of the Company. The Board may raise or secure the repayment of such sum or sums in such manner and upon such terms and conditions in all respects as it thinks fit.

### **Issue of Bonus Shares**

The Company in its general meeting may resolve to issue the bonus shares to its shareholders subject to the applicable provisions of the Companies Act and other laws as may be applicable in this behalf from time to time.

### **General Meetings**

All general meetings of the Company other than the Annual General Meeting shall be called an extra ordinary general meeting.

### **Meetings of Directors**

The Directors may meet together for the dispatch of business, adjourn and regulate their meetings and proceedings as they think fit provided that meetings of the Board are held at least four times every year in such a manner that not more than 120 (One Hundred and Twenty) days shall intervene between two consecutive meetings of the Board. Notice in writing of every meeting to the Directors shall ordinarily be given by a Director or Company Secretary or such other officer of the Company duly authorized in this behalf to every Director for the time being in India in accordance with the provisions of the Companies Act.

The quorum for a meeting of the board shall be one-third of its total strength or two Directors, whichever is higher, subject to the Companies Act. If a quorum is not present within half an hour of the time appointed for the meeting or ceases to be present, the Director(s) present shall adjourn the meeting to a specified date, time and place as specified in the Companies Act or at such date, place and time as may be decided by the Chairman.

Subject to the provisions of the Companies Act, the control of the Company shall be vested in the Board who shall be entitled to exercise all such powers and to do all such acts and things as may be exercised or done by the Company and are not hereby or by law expressly required or directed to be exercised or done by the Company in the general meeting but subject nevertheless to provisions of any law and of these presents, from time to time, made by the Company in general meeting, provided that no regulation so made shall invalidate any prior act of the Directors which would have been valid if such regulation had not been made.

### **Managing Directors**

Subject to the provision of the Companies Act, the Board may, from time to time, appoint one or more Directors to be managing director or managing directors of the Company and may, from time to time, (subject to the provisions of any contract between him or them and the Company), remove or dismiss him or them from office and appoint another or others in his place or their places.

### **Extra-ordinary general meeting**

The Board may, whenever they think fit, call an extra ordinary general meeting in accordance with the Companies Act.

### **Votes of Members**

On a show of hands every member present in person and being a holder of equity shares shall have one vote and every person present either as a Proxy on behalf of a holder of equity shares or as a duly authorized representative of a body corporate being a holder of equity shares, if he is not entitled to vote in his own right, shall have one vote.

On a poll, the voting rights of holder of equity shares shall be in proportion to his share in the paid-up equity share capital of the Company. A member may exercise his vote at a meeting by electronic means in accordance with the Companies Act and shall vote only once.

No Company or body corporate shall vote by Proxy so long as a resolution of the Board under Section 113 of the Companies Act is in force and the representative named in such resolution is present at the general meeting at which the vote by Proxy is tendered.

A person becoming entitled to a share shall not before being registered as member in respect of the share be entitled to exercise in respect thereof any right conferred by membership in relation to meeting of the Company.

No member shall be entitled to exercise any voting rights either personally or by Proxy at any meeting of the Company in respect of any shares registered in his name on which any calls or other sums presently payable by him have not been paid or in regard to which the Company has exercised any right or lien.

### **Dividend**

The Company in general meeting may declare the dividend to be paid to the members according to their rights and interest in the profits and may, subject to the provisions of the applicable law, fix the time for payment.

Subject to rights of members entitled to shares (if any) with preferential or special rights attached to them, the profits of the Company, from time to time, determined to be distributed as dividend in respect of any year or other period shall be applied for payment of dividend on the shares in proportion to the amount of capital paid on the shares provided that unless the Board otherwise determines all dividends shall be apportioned and paid proportionately to the amounts paid or credited as paid up on the shares during any portion or portions of the period in respect of which dividend is paid.

No dividend shall be payable except out of the profits of the Company of the year or any other undistributed profits and no dividend shall carry interest as against the Company.

The Board may, from time to time, pay to the members such interim dividends as in their judgment the position of the Company justifies.

### **Unpaid or Unclaimed Dividend**

Any dividend remaining unpaid or unclaimed after having been declared shall be dealt in accordance with the provisions of the applicable law.

Where the Company has declared a dividend but which has not been paid or claimed within 30 (Thirty) days from the date of declaration to any shareholder entitled to the payment of the dividend, the Company within 7 (Seven) days from the date of expiry of the said period of 30 (Thirty) days, open a special account in that behalf in any scheduled bank and transfer to the said special account, the total amount of the dividend which remains unpaid or in relation to which no dividend warrant has been posted.

Any money transferred to the said special account of the Company which remains unpaid or unclaimed for a period of 7 (Seven) years from the date of such transfer, shall be transferred by the Company to the Fund known as "Investor Education and Protection Fund" established under the Companies Act and the Company shall comply with all other requirements as specified in the Companies Act or other applicable laws in respect of such unpaid or unclaimed dividend.

No unclaimed or unpaid dividend shall be forfeited by the Board before the claim becomes barred by law and the Company shall comply with the provisions of the applicable laws in respect of such dividend.

### **Winding Up**

Subject to the provisions of applicable law, if the Company is wound up and the assets available for distribution among the members as such are insufficient to repay the whole of the paid-up capital, such assets shall be distributed so that as nearly as may be the losses shall be borne by the members in proportion to the capital paid-up or which ought to have been paid-up at the commencement of the winding-up on the shares held by them respectively.

### **Indemnity**

Subject to the provisions of the Companies Act, the Company shall indemnify and defend its Directors, manager, Company Secretary and other officers or employees of the Company and it shall be the duty of the Company to pay out of the fund of the Company all bonafide costs losses and expenses, (including traveling expenses) which any such Director, manager or Secretary or other officer or employee may incur or become liable to by reason of any contract entered into or any way in the discharge of his or their duties and in particular, and so as not to limit the generality of the foregoing provisions, against all bonafide liabilities incurred by him or by them as such Director, manager, Secretary, officer or employee in any proceeding whether civil or criminal in which judgment is given in his or their favour or he or they is or are acquitted, or in connection with any application under Section 463 of the Companies Act in which relief is granted by the court or tribunal and the amount for which such indemnity is provided shall immediately attach as a lien on the property of the Company and have priority as between the members over all other claims.

## **PART II**

Part II of the Articles of Association of the Company provide for the rights and obligations of the parties to the Shareholders Agreement dated September 25, 2007, as amended ("SHA"), entered into between the Investors, Sponsors and the Company. Until commencement of listing and trading of the equity shares of the Company on BSE Limited and/or

National Stock Exchange of India Limited, in case of any inconsistency between Part I and Part II of the Articles, the provisions of Part II shall prevail over Part I.

Part II of the Articles of Association shall terminate and shall be deemed to fall away without any further action immediately on the commencement of listing and trading of the equity shares of the Company on BSE Limited and/or National Stock Exchange of India Limited in accordance with applicable laws.

If the Equity Shares do not get listed and commence trading on BSE Limited and/or the National Stock Exchange of India Limited by September 30, 2019, or any such extended date as may be mutually agreed between the parties to the SHA, the Company and Sponsors of the Company shall take all steps to amend the Articles of Association of the Company in the manner acceptable, and to the satisfaction of the Investors.

## SECTION IX: OTHER INFORMATION

### MATERIAL CONTRACTS AND DOCUMENTS FOR INSPECTION

The copies of the following documents and contracts which have been entered or are to be entered into by our Company (not being contracts entered into in the ordinary course of business carried on by our Company or contracts entered into more than two years before the date of this Draft Red Herring Prospectus) which are or may be deemed material will be attached to the copy of the Red Herring Prospectus which will be delivered to the RoC for registration. Copies of the above mentioned contracts and also the documents for inspection referred to hereunder, may be inspected at the Registered Office between 10 a.m. and 5 p.m. on all Working Days from the date of the Red Herring Prospectus until the Bid/Offer Closing Date.

Any of the contracts or documents mentioned in this Draft Red Herring Prospectus may be amended or modified at any time if so required in the interest of our Company or if required by the other parties, without reference to the Shareholders, subject to compliance of the provisions contained in the Companies Act and other applicable law.

#### A. Material Contracts for the Offer

1. Registrar Agreement dated December 3, 2018 entered into between our Company, the Selling Shareholders and the Registrar to the Offer.
2. Offer Agreement dated December 5, 2018 entered into between our Company, the Selling Shareholders and the BRLMs.
3. Cash Escrow Agreement dated [●] entered into between our Company, the Selling Shareholders, the Registrar to the Offer, the BRLMs and the Banker(s) to the Offer.
4. Share Escrow Agreement dated [●] entered into between the Selling Shareholders, our Company and the Share Escrow Agent.
5. Syndicate Agreement dated [●] entered into between our Company, the Selling Shareholders, the BRLMs, the Syndicate Members and the Registrar to the Offer.
6. Underwriting Agreement to be entered into between our Company, the Selling Shareholders, and the Underwriters.

#### B. Material Documents

1. Certified copies of the Memorandum of Association and Articles of Association of our Company as amended from time to time.
2. Certificate of incorporation dated September 26, 1994.
3. Certificate of commencement of business dated September 7, 1998.
4. Board resolution dated June 15, 2017 and Shareholders' resolution dated September 22, 2017 for appointment of Gurdeep Soni as the Chairman and Managing Director of our Company.
5. Employment agreement dated April 1, 2016, entered into between our Subsidiary, GFPL and our Chairman and Managing Director, Gurdeep Soni and further amended on August 24, 2016, March 28, 2017 and November 10, 2018.
6. Board resolution of our Subsidiary, GFPL dated March 23, 2018 for approval of remuneration of Gurdeep Soni, our Chairman and Managing Director.
7. Employment agreement dated August 27, 2014, entered into between our Subsidiary, UUL and our Executive Director, Paramjit Singh Soni and further amended on May 30, 2016.
8. Employment agreement dated January 1, 2012, entered into between our Subsidiary, UIG and our Executive Director, Herbert Coenen and further amended pursuant to letters from UIG dated April 1, 2014 and November 20, 2015.
9. Investment Agreement dated September 13, 2007, entered into by and amongst our Promoters, Ambadevi, Ashoka and our Company.

10. Shareholders' Agreement dated September 25, 2007, entered into by and amongst our Promoters, Ambadevi, Ashoka and our Company as amended by agreements dated September 7, 2010 and February 18, 2013.
11. Deed of accession dated May 31, 2012 by which Karan Soni became a party to the Shareholders' Agreement dated September 25, 2007.
12. Deeds of accession each dated July 4, 2012 by which Meher Soni became a party to the Shareholders' Agreement dated September 25, 2007.
13. Supplemental deed dated January 30, 2014 to the Shareholders' Agreement dated September 25, 2007 entered into by and amongst our Promoters, Ambadevi, Ashoka, Karan Soni, Meher Soni and our Company.
14. Amendment and Termination Agreement dated December 3, 2018 to the Shareholders' Agreement dated September 25, 2007 entered into by and amongst our Promoters, Ambadevi, Ashoka, Karan Soni, Meher Soni and our Company.
15. Shareholders' Agreement dated May 25, 2007, entered into by and amongst our Promoters, Olsen Investors and our Company.
16. Copy of ESOP 2007.
17. Resolution of the Board dated November 23, 2018 in relation to the Offer and other related matters.
18. Resolution of the Shareholders of our Company dated November 27, 2018 in relation to the Fresh Issue and other related matters.
19. Consent letter dated December 4, 2018 by Ashoka in relation to the Offer for Sale.
20. Consent letter dated December 4, 2018 by Ambadevi in relation to the Offer for Sale.
21. Consent letter dated November 30, 2018 from CRISIL Research to rely on and reproduce part or whole of the CRISIL Report and include their name in this Draft Red Herring Prospectus.
22. Consent dated November 30, 2018 from Frost & Sullivan to rely on and reproduce part or whole of the F&S Report and include their name in this Draft Red Herring Prospectus.
23. The examination report dated November 23, 2018 of the Statutory Auditor, on our Restated Financial Statements.
24. Consent letter from Rakesh Banwari & Co. dated November 28, 2018, the Statutory Auditor of our Company for inclusion of their name as experts.
25. The statement of tax benefits dated November 23, 2018 from the Statutory Auditor.
26. Industry report titled "*Global market assessment of 3PL and PMP products in Agriculture and Construction Equipments*" dated November, 2018 prepared by CRISIL Research.
27. Industry report titled "*Global Mobile Hydraulic Equipment Market, Forecast to 2023 – Renewed Investments in Infrastructure, Logistics, and Energy to Support the Recovery in the Mobile Hydraulic Equipment Sector*" dated July, 2018 prepared by Frost & Sullivan.
28. Copies of annual reports of the Company for the preceding five Fiscals.
29. Consent of the Directors, Individual Selling Shareholders, BRLMs, Syndicate Members, Indian Legal Counsel to our Company, Indian Legal Counsel to the BRLMs, Indian Legal Counsel to the Investor Selling Shareholders, lenders to our Company, Registrar to the Offer, Escrow Collection Bank(s), Bankers to our Company, Company Secretary and Compliance Officer, third party chartered engineer and architect as referred to in their specific capacities.
30. Due diligence certificate dated December 5, 2018 addressed to SEBI from the BRLMs.
31. In-principle listing approvals dated [●] and [●] issued by BSE and NSE, respectively.
32. Tripartite agreement dated December 18, 2012 among our Company, NSDL and the Registrar to the Offer.



33. Tripartite agreement dated August 25, 2014 among our Company, CDSL and the Registrar to the Offer.
34. SEBI observation letter no. [●] dated [●].

## DECLARATION

We hereby declare that all relevant provisions of the Companies Act, 2013 and the guidelines or regulations issued by the Government and the guidelines or regulations issued by the SEBI, established under Section 3 of the SEBI Act, 1992, as the case may be, have been complied with and no statement made in this Draft Red Herring Prospectus is contrary to the provisions of the Companies Act, 2013, the Securities Contracts (Regulation) Act, 1956, the Securities Contracts (Regulation) Rules, 1957, the SEBI Act 1992, or the rules made or guidelines or regulations issued thereunder, as the case may be. We further certify that all statements and disclosures made in this Draft Red Herring Prospectus are true and correct.

### SIGNED BY ALL THE DIRECTORS OF OUR COMPANY

---

**Gurdeep Soni**  
*(Chairman and Managing Director)*

---

**Paramjit Singh Soni**  
*(Executive Director)*

---

**Herbert Coenen**  
*(Executive Director)*

---

**Ashish Kumar Agarwal**  
*(Nominee Director)*

---

**Alok Nagory**  
*(Independent Director)*

---

**M. R. Umarji**  
*(Independent Director)*

---

**Sharat Krishan Mathur**  
*(Independent Director)*

---

**Shradha Suri**  
*(Independent Director)*

### SIGNED BY THE CHIEF FINANCIAL OFFICER

---

**Sanjiv Kashyap**  
*(Chief Financial Officer)*

Place: Noida

Date: December 5, 2018

## DECLARATION

The undersigned Investor Selling Shareholder hereby certifies that all statements and undertakings made or confirmed by it in this Draft Red Herring Prospectus in relation to itself as an Investor Selling Shareholder and the Equity Shares being offered by it in the Offer for Sale are true and correct. The undersigned Investor Selling Shareholder assumes no responsibility for any of the statements made by the Company, the Individual Selling Shareholders or any other person(s) in this Draft Red Herring Prospectus.

**Signed for and on behalf of Ambadevi Mauritius Holding Limited**

---

**Authorised Signatory**

Name: Fareed Soreefan

Designation: Director

Date: December 5, 2018

## DECLARATION

The undersigned Investor Selling Shareholder hereby certifies that all statements and undertakings made or confirmed by it in this Draft Red Herring Prospectus in relation to itself as an Investor Selling Shareholder and the Equity Shares being offered by it in the Offer for Sale are true and correct. The undersigned Investor Selling Shareholder assumes no responsibility for any of the statements made by the Company, the Individual Selling Shareholders or any other person(s) in this Draft Red Herring Prospectus.

**Signed for and on behalf of Ashoka Investment Holdings Limited**

---

**Authorised Signatory**

Name: Sangeeta Bissessur

Designation: Director

Date: December 5, 2018

## DECLARATION

I, the undersigned, acting as an Individual Selling Shareholder hereby certify that all statements, disclosures and undertakings made or confirmed by me in this Draft Red Herring Prospectus in relation to myself and the Equity Shares being offered by me in the Offer for Sale are true and correct.

**Signed by the Individual Selling Shareholder**

---

**Andrew Warren Code**

Place: Naples, Florida, US

Date: December 5, 2018

## DECLARATION

I, the undersigned, acting as an Individual Selling Shareholder hereby certify that all statements, disclosures and undertakings made or confirmed by me in this Draft Red Herring Prospectus in relation to myself and the Equity Shares being offered by me in the Offer for Sale are true and correct.

**Signed by the Individual Selling Shareholder**

---

**Bradley Lorenz Miller**

Place: Eldridge, Iowa, US

Date: December 5, 2018

## DECLARATION

I, the undersigned, acting as an Individual Selling Shareholder hereby certify that all statements, disclosures and undertakings made or confirmed by me in this Draft Red Herring Prospectus in relation to myself and the Equity Shares being offered by me in the Offer for Sale are true and correct.

**Signed by the Individual Selling Shareholder**

---

**Craig A Johnson**

Place: Milan, Illinois, US

Date: December 5, 2018

## DECLARATION

I, the undersigned, acting as an Individual Selling Shareholder hereby certify that all statements, disclosures and undertakings made or confirmed by me in this Draft Red Herring Prospectus in relation to myself and the Equity Shares being offered by me in the Offer for Sale are true and correct.

**Signed by the Individual Selling Shareholder**

---

**Dennis Francis DeDecker**

Place: Moline, IL USA

Date: December 5, 2018



## DECLARATION

I, the undersigned, acting as an Individual Selling Shareholder hereby certify that all statements, disclosures and undertakings made or confirmed by me in this Draft Red Herring Prospectus in relation to myself and the Equity Shares being offered by me in the Offer for Sale are true and correct.

**Signed by the Individual Selling Shareholder**

---

**Diana Lynn Craig**

Place: Eldridge, Iowa, US

Date: December 5, 2018

## DECLARATION

I, the undersigned, acting as an Individual Selling Shareholder hereby certify that all statements, disclosures and undertakings made or confirmed by me in this Draft Red Herring Prospectus in relation to myself and the Equity Shares being offered by me in the Offer for Sale are true and correct.

**Signed by the Individual Selling Shareholder**

---

**James Norman Hallene**

Place: Hinsdale, Illinois USA

Date: December 5, 2018

## DECLARATION

I, the undersigned, acting as an Individual Selling Shareholder hereby certify that all statements, disclosures and undertakings made or confirmed by me in this Draft Red Herring Prospectus in relation to myself and the Equity Shares being offered by me in the Offer for Sale are true and correct.

**Signed by the Individual Selling Shareholder**

---

**Kevin John Code**

Place: Eldridge, Iowa, US

Date: December 5, 2018

## DECLARATION

I, the undersigned, acting as an Individual Selling Shareholder hereby certify that all statements, disclosures and undertakings made or confirmed by me in this Draft Red Herring Prospectus in relation to myself and the Equity Shares being offered by me in the Offer for Sale are true and correct.

**Signed by the Individual Selling Shareholder**

---

**Marc Christopher Dorau**

Place: Eldridge, Iowa, US

Date: December 5, 2018

## DECLARATION

I, the undersigned, acting as an Individual Selling Shareholder hereby certify that all statements, disclosures and undertakings made or confirmed by me in this Draft Red Herring Prospectus in relation to myself and the Equity Shares being offered by me in the Offer for Sale are true and correct.

**Signed by the Individual Selling Shareholder**

---

**Mark Louis Dawson**

Place: Eldridge, Iowa, US

Date: December 5, 2018

## DECLARATION

I, the undersigned, acting as an Individual Selling Shareholder hereby certify that all statements, disclosures and undertakings made or confirmed by me in this Draft Red Herring Prospectus in relation to myself and the Equity Shares being offered by me in the Offer for Sale are true and correct.

**Signed by the Individual Selling Shareholder**

---

**Mary Louise Arp**

Place: Eldridge, Iowa, US

Date: December 5, 2018

## DECLARATION

I, the undersigned, acting as an Individual Selling Shareholder hereby certify that all statements, disclosures and undertakings made or confirmed by me in this Draft Red Herring Prospectus in relation to myself and the Equity Shares being offered by me in the Offer for Sale are true and correct.

**Signed by the Individual Selling Shareholder**

---

**Meher Soni**

Place: Georgia, US

Date: December 5, 2018

## DECLARATION

I, the undersigned, acting as an Individual Selling Shareholder hereby certify that all statements, disclosures and undertakings made or confirmed by me in this Draft Red Herring Prospectus in relation to myself and the Equity Shares being offered by me in the Offer for Sale are true and correct.

**Signed by the Individual Selling Shareholder**

---

**Melvin Keith Gibbs**

Place: Eldridge, Iowa, US

Date: December 5, 2018



## DECLARATION

I, the undersigned, acting as an Individual Selling Shareholder hereby certify that all statements, disclosures and undertakings made or confirmed by me in this Draft Red Herring Prospectus in relation to myself and the Equity Shares being offered by me in the Offer for Sale are true and correct.

**Signed by the Individual Selling Shareholder**

---

**Misty Marie Garcia**

Place: Eldridge, Iowa, US

Date: December 5, 2018

## DECLARATION

I, the undersigned, acting as an Individual Selling Shareholder hereby certify that all statements, disclosures and undertakings made or confirmed by me in this Draft Red Herring Prospectus in relation to myself and the Equity Shares being offered by me in the Offer for Sale are true and correct.

**Signed by the Individual Selling Shareholder**

---

**Pamela Soni**

Place: New Delhi

Date: December 5, 2018

## DECLARATION

I, the undersigned, acting as an Individual Selling Shareholder hereby certify that all statements, disclosures and undertakings made or confirmed by me in this Draft Red Herring Prospectus in relation to myself and the Equity Shares being offered by me in the Offer for Sale are true and correct.

**Signed by the Individual Selling Shareholder**

---

**Walter James Gruber**

Place: Eldridge, Iowa, US

Date: December 5, 2018

## DECLARATION

I, the undersigned, acting as an Individual Selling Shareholder hereby certify that all statements, disclosures and undertakings made or confirmed by me in this Draft Red Herring Prospectus in relation to myself and the Equity Shares being offered by me in the Offer for Sale are true and correct.

**Signed by the Individual Selling Shareholder**

---

**Wendy Reichard Hammen**

Place: Eldridge, Iowa, US

Date: December 5, 2018